



Expertise Applied | Answers Delivered

AEC-Q200 Specification for Automotive Applications



Automotive

Users must independently evaluate the suitability of and test each product selected for their own specific applications. It is the User's sole responsibility to determine fitness for a particular system or use based on their own performance criteria, conditions, specific application, compatibility with other parts, and environmental conditions. Users must independently provide appropriate design and operating safeguards to minimize any risks associated with their applications and products. Littelfuse products are not designed for, and may not be used in, all applications. Read complete Disclaimer Notice at littelfuse.com/disclaimer-electronics.

Littelfuse has a long history of defining safety needs and developing components for automobiles

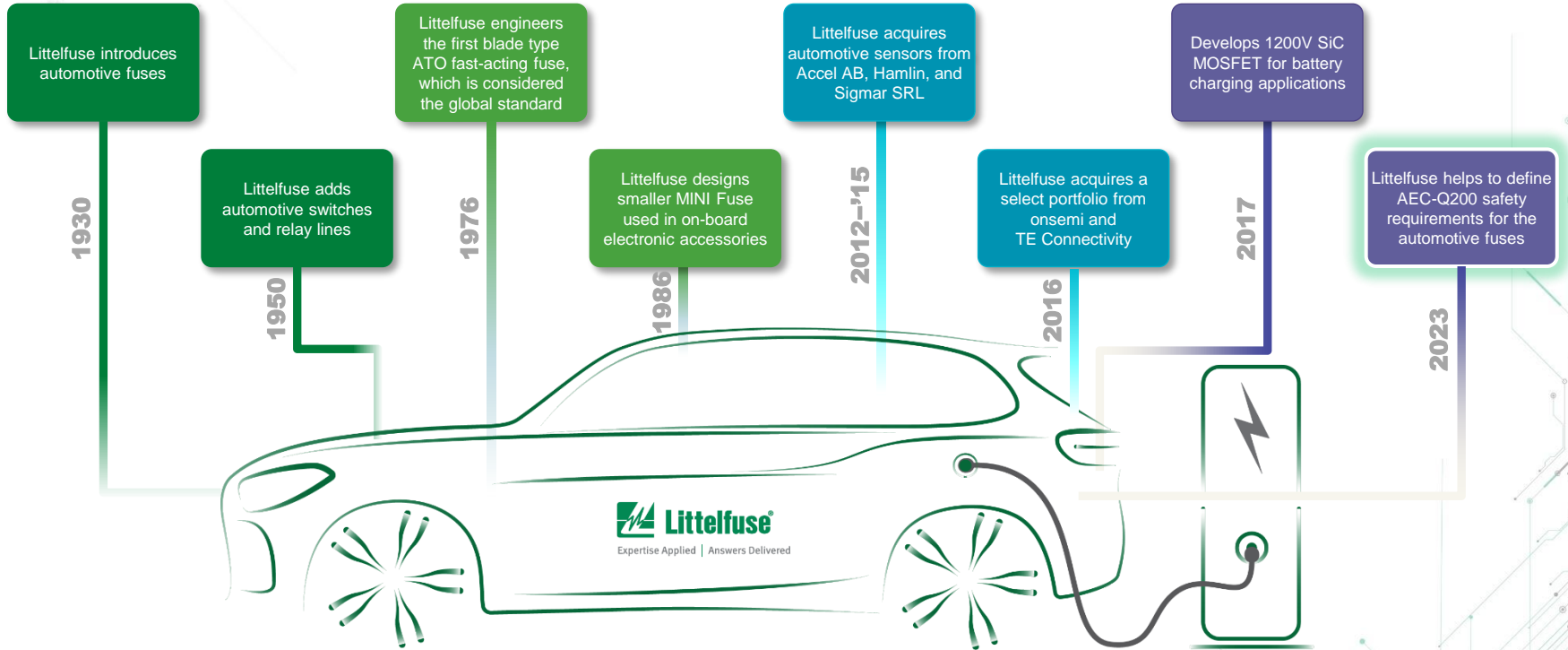

Littelfuse has contributed to the development of the **AEC-Q200 Rev E Standard** released in March 2023

Advanced electronics are driving innovation in multiple automotive applications

Infotainment & communication

- Smart infotainment
- Navigation
- Multipurpose camera
- Telematics box



Network systems & body electronics

- CAN, LIN
- USB, Wireless
- Keyless entry
- Lighting control



Advanced Driver Assistance System

- V2X Communication
- Radar
- eCall
- Sensor fusion



Power train

- Battery management system
- On-board charger
- Traction motor inverter
- DC-DC converter

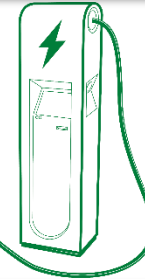

Chassis and safety system

- Seatbelt safety
- Tire pressure monitoring
- Battery disconnect
- Fuel level detection

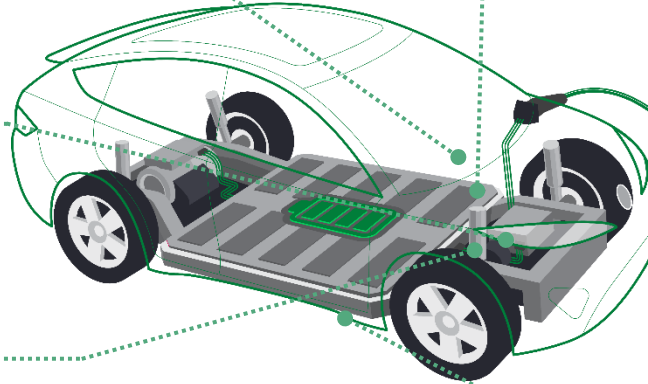

We satisfy the need for reliable, high-quality circuit protection products for safety and reliability



Expertise Applied | Answers Delivered

Introduction to Automotive Electronics Council (AEC)

Body for establishing standards for reliable, high quality electronic components

Key highlights

The Automotive Electronics Council (AEC) was originally established in the 1990s by Chrysler, Ford, and GM to establish common part-qualification and quality-system standards.

From its inception, the AEC has consisted of two committees: the Quality Systems Committee and the Component Technical Committee.

Components meeting the specifications listed by the Component Technical Committee are suitable for harsh automotive environments.

Different AEC-Q Standards:

- **AEC-Q100**–Failure Mechanism-Based Stress Test Qualification for Integrated Circuits
- **AEC-Q101**–Failure Mechanism-Based Stress Test Qualification for Discrete Semiconductors
- **AEC - Q102**–Failure Mechanism-Based Stress Test Qualification for Discrete Optoelectronic Semiconductors in Automotive Applications
- **AEC - Q103**–Failure Mechanism-Based Stress Test Qualification for Sensors in Automotive Applications
- **AEC - Q104**–Failure Mechanism-Based Stress Test Qualification for Multichip Modules (MCM) In Automotive Applications
- **AEC-Q200–Stress Test Qualification for Passive Components**

Proliferation of electronics in today's vehicles

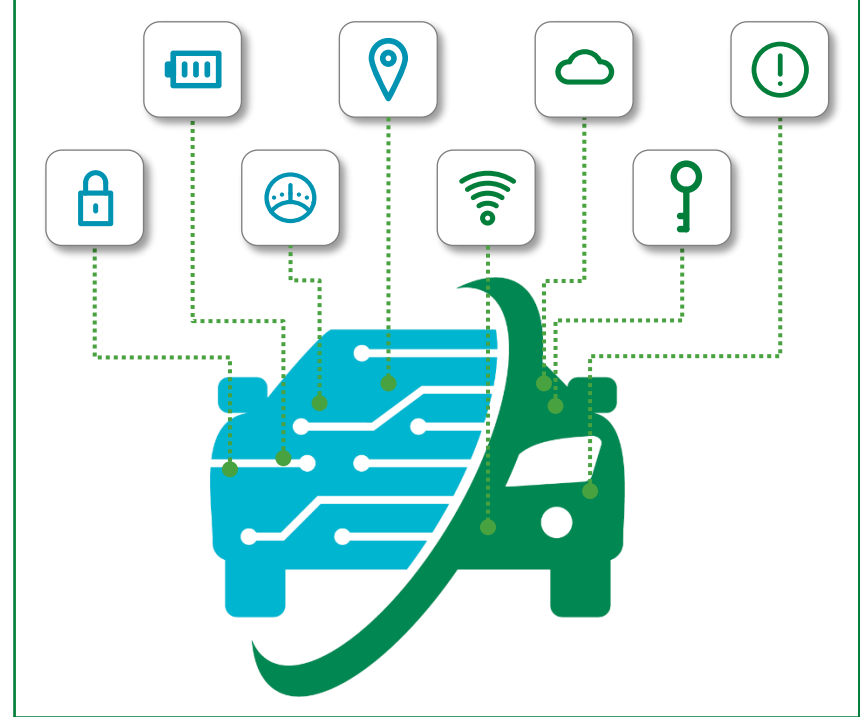

AEC-Q200 Rev D: Stress test qualification for passives

Resistor, capacitor, inductor, transformer, resonator, crystal, PTC, NTC, thermistor, and varistor

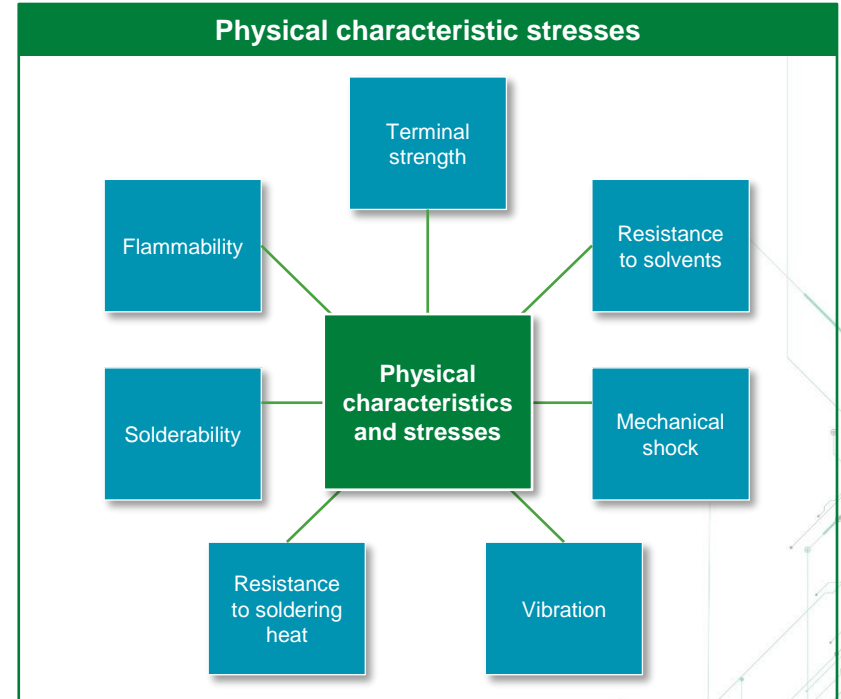
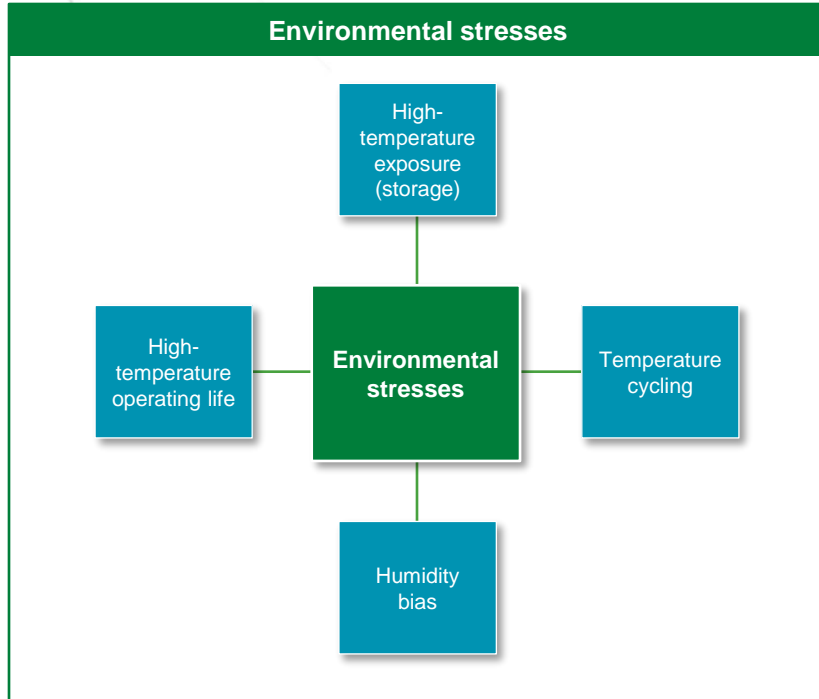

Two main tests: Environment stresses and physical characteristics stresses

New [AEC-Q200 Rev E](#) (released on March 20, 2023) adds reliability qualifications for fuses

Key highlights

The AEC-Q200 Rev E expands its scope to provide a single standard that manufacturers can use to design and test fuses for the automotive market.

Fuses provide necessary overcurrent protection for all the circuits in a vehicle, and fuses should meet the rigorous standards for use in automotive equipment that other passive components must meet.

Littelfuse has contributed to the development of Revision E and the framework for defining the test requirements for fuses.

Design engineers developing systems for automotive vehicles will be able to select AEC-Q200 Qualified fuses that have been subjected to an extensive set of tests to ensure a rugged and reliable product.

AEC-Q200 E qualification fuse stress tests

Stress	No.	Reference
Pre- and post-stress electrical test	1	UL 248, IEC 60127, or User Specification
High-temperature exposure (storage)	3	MIL-STD-202, Method 108
Temperature cycling	4	JESD22-A104
Humidity bias	7	MIL-STD-202, Method 103
High-temperature operating life	8	MIL-STD-202, Method 108
External visual	9	MIL-STD-883, Method 2009
Physical dimensions	10	JESD22-B100
Terminal strength (for axial and radial THT components)	11	MIL-STD-202, Method 211
Resistance to solvents	12	MIL-STD-202, Method 215
Mechanical shock	13	MIL-STD-202, Method 213
Vibration	14	MIL-STD-202, Method 204
Resistance to soldering heat	15	MIL-STD-202, Method 210
Solderability	18	J-STD-002
Electrical characterization	19	UL 248, IEC 60127, or User Specification
Flammability	20	UL 94 or IEC 60695-11-5
Board Flex (SMD)	21	AEC-Q200-005
Terminal strength (SMD)	22	AEC-Q200-006

AEC-Q200 Methodology

General



Fuses

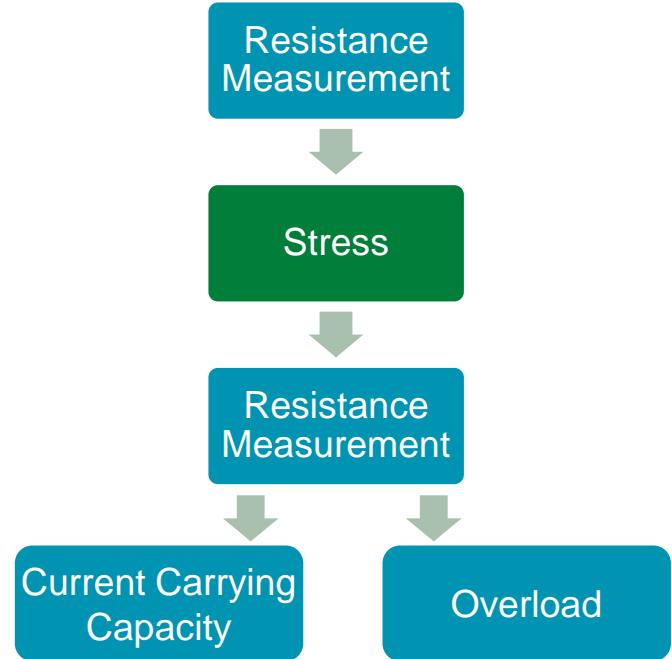

AEC-Q200 test plan vs. typical validation test plan

AEC-Q200

TYPICAL

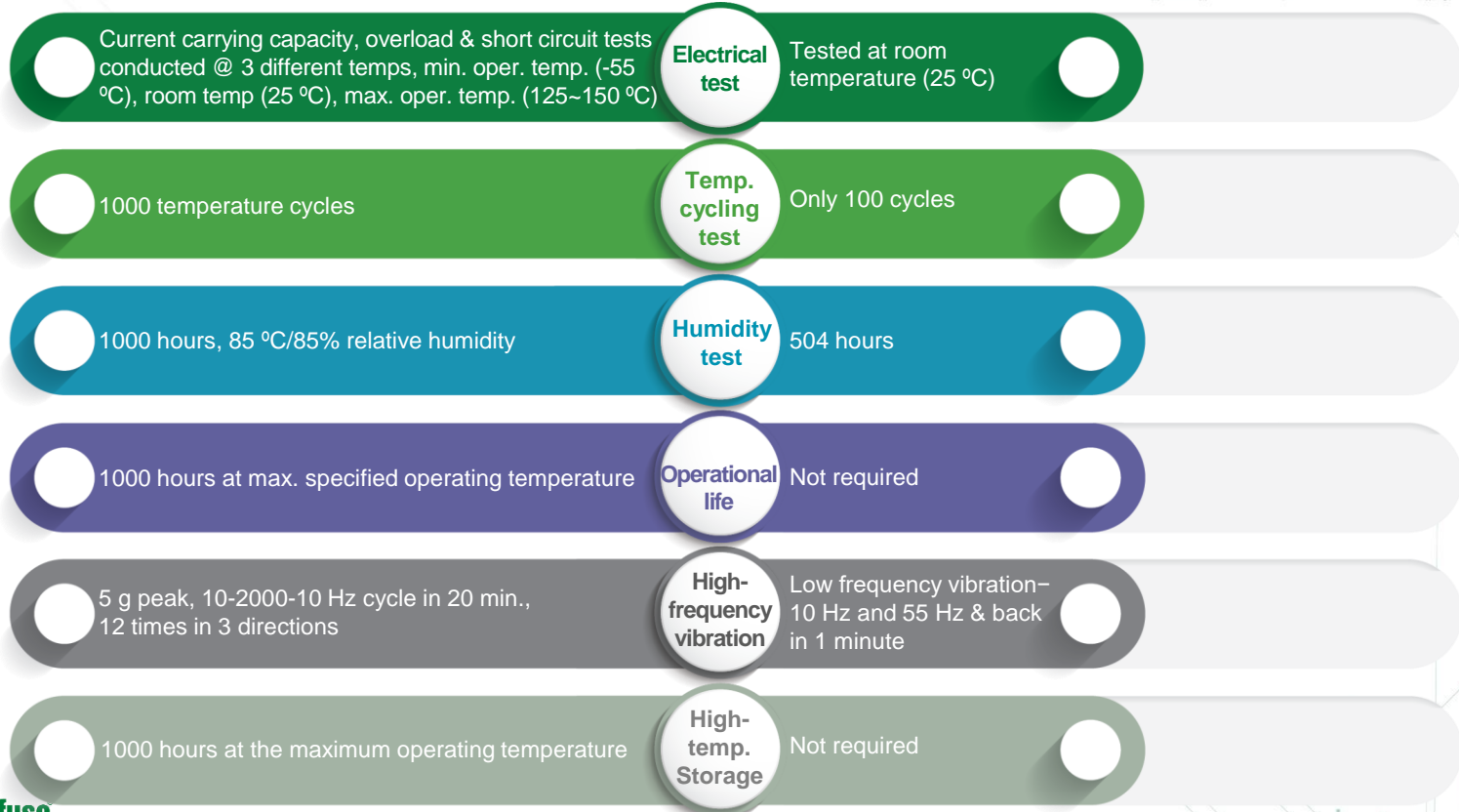

Littelfuse internal qualification tests were already aligned with the AEC-Q200 Rev. E

Internal test results in the datasheet

Materials	Body: Glass-Reinforced Epoxy Terminations: Cu/Ni/Sn (100% Pb-free)
Moisture sensitivity level	IPC/JEDEC J-STD-020, Level 1
Thermal shock	JESD22-A104C
Biased humidity	MIL-STD-202, Method 103, Test Condition D w/ exemptions
High temperature storage	MIL-STD-202, Method 108, Test Condition D w/ exemptions
High temperature operational life	MIL-STD-202, Method 108, Test Condition D
Mechanical shock	MIL-STD-202, Method 213
High frequency vibration	MIL-STD-202, Method 204
Resistance to solvents	MIL-STD-202, Method 215
Resistance to soldering heat	MIL-STD-202, Method 210
Salt fog	MIL-STD-202, Method 101
Moisture resistance	MIL-STD-202, Method 106
Terminal strength	AEC-Q200-006
Board flex	AEC-Q200-005
Solderability	JESD22-B102E Method 1
Pulse testing	Device specification
Electrical characterization	Conducted at minimum, ambient, and maximum temperatures

483A Series Datasheet

Product Characteristics

Materials	Body: Glass-Reinforced Epoxy Terminations: Cu/Ni/Sn (100% Pb-free)
Moisture Sensitivity Level	IPC/JEDEC J-STD-020, Level 1
Thermal Shock	JESD22-A104C
Biased Humidity	MIL-STD-202, Method 103, Test Condition D w/ exemptions
High Temperature Storage	MIL-STD-202, Method 108 Test Condition D w/ exemptions
High Temperature Operational Life	MIL-STD-202, Method 108, Test Condition D
Mechanical Shock	MIL-STD-202, Method 213
High Frequency Vibration	MIL-STD-202, Method 204
Resistance to Solvents	MIL-STD-202, Method 215
Resistance to Soldering Heat	MIL-STD-202, Method 210
Salt Fog	MIL-STD-202, Method 101
Moisture Resistance	MIL-STD-202, Method 106
Terminal Strength	AEC-Q200-006
Board Flex	AEC-Q200-005
Solderability	JESD22-B102E Method 1
Pulse Testing	Device Specification
Electrical Characterization	Conducted at minimum, ambient, and maximum temperatures



Littelfuse is one of the first suppliers of AEC-Q200 Qualified fuses

Littelfuse invents the FIRST automotive fuse in 1930



Contributed to the development of Revision E



Member of the AEC Technical Committee



Internal qualification aligned with the new AEC-Q200 requirement



First to market with AEC-Q200 Qualified fuses



Wide array of AEC-Q100, AEC-Q101, and AEC-Q200 components to choose from



Global manufacturing facilities certified ISO 9001, ISO 14001, and IATF 16949



Application expertise



Littelfuse AEC-Q200 Qualified fuse portfolio

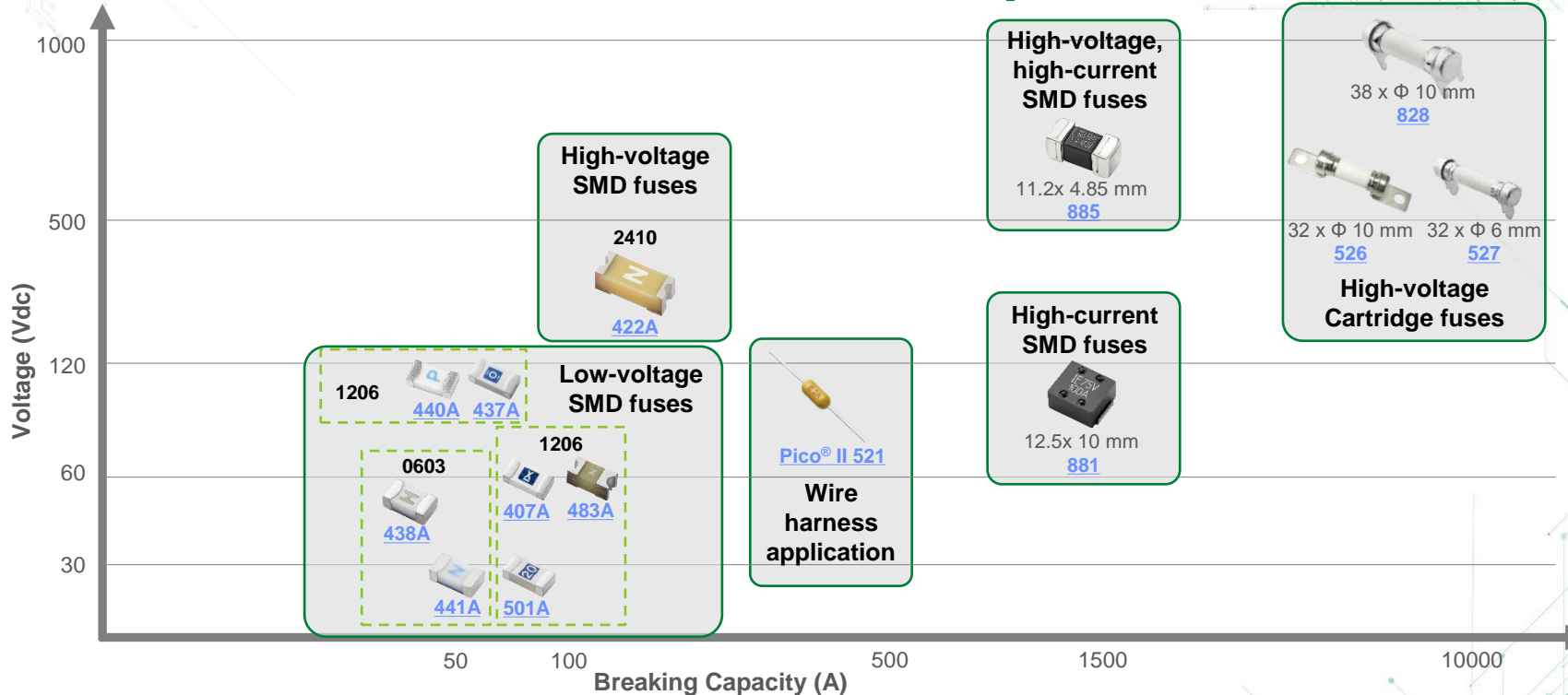

To learn more about Littelfuse's AEC-Q200 Qualified fuses portfolio, click [here](#)

AEC-Q200 Qualified fuses in automotive applications

SMD fuses for 12–48 V applications



100 V SMD fuse used in BMS



Inline fuse for wire harness used in centralized BMS



500 V, SMD or cartridge fuses for BMS, OBC, & PDU



1000 V cartridge fuses for OBC & PDU

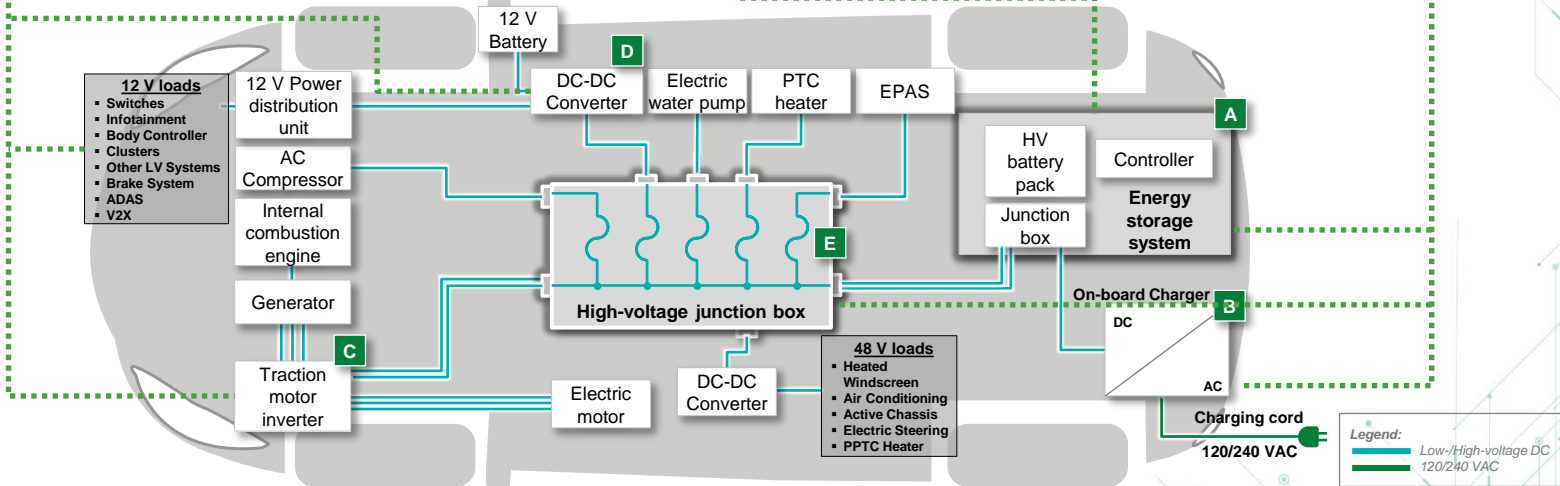



Expertise Applied | Answers Delivered

AEC-Q200 vs. ISO 8820

AEC-Q200 vs. ISO 8820 test methodology

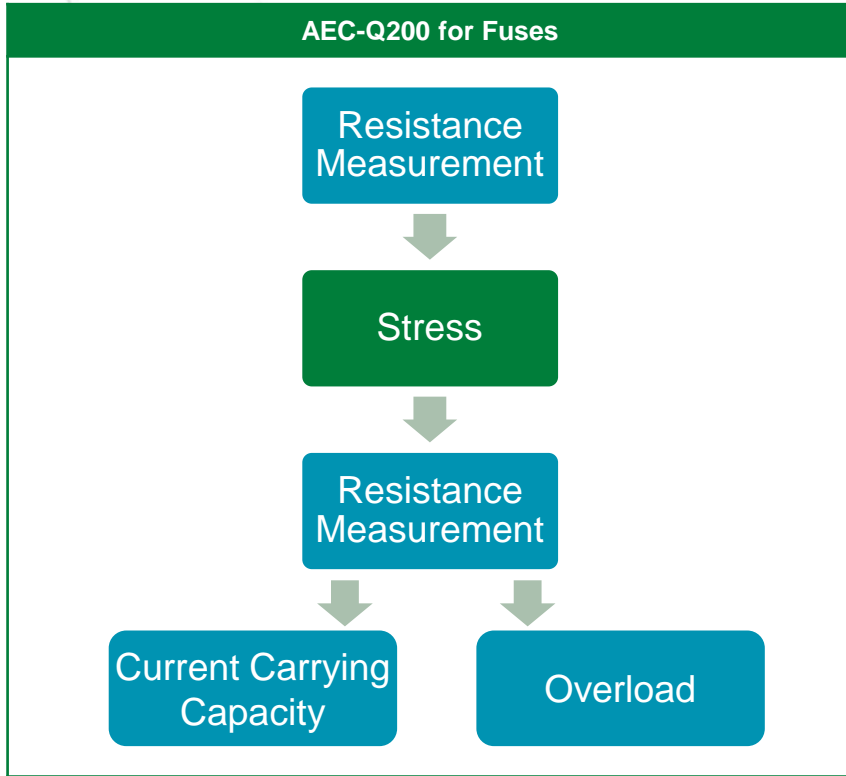

AEC-Q200 vs. ISO 8820 test requirements

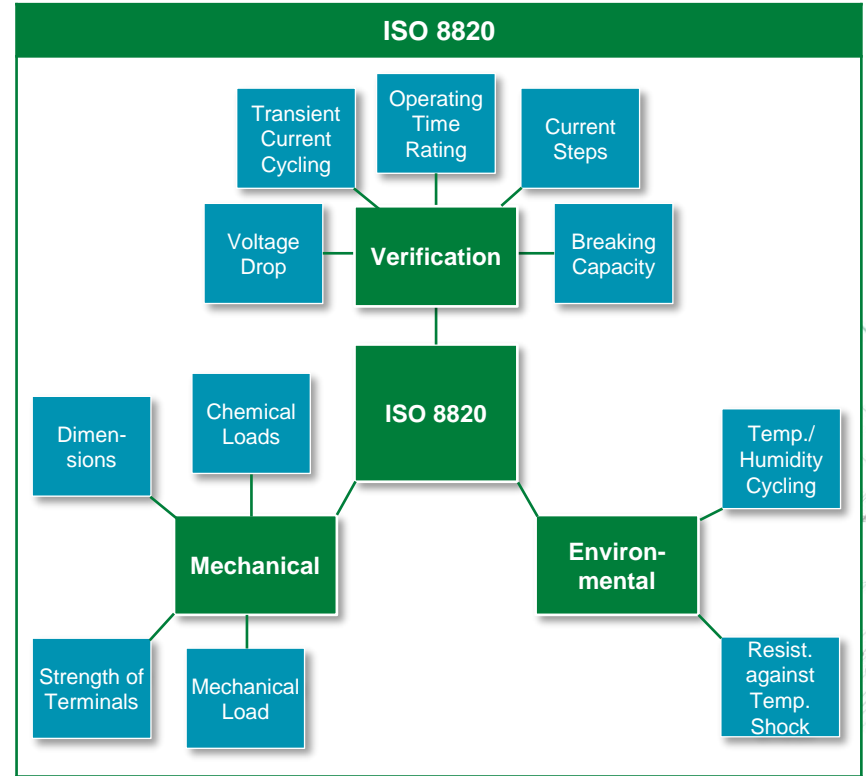
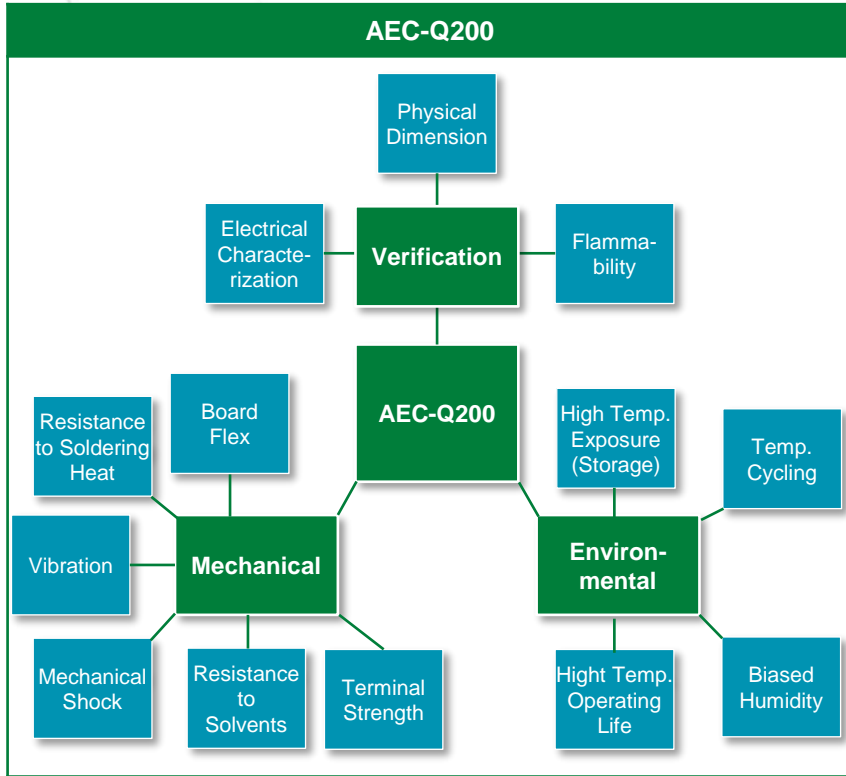

AEC-Q200 test requirements

Verification

Electrical Characterization

- Min. Ambient Temp.
- Room Ambient Temp.
- Max. Ambient Temp.
- AEC requires 30 samples vs. LF requires 30 samples from 3 lots

Physical Dimension

- 30 Samples
- Verify physical dimensions meet applicable component specification
- Pre/post not required

Flammability

- Verify material is V-1, V-0 or 5VA
- If not V-1, V-0 or 5VA, conduct Needle Flame Test per IEC 60695-11-5
- Pre/post not required

Mechanical

Terminal Strength (THT)

- For leaded (THT) fuses only
- Test Condition A for Pull-test
 - 5 pounds force axis of term. (5-10 secs)
- Test Condition C for wire-lead bend test
 - 3 cycles of 1 or ½ pound force

Terminal Strength (SMD)

- SMD only
- Force increased to 17.7N
- Duration 60 sec

Resistance to Solvents (4 Solvents)

- By vol., 1 part IUPAC to 3 parts mineral spirits
- EC-7R (Bioact)
- By vol., 42:1:1 of H₂O, PGME, MEA
- IUPAC

Mechanical Shock

- THT and SMD: Condition C (100g peak value, 6 msec duration, Half-sine waveform, 12.3 ft/sec velocity, 6 shocks pulses in 3 planes)

Vibration

- 5g peak
- 20 minutes
- 10 Hz to 2,000 Hz
- 12 cycles in each 3 directions
- Mounted per specification

Resistance to Soldering Heat

- THT:** Cond. B: Solder dip (tinning), Cond. C & D: Wave solder (top/bottom side), 260°C, 20s dwell time, 1 cycle
- SMD:** Cond. K: Infrared/convection reflow, 260°C, 30s dwell time, 3 cycles

Board Flex (SMD)

- SMD only
- Force enough for 2 mm board bend distance
- Duration 60 sec

Environmental

High Temp. Exposure (Storage)

- Unpowered
- Chamber Temperature: max ambient temp. or max storage temp. (whichever is higher)
- Duration: 1,000 hrs

Temp. Cycling

- Unpowered
- Number of Cycles: 1,000
- Lower Chamber Temp.: min ambient temp.
- Upper Chamber Temp.: max ambient temp.
- Dwell Time: 15 minutes min
- Transition Time: 1 minute max

Biased Humidity

- 10% of In
- Duration: 1,000 hrs
- 85 °C, 85% relative humidity

High Temp. Operating Life

- At re-rated In
- Duration: 1,000 hrs.
- Max operating temp.

ISO 8820 test details

Verification

Voltage Drop

- Verify energy consumptions of fuse-link which creates temp. rise
- At 23 ± 5 °C, rated current
- Record Voltage Drop (VD)—not exceed values in subsequent ISO 8820 parts

Transient Current Cycling

- Ability to withstand transient pulses
- At 23 ± 5 °C; pulse given in subsequent ISO 8820 parts; 50,000 cycles
- Meet operating time rating test

Operating Time Rating

- Ability to function during overloads
- At 23 ± 5 °C; at overloads specified in subsequent ISO 8820 parts
- Meet operating time within limits of subsequent ISO 8820 parts

Current Steps

- Ability to withstand prolonged heating due to low-level overloads
- At 23 ± 5 °C; apply fuse current till temp. stabilization; increase by 2.5% current rating till temp. stabilization
- Fuse-element melts & current is interrupted

Breaking Capacity

- Ability to withstand the breaking current
- At 23 ± 5 °C; apply fuse-link breaking capacity at rated voltage; after interruption, hold rated voltage for 30s
- No permanent arcing, no ruptures to fuse surface, fuse-link shall be removable

Mechanical

Dimensions

- Verify dimensions as required in subsequent ISO 8820 parts

Chemical Loads

- Fuse-links resistance to chemicals: (Diesel fuel, Bio-diesel fuel, Gasoline, etc.)
- Cotton cloth moistened with each fluid Wipe five times with force of 5N
- After test, marking shall remain legible, and color remain recognizable

Strength of Terminals

- Fuse-links withstand of insertion & removal
- Force value depends on fuse-link construction
- Force value found in subsequent ISO 8820 parts

Mechanical Load

- Verify fuse-links resistance to chemicals: (Diesel fuel, Bio-diesel fuel, Gasoline, etc.)
- Cotton cloth moistened with each fluid. Wipe five times with force of 5N
- After test, marking shall remain legible, and color remain recognizable

Environmental

Temperature/ Humidity Cycling

- Verify fuse-link operates under environmental stresses
- Number of cycles: 10
- Duration of a single cycle: 24 hours
- Cycle consists of:
 - 4 hours at standard conditions
 - 0.5 hour transition maximum
 - 10 hours at 55 °C/95-99%RH
 - 2.5 hour transition maximum
 - 2 hours at -40 °C
 - 1.5 hour transition maximum
 - 2 hours at 120 °C
- After cycling, fuse-link must meet operating time rating

Resistance against Temperature Shock

- Verify fuse-link operates under environmental stresses
- Number of cycles: 48
- Duration of a single cycle: 40 minutes
- Cycle consists of:
 - 20 minutes at -40 °C
 - 15 seconds maximum transition time
 - 20 minutes at 100 °C
 - 15 seconds maximum transition time
- After cycling, fuse-link must meet operating time rating



Expertise Applied | Answers Delivered

Fuse selection criteria

Fuse Selection Parameters

No.	Question	Answer
1	Normal operating current	The maximum current that the fuse will experience during normal operation of the application
2	Application voltage (AC or DC)	The voltage level of the line that the fuse is protecting; this is also the voltage that the fuse will have to safely support after it has opened
3	Ambient temperature	The temperature in the area surrounding the fuse
4	Maximum available fault current	The maximum current that the fuse will experience during normal operation of the application
5	Current Pulses <ul style="list-style-type: none">▪ Shape▪ Magnitude▪ Duration▪ Quantity of the pulses	Surge Currents, Inrush Currents, Start-up Currents, and Circuit Transients
6	Overload current	Amplitude and length of time in which the fuse must open
7	Other	<ul style="list-style-type: none">▪ Mounting requirements – Through hole, SMT, Fuse holder, Physical size limitations▪ Agency Approvals required, such as UL, CSA, VDE, METI, MITI or Military

Fuse selection process:

Summary of steps to select fuse

Understand the application and circuit parameters – V, I, Temp, Max fault, Time to damage, Size, Package, Accessories

Determine minimum current rating of fuse
(fuse re-rating, thermal de-rating)

$$I_r \text{ Min} = \frac{I_n \text{ Max}}{\text{FDR} \times \text{TDR}}$$

Determine Pulse I²t value of the application

$$\text{Pulse } I^2t = I_p^2 \times t$$

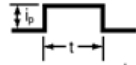

Determine minimum Nominal melting I²t value of the application

Fuse Min I²t rating = Pulse I²t / rating factor



Compare calculated and actual nominal melting I²t values to ensure fuse will not suffer nuisance opening. If there are multiple fuses qualified for the application, use secondary characteristics (size, voltage rating, etc.) to determine best solution

Check T-C curve

IMPORTANT!! Even though care may be used during the fuse selection process, it is recommended that application-level testing be performed to verify coordination of fuses to the circuit conditions





AEC-Q200 Qualified cartridge fuse portfolio

Parameter	828	526	527
Product Photo			
Footprint/Height	38 x Φ 10 mm	32 x Φ 10 mm	32 x Φ 6 mm
Voltage Rating	1000 VDC	500 VAC/VDC	500 VAC
Interrupting Rating	10 kA @ 1000 VDC	10 kA @ 500 VAC/VDC	10 kA @ 500 VAC
Amperage Rating	15 A ~ 30 A	30–60 A	30–50 A
Operating Temperature	-55 °C to +125 °C	-55 °C to +125 °C	-55 °C to 125 °C

Key highlights

- AEC-Q200 Qualified
- Rated from 500 VDC/VAC–1000 VDC with an interrupting rating of 10 kA and 15–60 A nominal current rating in a small package
- Compact body size (6 x 32 mm, 10 x 32 mm, 10 x 38 mm)

AEC-Q200 Qualified surface mount fuses

Parameter	885	881
Product Photo		
Footprint/Height	10.86 mm x 4.78 mm	12.5 mm x 10 mm
Voltage Rating	500 VDC	100 VDC
Interrupting Rating	1500 A @ 350 VDC	1500A @ 75VDC
Amperage Rating	1 A–5 A	60A ~ 125 A
Operating Temperature	-55 °C to 105 °C	-55 °C to 100 °C

Key highlights

- AEC-Q200 Qualified
- High DC voltage up to 500 VDC and interrupting current rating up to 1500 A
- Compact body size (10.86 x 4.78 mm)

AEC-Q200 Qualified surface mount thin film chip fuses

Parameter	441A	501A	407A	438A	440A	483A	437A	422A
Product photo								
Footprint/ height	0603	1206	1206	0603	1206	1206	1206	2410
Voltage rating	32 VDC	32 VDC	24–63 VDC	24–63 VDC	50–125 VDC	75 VAC/VDC	32–125 VDC	125–250 VAC/VDC
Interrupting rating at rated voltage	50 A	150 A	50 A	50 A	50 A	50 A	50 A	50–100 A
Amperage rating	2–6 A	10–20 A	1–8 A	0.25–6 A	0.25–8 A	0.75–2 A	0.25–8 A	0.75–5 A
Operating temperature	-55 °C to 150 °C	-55 °C to 150 °C	-55 °C to 150 °C	-55 °C to 150 °C	-55 °C to 150 °C	-55 °C to 125 °C	-55 °C to 150 °C	-55 °C to 125 °C

Key highlights

- AEC-Q200 Qualified
- Wide range of fuse selections (24–250 VAC/VDC) and amperage ratings (0.25–20 A)
- Compact body size (0603, 1206, and 2410)

Additional information can be found on [Littelfuse.com](https://www.littelfuse.com)

Explore the world of Littelfuse with the electronics eCatalogs (ecatalogs.littelfuse.com)

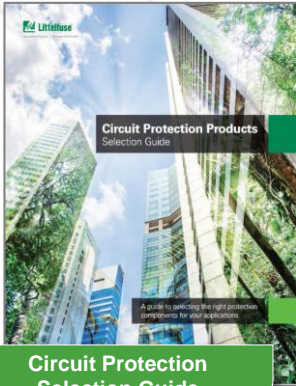

Circuit Protection Selection Guide

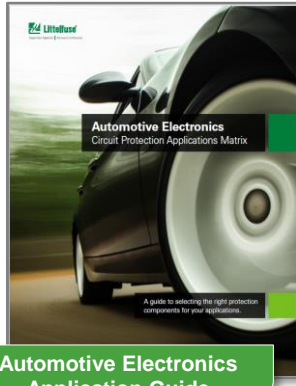

Automotive Electronics Application Guide

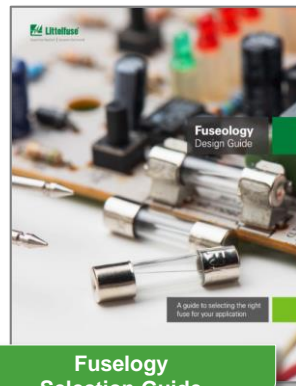

Fuseology Selection Guide



ESD Protection Selection Guide

Click on images for more information

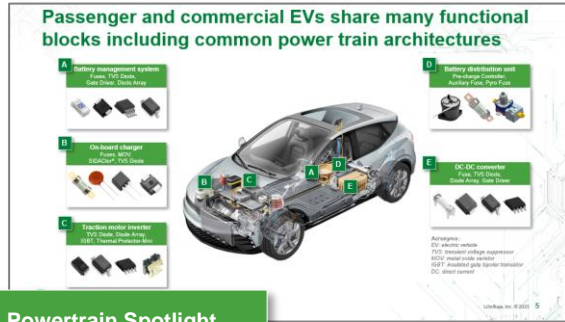

Powertrain Spotlight



Connectivity and ADAS

Local resources supporting our global customers



Legend
■ Sales
■ R&D
■ Manufacturing

Your partner for tomorrow's electronic systems

Broad product portfolio

We are an industrial technology manufacturing company empowering a sustainable, connected, and safer world

Application expertise

Our engineers partner directly with customers to help speed up product design and meet unique needs

Global customer service

Our global customer service team will work with you to anticipate your needs and ensure a seamless experience

Compliance & regulatory expertise

We help customers in the design process to account for requirements set by global regulatory authorities

Testing capabilities

We help customers get products to market faster and offer certification testing to global regulatory standards

Global manufacturing

We offer high-quality manufacturing that is committed to the highest quality standards



This document is provided by Littelfuse, Inc. ("Littelfuse") for informational and guideline purposes only. Littelfuse assumes no liability for errors or omissions in this document or for any of the information contained herein. Information is provided on an "as is" and "with all faults" basis for evaluation purposes only. Applications described are for illustrative purposes only, and Littelfuse makes no representation that such applications will be suitable for the customer's specific use without further testing or modification. Littelfuse expressly disclaims all warranties, whether express, implied, or statutory, including but not limited to the implied warranties of merchantability and fitness for a particular purpose and non-infringement. It is the customer's sole responsibility to determine suitability for a particular system or use based on their own performance criteria, conditions, specific application, compatibility with other components, and environmental conditions. Customers must independently provide an appropriate design and operating safeguards to minimize any risks associated with their applications and products. Read complete Disclaimer Notice at: www.littelfuse.com/disclaimer-electronics.



Expertise Applied | Answers Delivered

Littelfuse.com