

Powered by

# Markt & Technik

DIE UNABHÄNGIGE WOCHENZEITUNG FÜR ELEKTRONIK

- *Semiconductor Technology*
- *IT Electronics*
- *Passive & Electromechanical Components*
- *Embedded & Wireless*
- *Automotive*
- *Rutronik Excellence*



# RUTRONIKER

# Empowering wireless innovation



Fast, efficient, easy-to-implement,  
ultra-low-power wireless IoT solutions



LEARN MORE  
[nordicsemi.com](http://nordicsemi.com)



# Smart supply chains

**W**ith increasing developments in smart factory technologies, we find ourselves in an age of volatile supply chains, requiring constant market vigilance and the ability to adapt to changing conditions. Monitoring, forecasting, and AI-based planning solutions have become essential. Edge computing is also playing an increasingly decisive role in all of this. The goal is to evade the latency issues of traditional cloud solutions by enabling real-time communication through automation technology. Certain electronic components are especially critical:

- Edge devices, like computers or microcontrollers, are deployed directly in production environments to collect data from sensors, machines and plants, before processing, and transferring the data to higher-level systems.
- Sensors for the permanent monitoring of, for example, temperature, pressure, vibration, and moisture.
- Communication modules that allow edge devices to communicate with other systems. This also demands the availability of robust communication modules such as WLAN, Bluetooth, or 5G.
- Security chips are crucial, as edge devices are vulnerable to cyber attacks, making encryption and system integrity vital.

Edge computing is viewed as the key to successful implementation of Industry 4.0 and smart factory concepts. Explore this topic further in this issue through numerous specialist articles across all our sections and be guided by our Future Market markers in each article, including those on IIoT and Internet of Everything, Future Mobility, and Advanced Materials.

In this year's CEO interview with Thomas Rudel, featured from page 16, learn about the current state of the electronics market and the performance of the SME sector in particular: How is Rutronik making itself fit for the future, especially in these uncertain times? And why are the 1974 Soccer World Cup and this year's EURO 2024 soccer tournament intrinsically linked to the transformation of Rutronik? Discover answers to these questions in the interview. So much can be revealed, though: A key element is Rutronik's strategic positioning as a broadline distributor and system provider.

Being a system provider means supporting customers during their predevelopment phases as a key partner and consultant. We consolidate all these activities under the umbrella of Rutronik System Solutions. I am especially delighted to announce that this year's Rutroniker features Customer Success articles for the first time. With the RDK4 Base Board for automotive applications, we extend our gratitude to Minebea for sharing insights into their project (page 35), and to our customer Codium Electronique for providing details on how they are using real-time kinematics (RTK) with our recently launched RAB4 Adapter Board for RTK in the development of their solutions (page 73).

Our expertise in forecasting and supply chain management is another key factor that distinguishes us as a business partner. Starting on page 55, you will find insights into the current market situation, the state of the electronics supply chain, and how Rutronik, under the leadership of Patrick Krätz, Head of Supply Chain Management, is navigating these challenges.

On behalf of the entire Rutronik team, I hope you enjoy reading the fascinating features with valuable incentives and suggestions for your work!

Yours truly,

Andreas Mangler  
Director Strategic Marketing and Authorized Representative at Rutronik

## DESIGNING WITH HIGH-PERFORMANCE CONNECTIVITY

Discover our versatile range of busbar, connector and cable solutions!



*creating  
connections  
for life*



Andreas  
Mangler

Editorial	3
-----------	---

## ● SEMICONDUCTORS

Camera and display interfaces in automotive applications: For seamless connectivity	5
All-in-one sensor platform for controlling indoor air quality: Nine in one go	7
Automotive-qualified DFN package: Compact, cost-effective and powerful	9
How ProFET Wire Guard protects the electrical system and its components: Short circuit? Not a problem.	12
Top-side cooling for better heat dissipation of automotive MOSFETs: Better cooling performance in a compact design	14

## ● RUTRONIK EXCELLENCE



CEO interview: Rutronik as a trailblazer, advisor, and partner	16
--	----

Integrative view of hardware and software: Joining forces for high-performance AI applications	19
10 years Rutronik Automotive: Strong network and own reference designs	24
RDK4 is the door opener in automotive pre-development and rapid prototyping: Precise functions of electronic door handles	35
The supply chain A-Z: Everything you need to know	55
RAB4 saves time in Real-Time Kinematics testing: Tracking solutions for safety and security	73

## ● IT ELECTRONICS

Neuronal processing units from edge use to data center: Fit for the AI age	27
Linux-based operating system for the critical infrastructure use of embedded devices: Tailor-made and secure	32

## ● PASSIVE & ELECTRO-MECHANICAL COMPONENTS

Simply solving EMI and ESD requirements: Practical tool available in various formats	38
Development of a customized connector system for high currents: New development in nine months	40
Temperature sensors in SMD format for power electronics: On the way to becoming standard connection technology	44
Ethernet transformers for high-performance networks: For data transmission rates up to 10 Gbit/s	46
Electromechanical actuators expand communication options: For more sensitivity between humans and machines	48
Why polymer for capacitors: The choice for advanced electronics	50

## ● EMBEDDED & WIRELESS

Latest WLAN standard IEEE 802.11be for real-time applications: Wi-Fi 7 triumphs with 7 features	58
5G RedCap – ideal combination of low costs and improved efficiency: More than just a 4G LTE substitute	61
Precise positioning and high-speed transmission: UWB today and in the future	64
DECT NR+ – the first non-cellular 5G standard worldwide: The missing puzzle piece in IoT	68

## ● AUTOMOTIVE

Reference design for on-board charger: Focus on miniaturization	77
Reference design for micromobility with 48 V traction inverter: For the mobility of tomorrow	80
Publishing details	82
List of advertisers	82



Camera and display interfaces in automotive applications

# For seamless connectivity

*FPGA-based interface bridges play a crucial role in complex automotive applications. They offer flexibility, adaptability, and seamless interoperability, enabling consistent connectivity between various hardware interfaces, even over long distances.*

BY PENG SHI,  
CORPORATE PRODUCT MANAGER DIGITAL  
AT RUTRONIK

The proliferation of cameras and displays in modern vehicles has revolutionized the driving experience, facilitating advanced safety features, enhanced navigation systems, and new entertainment options (Fig. 1). However, the growing number of these components poses a significant challenge for car manufacturers: ensuring seamless connectivity and interoperability between the various systems. One of the biggest challenges is managing local connectivity within the vehicle.

*Fast, reliable, and over longer distances*

MIPI (mobile industry processor interface) protocols on higher layers are commonly used in vehicles to connect sensors and displays with domain control units and other onboard computers. To facilitate communication between cameras, displays, and other onboard systems, data are traditionally transmitted us-

ing source-synchronous interfaces like MIPI D-PHY and MIPI C-PHY. While these interfaces are effective for short-range connections, they struggle with data transmission over longer distances within the vehicle.

To address this issue, cabling interfaces like MIPI A-PHY have been adopted for distributing cameras and displays within the vehicle. A-PHY is an asymmetrical data link in a point-to-point topology that enables very fast, unidirectional data transmission with embedded bidirectional control data and optional power supply via a single cable.

The use of A-PHY allows suppliers to achieve efficient transmission over longer distances – cable lengths of up to 15 meters – while ensuring fast, reliable, and efficient communication between various vehicle components. MIPI A-PHY v1.0 supports five speed levels (2, 4, 8, 12, and 16 Gbit/s), offering greater design flexibility. The latest version, MIPI A-PHY v1.1, doubles the total downlink bandwidth from 16 to 32 Gbit/s by supporting Star Quad (STQ) cables, which feature two differential wire pairs in a single shielded jacket. This enables the use of two A-PHY ports via a single cable, reducing costs, weight, and complexity compared to using two separate coaxial or shielded twisted pair cables.

*Bridge between various interface protocols*

However, the introduction of interface standards entails a number of challenges. Different suppliers use proprietary protocols or hardware interfaces, leading to compatibility

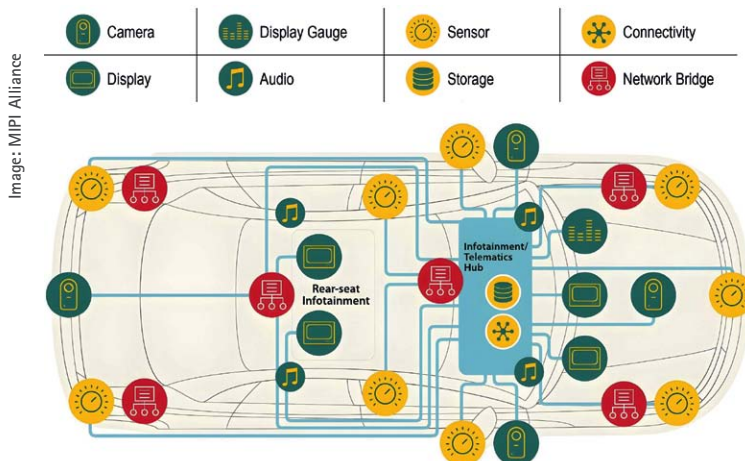

Figure 1: Distribution of cameras and displays in modern vehicles

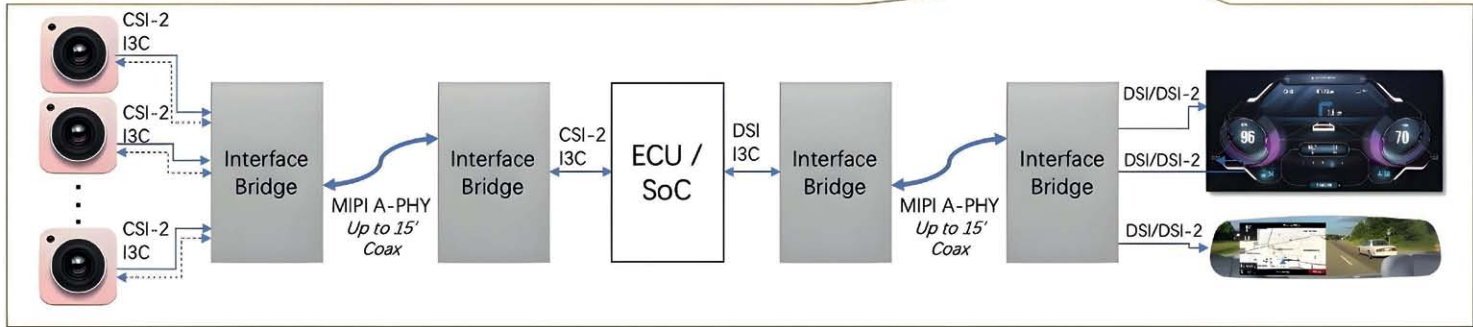

Figure 2: FPGAs can serve as intelligent interfaces between components that utilize different standards or protocols

issues and fragmented ecosystems. To simplify the introduction of interface standards, car manufacturers use programmable FPGA-based interface bridges.

These versatile solutions act as a bridge between different interface protocols and enhance compatibility and flexibility within the vehicle architecture. FPGA-based interface bridges enable the integration of multiple device interfaces, facilitating the aggregation, partitioning, control, and initialization of various components (Fig. 2).

They provide advanced functions such as pre-processing and buffering for real-time processing of camera and display data, for instance. With a latency of under 15 ms, FPGAs offer significantly lower response times compared to SoC-based solutions, which typically

have a latency of around 30 ms. They also support compression methods that allow for higher resolution and increased image and data rates via the cable connection. Car manufacturers can thus offer their drivers and passengers a cutting-edge visual experience without sacrificing performance or efficiency.

Another example of the use of Gowin FPGAs in automotive applications is LED backlighting control for in-cockpit display. This results in several significant advantages (Fig. 3): They offer cost-effective, customizable logic that facilitates rapid prototyping and precise control of LED brightness and color, enhancing display readability and driver comfort. Moreover, the FPGAs are designed for low power consumption, which is essential for energy efficiency in vehicles. They meet the stringent standards of the automotive industry in terms of reliability

and temperature resistance. Their integration capabilities support seamless connection to other vehicle systems and comprehensive control and monitoring on a single chip.

*Summary*

By employing FPGA-based interface bridges, car manufacturers can address the challenges of camera and display interfaces, ensuring seamless connectivity and standardized communication protocols within their vehicles.

These solutions not only improve the driving experience but also pave the way for innovations in automotive technology. As the industry evolves, FPGA-based interface bridges will be crucial in shaping the future of connected vehicles. ■

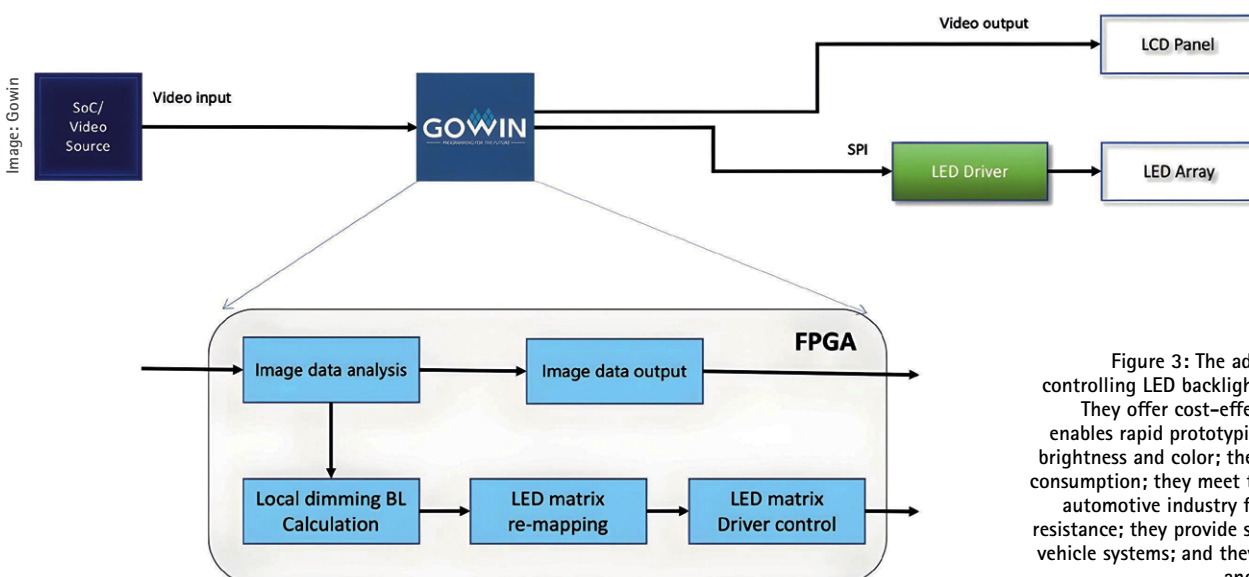

Figure 3: The advantages of Gowin FPGAs for controlling LED backlighting in automotive solutions: They offer cost-effective, customizable logic that enables rapid prototyping and precise control of LED brightness and color; they are designed for low power consumption; they meet the stringent standards of the automotive industry for reliability and temperature resistance; they provide seamless connectivity to other vehicle systems; and they offer comprehensive control and monitoring on a single chip.

All-in-one sensor platform for controlling indoor air quality

# Nine in one go

*A compact and powerful sensor platform measures up to nine environmental parameters – including particulate matter, CO<sub>2</sub>, or VOCs – and opens up the way for developing intelligent devices for enhanced energy efficiency, comfort, and well-being.*

BY VIDYA SRIRAM, CORPORATE PRODUCT MANAGER  
ANALOG & SENSORS AT RUTRONIK,  
AND  
ALINA SCHÜTZ, CHANNEL MARKETING MANAGER AT SENSIRION

**E**nvironmental conditions have a major impact on our well-being, comfort, and productivity. Air quality in particular plays a key role for human health and the environment. Particulate matter (PM2.5 and PM10) and volatile organic compounds (VOCs) can cause respiratory diseases and lead to chronic cardiovascular diseases or cancer.

Humans breathe out carbon dioxide (CO<sub>2</sub>) and breathe in oxygen (O<sub>2</sub>). Poor ventilation can cause CO<sub>2</sub> levels to rise rapidly in occupied spaces, possibly exceeding unhealthy limit values (over 2,000 ppm). Indoor air pollution is exacerbated by microscopic particles that enter from outdoors, originating from vehicles, industrial, or forest fires. Volatile organic compounds (VOCs), emitted during various activities and often partially harmful to both humans and the environment, are ubiquitous. A particularly harmful volatile organic compound is formaldehyde (HCHO), which can cause eye irritation and even cancer in high concentrations. Moreover, nitrogen oxides (NO<sub>x</sub>), primarily generated during combustion processes in vehicles or ovens, can harm the human respiratory system when present in high concentrations.

It is, therefore, essential to monitor and improve air quality. Accurately assessing air quality, however, demands a comprehensive, multifaceted approach. Since the detection of CO<sub>2</sub>, particulate matter or VOCs varies greatly due to the differing physical and chemical properties of these pollutants.

## Multifunctional sensor platform

SEN6x from Sensirion combines multiple sensor technologies in one compact package and can measure up to nine environmental parameters – particulate matter (PM1, PM2.5, PM4, and PM10), humidity (relative humidity, RH), temperature (T), VOC index, NO<sub>x</sub> index, CO<sub>2</sub>, or HCHO (Fig. 1). The humidity and temperature components provide precise measured values for a healthy and pleasant indoor climate. Additionally, integrated compensation mechanisms help offset temperature and humidity fluctuations that impact the measuring accuracy.

SCD4x in SEN6x utilizes a sensor that combines the principles of photoacoustic spectroscopy and NDIR techniques (non-dispersive infrared sensor) to monitor CO<sub>2</sub> values. The VO<sub>x</sub> and NO<sub>x</sub> values are measured using a metal-oxide gas sensor element (MO<sub>x</sub>). An electrochemical sensor is used to detect the formaldehyde values. These various elements enable the prompt initiation of air purification measures, such as demand-driven ventilation control, to ensure safe and efficient air quality management.

At the core of the platform is the particulate matter sensing component SPS6x. It integrates all the necessary building blocks for measuring PM1, PM2.5, PM4, and PM10. The measurement of particulate matter relies on light scattering, i.e. when particles in the air pass through the beam of an integrated laser,

## RELIABILITY WHEN IT'S NEEDED MOST

Seamless power  
connectivity for EV  
charging applications



*creating  
connections  
for life*



Figure 1: Sensing opens up new possibilities to create smarter devices that improve our comfort and well-being as well as increase energy efficiency in a wide variety of applications.

the light is scattered, which is then captured by photodetectors. Onboard algorithms analyze the scattered light to determine the size distribution and mass concentration of the particles. Thanks to an application-specific integrated circuit (ASIC), no external processing is needed, and SPS6x provides fully processed values through I<sup>2</sup>C communication.

Due to the combination of sensors, compensation algorithms, and acceleration motors, the combined module is ready for immediate use. Opting for SEN6x saves development time and costs, resulting in a short time to market with simplified development processes.

Further, the design of SEN6x complies with leading IAQ standards, such as Reset, Well Building Standard, and California Title 24 Building Energy Efficiency. As such, the sensor can be simply integrated into smart building projects. SEN6x provides a detailed insight into air quality parameters, thereby enabling a better understanding and control of the indoor climate. This maximizes the potential of air quality monitoring for use in smart building management. ■

Figure 2: The compact and powerful SEN6x sensing platform combines multiple sensors in a compact package and can measure up to nine environmental parameters (PM1, PM2.5, PM4, PM10, RH, T, VOC Index, NO<sub>x</sub> Index, CO<sub>2</sub>, or HCHO). The design simplifies integration, reduces costs, and allows for customization.







Automotive-qualified DFN package

# Compact, cost-effective and powerful

*DFN packages offer high power densities and excellent thermal properties thanks to an exposed heat sink and optimized heat path.*

*Side-wettable flanks also enable the automated optical inspection required in the automotive industry.*

BY THOMAS BOLZ,  
CORPORATE PRODUCT MANAGER  
STANDARD PRODUCTS AT RUTRONIK

**D**ual flat no-lead (DFN) packages are designed for harsh environments, offering resistance to temperature fluctuations, vibrations, and other stresses. Due to their reduced installation height, high reliability and optimized thermal properties, they are often employed in the automotive industry. Their compact design helps save space on the printed circuit board, which is absolutely essential in vehicles.

By eliminating protruding leads, the package is able to establish shorter signal paths, thereby minimizing signal delay and enhancing signal integrity – a critical factor in high-speed scenarios where precision is also paramount.

Despite the numerous advantages of DFN packages, they also present certain challenges that must be considered during design and

manufacturing. These challenges primarily revolve around assembly, soldering, inspection, and testing.

## *The challenges with DFN packages*

Various processes are generally used for soldering DFN packages, depending on the specific requirements of the design and the materials, components, and printed circuit boards used. Reflow soldering is the standard method when it comes to soldering SMD components. The components are initially positioned on the printed circuit board, which then passes through a reflow oven that maintains a precise temperature-time profile. The entire assembly is heated to above the melting temperature of the solder paste, which melts to

Advertisement

## New-Gen 3.5" and pITX SBC

Intel® Atom® x7000(R)E Series, Intel® Core™ i3 N-Series  
13th Gen Intel® Core™ U-Series Processors

 Extreme temperature

 Real-time processing

 AI Acceleration

 Wide voltage input

**kontron**  
The Power of IoT



CE UK FC c RU US



Image: Rutronik

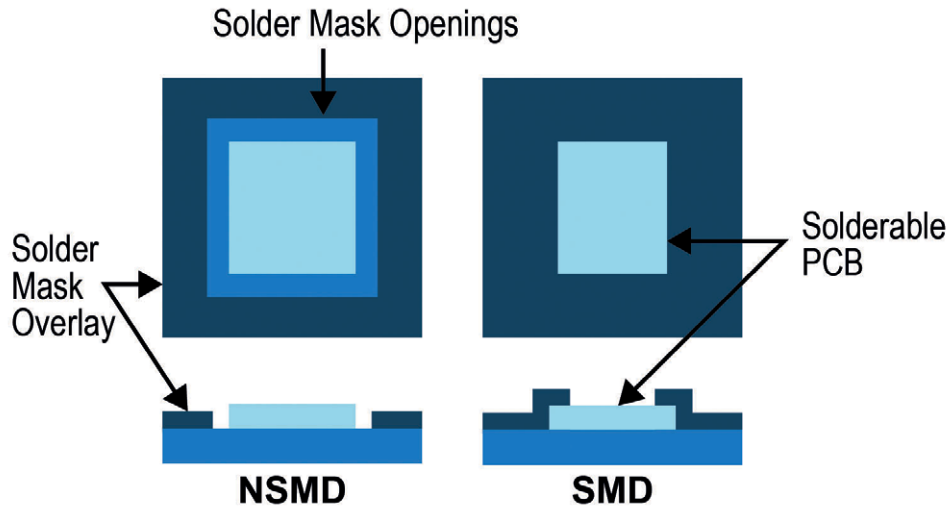

Figure 1: DFN packages are assembled on NSMD pads to ensure the solder can run up the side flanks, in contrast to standard SO-IC packages, which are assembled on SMD pads.

Image: Vishay

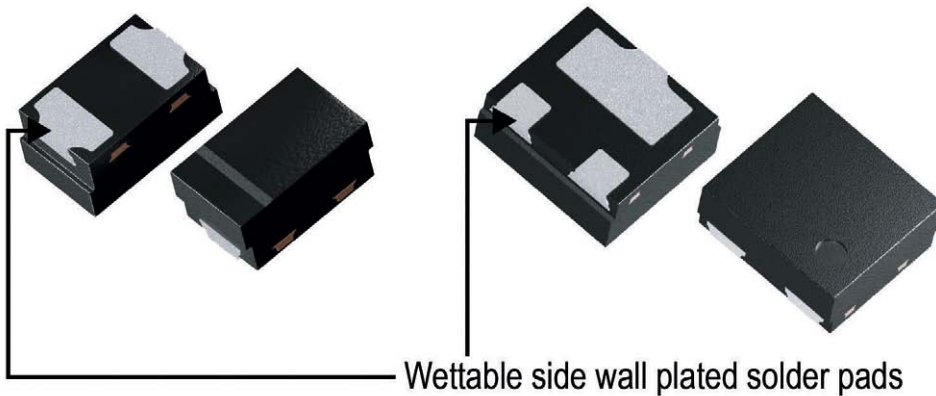

Figure 2: Side-wettable flanks of DFN packages

Image: Vishay



Figure 3: Sketch of the solder meniscus. This can be inspected with an optical camera system to assess the solder result.

form the solder joints. The result is uniform and reliable solder joints. The process is well suited for large-scale production.

Furthermore, soldering DFN packages demands a high level of precision. In particular, the amount of solder paste on the bottom terminal pads must be carefully checked to ensure reliable electrical connections. Inadequate solder paste may result in weak or absent connections, while excessive paste can lead to solder bridging or short circuits between adjacent pads. Appropriate solder paste stencils and stencil designs, precise placement

equipment, and optimized reflow soldering profiles must be selected and used to guarantee the integrity and reliability of the solder joints. Additionally, considerations such as pad design, solder mask application, and side-wettable flanks must be integrated into the assembly workflow (see [Vishay application note: Soldering Recommendations for Power DFN Packages](#)).

Two types of solder masks are commonly used for surface-mounted leadless packages: solder mask defined (SMD) and non-solder mask defined (NSMD) (Fig. 1). With the SMD type, the

solder mask partially covers the pads and prevents the solder from flowing over the edge of the SMD pad. With the NSMD pad type, the opening of the solder mask is larger than the solder pad. A gap forms between the solder pad and the solder mask, into which the solder flows and strengthens the joint. The choice between SMD and NSMD depends on several factors, including the design requirements, component pitch size, thermal considerations, and the desired reliability of the solder joint.

Ensuring the quality and reliability of printed circuit boards (PCBs) is of great importance. One of the key contributing technologies is automated optical inspection (AOI). This technology-driven method enables the automatic inspection and analysis of printed circuit boards, allowing for the detection of various issues, such as absent or misaligned components and soldering defects. Other anomalies that can negatively impact the functionality or reliability of a printed circuit board are also identified.

The X-ray inspection is also known as automatic X-ray inspection (AXI). AXI is particularly suitable for inspecting concealed solder joints and internal structures. However, it is not as effective as AOI in terms of detecting surface defects.

*Solder joint inspection for DFN*

DFN packages feature an exposed pad and connectors on the underside, eliminating visible solder joints from the package design. It is therefore difficult to visually determine whether the package has been soldered effectively. Electrical testing is often the only practical way to verify the quality of the electrical connections of the solder joints. However, for applications that require a high level of reliability, it may be necessary to visually check the integrity of the solder joints. For instance, the automotive industry demands that original equipment manufacturers perform a 100 percent automatic visual inspection after assembly.

In order to be able to inspect the typically invisible solder joints underneath DFN packages, these packages can be designed with side-wettable flanks (SWF) (Fig. 2). This allows a solder meniscus to form on the sides of the DFN package, which can be inspected using AOI (Fig. 3). This results in a further advantage: the mechanical strength and stability of the joint to the printed circuit board is better



Figure 4: Ultra-fast 200 V FRED Pt rectifier in a flat DFN3820A package from Vishay

than with components without side-wettable flanks. SWFs thus reduce the risk of failures due to shear forces and printed circuit board bending.

*Space-saving solutions  
with a high level of efficiency*

Vishay Intertechnology offers four new series of ultra-fast 200 V FRED-Pt rectifiers in the flat DFN3820A package with side-wettable flanks. They guarantee space-saving, highly efficient solutions for cutting-edge power applications.

These 1 A to 5 A, 200 V FRED (fast recovery epitaxial diode) Pt (platinum doped technology) rectifiers ensure reduced space requirements, enhanced thermal performance and greater efficiency.

Compared to components in SMP packages (DO-220AA) with the same footprint, the

VS-1EAH02xM3, VS-2EAH02xM3, VS-3EAH02xM3, and VS-5EAH02xM3 models feature a 12 percent lower installation height and more than double the current carrying capacity. Each model is also available in Vishay Automotive Grade AEC-Q101 qualified versions (Fig. 4).

Typical applications in the automotive industry include dual-voltage injector drivers, piezo drivers, and engine control units (ECU), advanced driver assistance systems (ADAS), LiDAR, cameras, and anti-lock braking systems (ABS), as well as 48 V electrical systems, chargers, and battery management systems (BMS) in electric and hybrid vehicles (HEV). ■

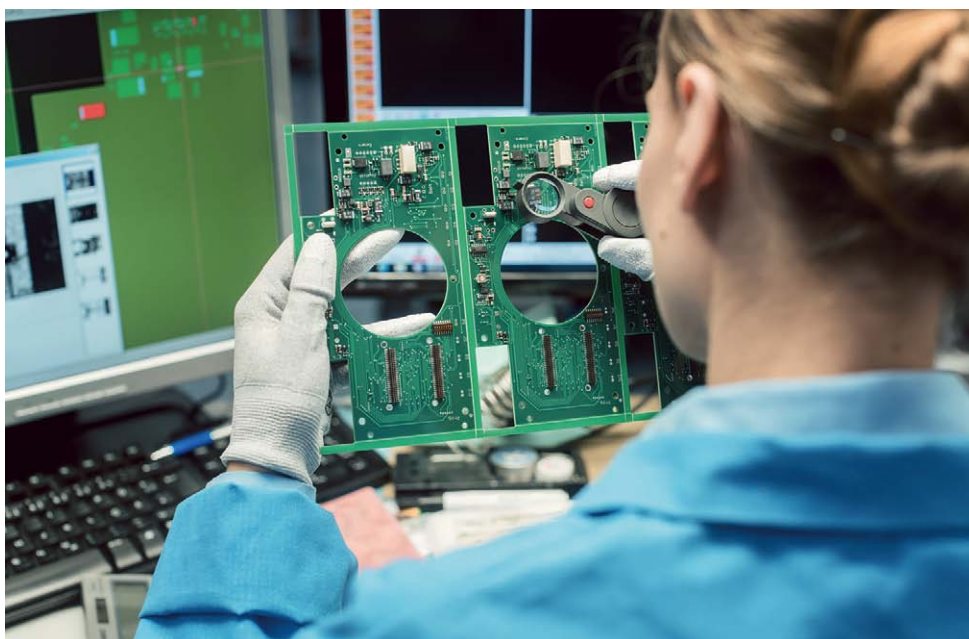
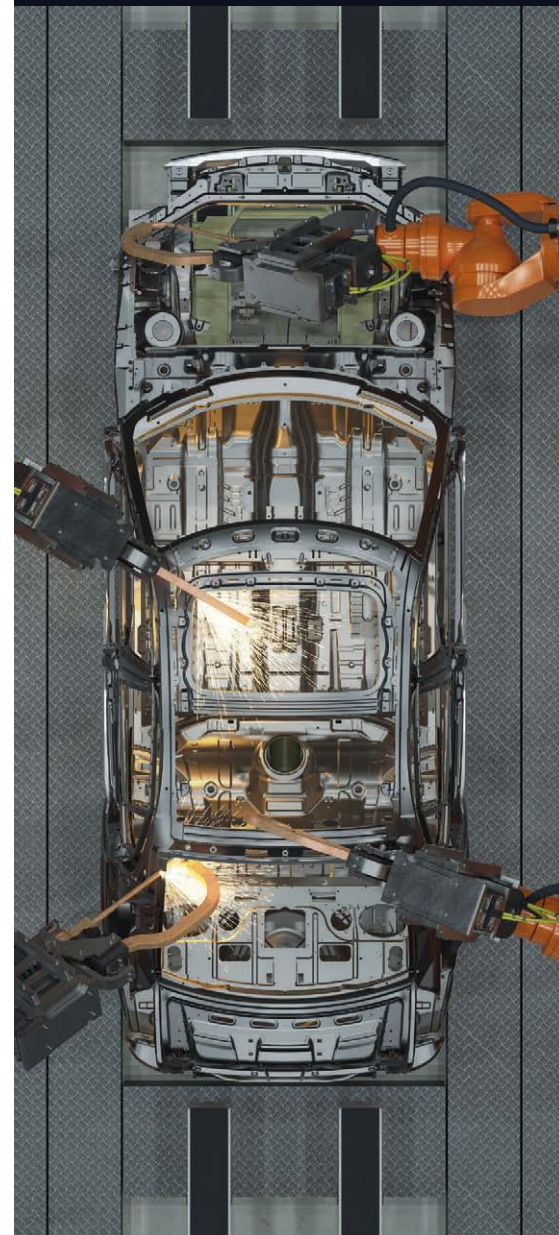

Image: kzenon/Shutterstock.com

Visual quality and assembly inspections can pose a challenge with DFN packages.

## TRANSFORMING TRANSPORTATION

Rugged and reliable solutions for demanding applications



*creating  
connections  
for life*



How ProFET Wire Guard protects the electrical system and its components

# Short circuit? Not a problem.

*PROFET Wire Guard is ideal for 12 V power distribution in functional safety-related applications. This is due to its diagnosis and protection properties, autonomous operation when a vehicle is parked, and the available safety documents.*

BY RALF HICKL, PRODUCT SALES  
MANAGER IN THE AUTOMOTIVE  
BUSINESS UNIT (ABU) AT RUTRONIK

**M**elting fuses have two main features. They do not require an auxiliary power supply and, therefore, do not consume power themselves, thus preventing the battery from slowly draining while the vehicle is parked. And if chosen correctly, they protect the power lines in the wiring harness due to their  $I^2t$  characteristic as the weakest link in the wiring chain. However, as automated driving functions advance, the demands on the 12 V electrical system are forever increasing, making traditional melting fuses inadequate.

In a highly automated vehicle (ADAS level L2 and higher), a short circuit in one part of the electrical system must not affect critical components in other areas or the redundant electrical system. Such faults need to be detected and isolated immediately in order to

protect other consumers and the voltage source.

An eFuse must therefore offer additional performance features, such as:

- adjustable triggering characteristic, adapted to the load and the line cross-section,
- low dispersion of the triggering characteristic,
- fast activation in  $\mu\text{s}$ ,
- reset-ability via electrical signals or bus communication,
- diagnosis feedback,
- suitability even with capacitive load-switching, and
- support of developments according to ISO 26262 in terms of functional safety.

## *eFuses with new functions*

The new PROFET (Protected Field Effect Transistor) Wire Guard family from Infineon offers a range of new features: The integrated and adjustable  $I^2t$  function protects wires from overheating. Six  $I^2t$  protection curves can be selected via an external resistor depending on the cross-section of the connected wire (Fig. 1). The temperature model in Wire Guard operates onboard and does not require any assistance from an external microcontroller. This ensures protection even when the  $\mu\text{C}$  is in standby mode or going through a reset cycle.

The triggering threshold for fast overcurrent shutdown can also be set via an external resistor. It protects the voltage source (e.g. battery or zone controller) and other consumers



from short circuit feedback. Harmful feedback can result in extended periods of undervoltage, causing other control units to undergo an undervoltage reset and become unavailable for the driving function. PROFET Wire Guard supports applications with fail-operational architecture by providing rapid error detection and failure isolation in the event of overcurrent.

The diagnosis feedback of the module allows various status and actual values to be read sequentially via one single pin. The status and actual values include the actual current value, the selected I<sup>2</sup>t protection curve, the I<sup>2</sup>t status, and the threshold value for overcurrent shutdown.

At low load currents, PROFET Wire Guard automatically switches from I<sup>2</sup>t mode to IDLE mode. In idle mode, Wire Guard reduces current consumption to around 50 µA with a fully controlled switching transistor and active protection functions. Thanks to the energy-saving idle mode, Wire Guard is particularly suitable as an eFuse for system sections and loads that are active during parking.

Thanks to the capacitive load-switching (CLS) mode, Wire Guard is also ideal for fast charging and switching on large capacitive loads. Such a capacitive load can, for example, be the DC link capacitors of a motor inverter. To activate CLS mode, the Wire Guard input is controlled with a defined PWM signal. This PWM signal sets the module to CLS mode with the "continuous auto restart" switch-off strategy. The switching cycles "switch on and supply with defined maximum current" and "switch off due to protection against steep temperature rise" are repeated until the voltage drop at the output transistor, in on-state, falls below a certain value. In this case, the capacitive load is considered sufficiently charged. After that, the PWM signal is permanently switched through and can be replaced by a high level at the control input. Advantage: The module remains in the specified safe operating area (SOA) during this period.

#### Extended product family

Infineon has added several derivatives to the PROFET product family. Load Guard without I<sup>2</sup>t emulation is intended for lower currents up to approx. 5 A. Moreover, when currents reach critical levels for wiring, Wire Guard products come into their own (Fig. 2). They are ideal for use in 12 V power distribution and in zone controllers that operate in an ASIL-

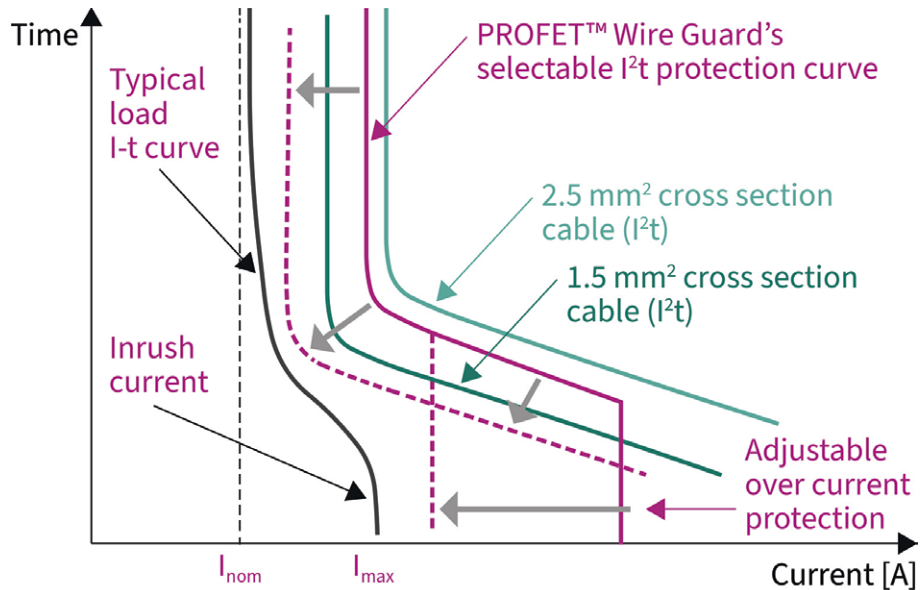

Figure 1: Load curve, load capacity of the wiring, and triggering curves of PROFET Wire Guard. One of six selectable I<sup>2</sup>t protection curves and the adjustable overcurrent threshold protect the load, source, and wiring.

classified system and ensure a fail operational concept.

Populated evaluation printed circuit boards with Wire Guard or Load Guard are available for test purposes. These daughterboards fit on the PROFET One4All motherboard. Wire Guard can then be configured and tested using a PC GUI (Infineon Smart Power Configuration Switches Wizard) via an interface converter (µIO stick).

power consumption, and available safety documents, it is ideally suited for use in 12 V power distribution in terms of functional safety. Wire Guard reliably protects the entire circuit consisting of the source, Wire Guard itself, wiring, and load. ■

#### Summary

PROFET Wire Guard from Infineon is well on the way to becoming the ideal eFuse. Thanks to its diagnosis and protection properties, low

Load current range	PROFET™ Wire Guard		PROFET™ Load Guard
	TSDSO-14	TSDSO-24	TSDSO-14
40 A			
25 A – 30 A			
19.7 A – 23.3 A		BTG70013A-1ESW	
16.7 A – 17.8 A		BTG70020A-1ESW	
14 A – 15.5 A	BTG7003A-1EPW		
11.5 A – 12.9 A			
9 A – 10.5 A	BTG7007A-1EPW		
8 A – 8.6 A			
6.1 A – 7.3 A			
5.1 A – 5.7 A	BTG7016A-1EPW		
4.2 A – 4.9 A			BTG7050-1EPL
3 A – 3.9 A			BTG7050-2EPL
2 A – 2.9 A			BTG7090-1EPL
1.4 A – 1.9 A			BTG7090-2EPL

Figure 2: Overview of the latest derivatives of the PROFET product family. Load Guard without I<sup>2</sup>t emulation is intended for lower currents up to approx. 5 A. Moreover, when currents reach critical levels for wiring, Wire Guard products come into their own.



Top-side cooling for better heat dissipation of automotive MOSFETs

# Better cooling performance in a compact design

*For effective component performance, continuous advancements in both MOSFET and package technology are essential.*

*The new OptiMOS series in the SSO10T package is a robust solution for optimizing performance and reliability.*

BY RALF HICKL,  
PRODUCT SALES MANAGER  
IN THE AUTOMOTIVE BUSINESS UNIT (ABU)  
AT RUTRONIK

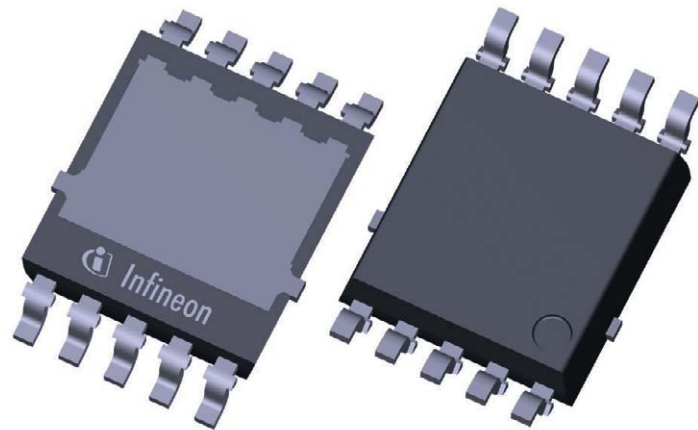

Images: Infineon

Figure 1: The SSO10T 5x7 package with top-side cooling

According to Infineon, more than 120 MOSFETs will be installed in every passenger car with a combustion engine by 2025. Key drivers of growth are legislation in CO<sub>2</sub> reduction, the expansion of driver assistance systems, and applications aimed at enhancing occupant comfort. Reasons enough for suppliers to increase their production capacities and advance MOSFET technology.

*Package and semiconductor chip determine the properties of MOSFETs*

The properties of a packaged MOSFET are determined both by the package and the MOSFET die, i.e. the actual semiconductor chip. The overall electrical resistance of the component is the combination of the  $R_{DS(on)}$  of the die (chip) and the electrical resistance of the package connection. The smaller the  $R_{DS(on)}$  of the MOSFET die, the greater the percentage of the electrical resistance of the package connection in relation to the overall resistance. The respective spice models provide an

indication of the distribution of the overall resistance between the actual  $R_{DS(on)}$  of the chip and the power resistance of the package. The spice models of Infineon MOSFETs are generally unencrypted and available on the home page.

As soon as current flows through the component, conductivity losses arise according to the following equation:

$$P_{tot} = I^2 \cdot R_{DS(on)}$$

The resulting heat must be dissipated into the environment. This requires the lowest possible thermal resistance  $R_{thJA}$  between the die and the outer surface of the package.

*Efficient cooling is crucial for performance and reliability*

In the automotive industry, MOSFET dies are frequently engineered to withstand high temperatures and harsh environments, ensuring they meet the demands of vehicle operation.

Nevertheless, cooling the MOSFETs is crucial for performance and reliability. This is often accomplished through the use of highly conductive materials, optimized heat sink designs, and efficient heat dissipation methods. Top-side cooling is ideal for automotive MOSFETs, as the active components that generate heat during operation are situated on top of the chip. Effective top-side cooling can be achieved using thermal pastes, thermal films, heat sinks, and various other thermal solutions. By dissipating heat from the top-side of the MOSFET, the operating temperature is reduced, thereby improving the performance, reliability, and service life of the component.

To ensure effective component performance, continuous advancements in both MOSFET and package technology are essential. The new OptiMOS-MOSFETs in an SSO10T package serve as a prime example of this (Fig. 1).

In the OptiMOS6 series for 40 V (Table 1) and OptiMOS7 series for 80 V (Table 2), both featuring an SSO10T package, the dies are contacted in a plane manner using copper clips rather than thin wires. This method ensures excellent thermal and electrical connection between the chip and the package. Heat is mainly dissipated via a contact surface on the top -side of the package.

Thermal interface material (TIM) can be used for the thermal connection to a cooling surface. These films or pastes level out any unevenness and roughness of the surfaces. Depending on the material, the films also provide electrical isolation between the component and the cooling surface. Rutronik stocks thermal interface materials, e.g. from Fischer Elektronik and Innotape.

*High power density – even in limited installation spaces*

The advantages of the top -side cooling of MOSFETs are many. In addition to an increase

Group	Product	max. $R_{DS(on)}$ [mΩ]	$I_D$ (DC current) [A]	$I_D$ (chip limitation) [A]	$Q_G$ typ. [nC]	$V_{GS(th)}$ [LL/NL]
2	IAUCN04S7N006T	0.62	165	540	122	NL
1	IAUCN04S6N007T	0.75	120	390	100	NL
1	IAUCN04S6N009T	0.90	120	330	85	NL
1	IAUCN04S6N013T	1.32	120	230	52	NL
1	IAUCN04S6N017T	1.73	120	200	37	NL

Table 1: Infineon's product portfolio for 40 V MOSFETs of the OptiMOS 6/7 series with an SSO10T package

Group	Product	max. $R_{DS(on)}$ [mΩ]	$I_D$ (DC current) [A]	$I_D$ (chip limitation) [A]	$Q_G$ typ. [nC]	$V_{GS(th)}$ [LL/NL]
1	IAUCN08S7N016T	1.6	165	235	20	NL
2	IAUCN08S7N019T	1.9	165	203	TBD	NL
2	IAUCN08S7N024T	2.4	165	167	TBD	NL
2	IAUCN08S7N046T	4.6	100	100	TBD	NL

Table 2: Infineon's product portfolio for 80 V MOSFETs of the OptiMOS 7 series with an SSO10T package

in overall efficiency, more compact designs are possible. This approach allows the thermal flow resulting from the power loss of the MOSFETs to be transferred directly from the component surface to a cooling surface or heat sink. There is no longer a need for diversion through the printed circuit board. This helps reduce the thermal resistance between the MOSFET and the heat sink. The printed circuit board can thus be less complex. Thermal vias and the insulated metal substrate (IMS) embedded in the PCB, which otherwise reduce the heat resistance of the printed circuit board, are no longer needed.

The effective heat dissipation enhances thermal impedance by 20 to 50 percent (Fig. 2), which boosts the operating temperature range or enables the components to achieve greater performance at the same operating temperature. The design also supports higher application currents, which can replace larger packages and provide additional space savings, for example. Top-side cooling in combination with the OptiMOS 40 V family enables higher power densities, which is crucial in applications with limited installation space.

Furthermore, the Infineon SSO10T package is listed as LHDSO-10 JEDEC, which makes it easier to interchange with components from other suppliers. The availability of second sources is a key selection criterion, enhancing the customer's supply assurance for the placement location on the PCB.

Typical automotive applications for top-side cooling MOSFETs are electric power steering, electric brakes, power distributors, and electric auxiliary drives. The design allows for a thermally optimized mechanical construction, resulting in higher power densities and system-level savings. Other suppliers offering MOSFETs with top-side cooling include, e.g., Vishay and Toshiba.

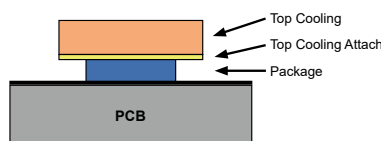
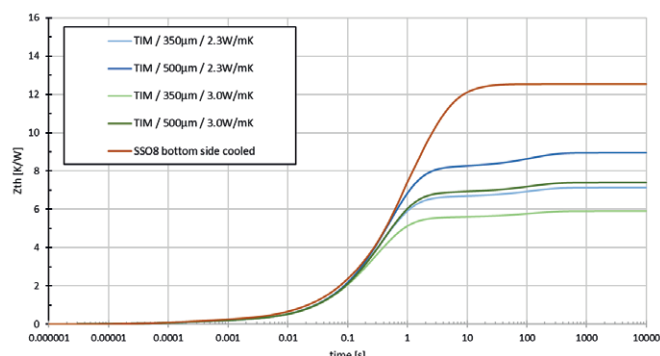

- $T_{ambient} = 85^{\circ}C$
- $P_{Loss} = 5W$

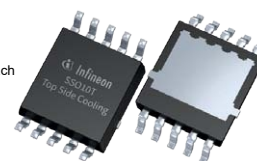

Figure 2: Comparison of thermal impedance across pulse durations with various thermal coupling methods: Depending on the material and thickness of the thermal interface, the thermal resistance is reduced by 20 to 50 percent (left). Design of the top-side cooling (right).

CEO interview

# Rutronik as a trailblazer, advisor, and partner

*Amid a period of economic uncertainty and volatile markets, Rutronik plays a key role as an trailblazer, advisor, and partner in the electronics market. CEO Thomas Rudel offers insights into the current challenges and opportunities at the intersection between suppliers and customers.*

**The overall economic outlook this year is less than stellar, with many companies exhibiting cautious or uncertain ordering behavior. What are you observing at the intersection between suppliers and customers?**

*Thomas Rudel:* Manufacturing planners in Germany are still very hesitant, even though the current situation is much less precarious than it was during the COVID-19 pandemic or the banking crisis, for instance. We are noticing significant inconsistencies in ordering patterns, following a stop-and-go approach that includes cancellations and, at times, substantial double bookings.

This has consequences for overall economic activity. In boom phases, massive overbooking quickly occurs and storage facilities fill up ac-

ordingly. This can lead to cash flow problems and ultimately to overproduction on the part of component suppliers. Our in-house analysts, but also industry analysts, anticipate that periods of shortages and oversupply will alternate more rapidly. Historical comparisons also indicate that the frequency and amplitude of fluctuations in the Purchasing Managers' Index (PMI) are increasing. This is an indicator of faster changes between shortages and oversupply.

**What are your key strategies in response to the current uncertainty among customers?**

We are in constant exchange with suppliers and customers. As a distributor, it is essential for us to act as both a seismograph and a mediator between the various market participants. With this in mind, the market research-

ers of our Strategic Marketing team conducted a survey in the first quarter of 2024 to gauge our customers' perspectives on the normalization of the economy. By March, so quite early on in 2024, over a third of the more than 140 customers surveyed from Germany, Austria, and Switzerland indicated that they no longer anticipated normalization this year. Just under a third expected recovery in the current fourth quarter. For several months now, we have also noticed that many companies tend to delay placing repeat orders. This obviously increases the risk of renewed allocation.

**What conclusions can you draw from this for your business activities?**

As a broadline distributor, we have access to an extensive product portfolio. We are there-

HESS - HYBRID ENERGY STORAGE SYSTEM



## January 2024

The HESS from Rutronik System Solutions on the Elektronik shortlist as Product of the Year 2024 in the category Power



## March 2024

Launch of the Adapter Board RAB4 for RTK (real-time kinematics) from Rutronik System Solutions

Growth through transformation



New image film out now

## February 2024

Release of the new corporate movie

## April 2024

Adlink is a new partner: Handshake between Xavier Serra, Director Distribution Network EMEA at Adlink Technology (left), and Bernd Hantsche, Vice President Product Marketing Embedded & Wireless at Rutronik







Thomas Rudel, Rutronik CEO

*“Our customers also appreciate our independence when it comes to giving advice, as it allows us to always find the best solution for them.”*

tainable growth. Our customers also appreciate our independence when it comes to giving advice, as it allows us to always find the best solution for them.

**What is your greatest advantage as a medium-sized, owner-managed company in comparison to large corporations?**

As a distributor, we provide many SMEs with the sole access point to the electronic components they need from the suppliers. Moreover, we speak the language of medium-sized customers and are aware of the challenges they face, also in the field of research and development, which often differ from those faced by large corporations. We therefore maintain close contact with both suppliers and customers. This also ensures that we know the challenges our customers have to deal with, enabling us to provide top-level advice with synergistic benefits.

fore able to offer alternatives. Nevertheless, stronger economic policy support remains crucial to boost Germany and Europe's independence. In Europe, funding and subsidy programs are often too short-sighted, typically supporting only the development of front-end production capacities. Investments in development, design, and expertise do not appear to be top of the agenda for policymakers.

In this context, I see further potential in adopting a pragmatic political approach aimed at easing the burden on the local SME sector. We definitely need to streamline bu-

reaucratic processes to enhance Europe's resilience.

**Why do you believe focusing on the SME sector is key to unlocking the potential of the European economy?**

I see a trend of long-term and consistent growth in the SME sector. As a medium-sized company, we also focus on achieving long-term growth through healthy and self-financed means. The typical practice of meeting quarterly targets, which is often mandatory for capital market operators, is alien to us and many other SMEs that we work with as customers. Furthermore, we are still an owner-managed company. This approach helps level the playing field with our customers and supports our long-term strategies through sus-

With Rutronik System Solutions, our goal is to empower our medium-sized customers in precisely these areas. This strategy of in-house development with partially patented solutions is unique for a distributor. It fosters completely new approaches to hardware and software development. The developer boards allow our

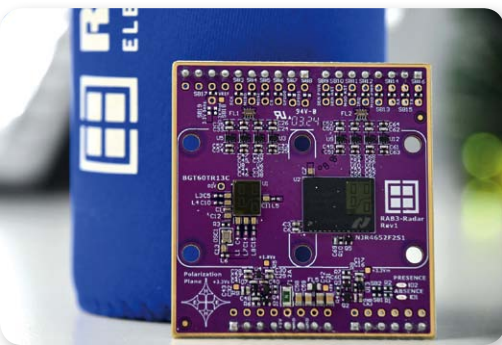

**May 2024**

Launch of the Adapter Board RAB3 for radar from Rutronik System Solutions



**July 2024**

Award as Distributor of the Year in the categories Volume Distributor and Sustainability

**June 2024**

Rutronik at the PCIM Europe 2024 in Nuremberg



**August 2024**

Infineon presents Rutronik the "Best Automotive Demand Creation Award 2024".



customers to significantly shorten their time to market and gain an innovative edge, even if they do not have hundreds of engineers at their disposal like large corporations do.

**And what are the reasons for retaining the company headquarters in Ispringen?**

I think I need to elaborate a little bit about this. At Rutronik, we can look back on more than five decades in the electronics market. My father, Helmut Rudel, founded Rutronik in 1973 and strategically chose Ispringen, near Pforzheim, as its location. He saw an opportunity in the fact that many Germans were particularly keen to watch the 1974 Soccer World Cup, which was being held in Germany for the first time, on a new TV set. At that time, many German suppliers like Grundig, Loewe, Schaub Lorenz, and Metz were based in southwest Germany. Even today, southern Germany remains renowned for its high concentration of successful SMEs, many of whom are world leaders in their respective sectors. We continue to be a strong partner for the SME sector. Therefore, despite the many challenges, the location remains essential. Our investment in our new location in Germany, for example the new office in Karlsruhe, which opened in January 2024, reflects our confidence in the region's potential.



If you want to discover more about the company's development, I recommend watching our new and entertaining corporate movie.

**And what is different to 50 years ago? Who are your current customers, and what makes them depend on you as their business partner and supplier of electronic components?**

This summer, Germany hosted the EURO 2024 soccer tournament. Let me highlight once more the significance of the 1974 Soccer World Cup, which played a pivotal role in our company's history. Today, electronics enable much more than just the viewing experience in front of a screen, especially in the realm of sensor technologies.

Here are just two examples among many that I would like to share with you briefly. Soccer tracking systems use a range of sensors to gather detailed data on players throughout tournaments and training sessions. GPS or real-time kinematic sensors measure, for instance, geographic positions and movements with high precision and frequency, which is essential for dynamic sports like soccer. In addition to their use on the pitch, sensors are also utilized within stadiums to monitor crowd movement and to manage admission. Radar technology is, once again, an exciting field.

The reason why I mention this: This year, we introduced two adapter boards from Rutronik System Solutions specifically designed to support these technologies, RAB4 for real-time kinematics (RTK) and RAB3 for radar, thus enabling our customers to test their respective applications. This could be in the field of sports, but our customers primarily utilize

these benefits in applications within the smart factory, smart home, smart farming, and health care sectors.

**Rutronik's in-house research and development activities are fascinating. Where do you see Rutronik in the future, and how do you plan to develop the company further?**

We know the requirements and challenges of the industry and are constantly analyzing the market. Therefore, by the middle of this year we had already established global partnerships in the wireless sector with Adlink and Cherry Embedded Solutions, as well as with VIA Technologies in Europe.

Our new Rutronik IT Electronics division was launched about a year ago. The advantage for us lies in the fact that this expansion of our portfolio enables us to provide both individual components and complete systems from under one roof. Rutronik IT Electronics and Rutronik Embedded, which specializes in industrial, medical, and automotive computer solutions, are closely interlinked. The collaboration allows us to blend commercial and customized components to create an optimal solution for our customers. The Rutronik Automotive Business Unit is celebrating its 10<sup>th</sup> anniversary this year. Over the past decade, it has been developing automotive reference designs in collaboration with manufacturing partners to boost the predevelopment efforts of our customers.

Our goal is to continue providing equal support to customers in both the industrial and the automotive sector. We aim to do so primarily through system solutions, making the most of our extensive experience in consulting and design-in. Key applications that our customers are researching and bringing to market are at home in areas such as Industry 4.0, (I)IoT, Future Mobility, and Energy and Power. And we are their enabler, advisor, and partner in this respect. ■

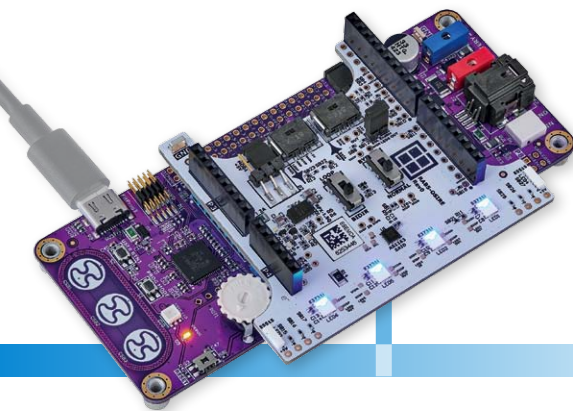

**September 2024**

Launch of the Adapter Board RAB5 – OSIRE from Rutronik System Solutions. On the picture: the RAB5 Adapter Board on the RDK4 Base Board

**October 2024**

The Rutronik Automotive Business Unit (ABU) is celebrating its 10<sup>th</sup> anniversary.



of success stories



Integrative view of hardware and software

# Joining forces for high-performance AI applications

*In October 2024, Rutronik announced its investment in the AI specialist collective mind. Joint projects in logistics and goods management with AI-based camera technology are already underway at the logistics center in Eisingen, Germany. In this article, the two partners outline their plans for the future.*

BY ELVIS KUKO, HEAD OF OPERATIONS AT COLLECTIVE MIND, AND CHRISTIAN KREBS, HEAD OF PROJECT & PROCESS MANAGEMENT AT RUTRONIK

**A**rtificial Intelligence (AI) applications and tools are increasingly penetrating entire industries and the business world. AI tools have the potential to make supply chains more efficient, automate inventory management, and optimize customer service, which is critical to stay competitive. As a distributor for many medium-sized companies (SMEs) in Germany, Europe and beyond, Rutronik aims to play a pioneering role with this investment.

As a result of the tense economic situation, SMEs are under increasing cost pressure. Efficiency and productivity are therefore becoming more and more important. "Especially in these difficult economic times, we want to send a signal from southwest Germany to decision-makers and other entrepreneurs in Germany and Europe," said Thomas Rudel, CEO of Rutronik, explaining the investment in light of the current economic downturn. "We want to encourage them to tackle the economic upturn together by focusing on strategically consid-

ered investments and by joining forces," continued Thomas Rudel.

*Joining forces to create groundbreaking AI solutions*

In order to secure a time advantage in the development of efficient AI applications for customers, Rutronik and AI specialist collective mind are working on AI applications for logistics, goods management, and industry. The common goal is to combine the strengths of both perspectives. In addition to its logistics and distribution expertise, Rutronik's main contribution is its hardware expertise at the product level of electronic components. This is already being tested together with collective mind's software expertise in AI-based image processing methods in practical scenarios such as logistics and shipping.

The integration of hardware and software is a challenge, as it cannot be offered from a single



Images: Rutronik



Figure 1: Successful talks on Rutronik's investment in collective mind with the announcement of the partnership at the beginning of October 2024 (from the left): Fabian Plentz, Chief Operating Officer (COO) of Rutronik, Armin Bär, Managing Director of collective mind, Thomas Rudel, CEO of Rutronik, Joshua Raabe and Artur Hefner, both Managing Directors of collective mind

source. The collaboration between the two partners aims to understand and deliver AI applications in terms of hardware and software integration for the first time (Fig. 2). "Through our investment in collective mind, we can now offer this on the market for the first time. The trend is towards complete embedded solutions with powerful, compact hardware for compute-intensive AI applications," said Fabian Plentz, Chief Operating Officer (COO) of Rutronik, explaining this important step in the company's strategy. "We are joining forces with Rutronik with the aim of offering internationally scalable software and hardware solutions developed from a single source for AI applications in retail and industry, among others, based on the regional ties between our two companies," said Artur Hefner, one of the Managing Directors of collective mind with a focus on operations and finance.

Specifically, collective mind aims to become the international number one for these AI solutions in the field of computer vision applications in industry and trade, with Rutronik's expertise as a long-standing distribution partner for many medium-sized companies in Europe, Asia, and North America. "We have ambitious goals, but our first joint project successes speak for very promising AI-based logistics solutions," continued Armin Bär, Founder and Managing Director of collective mind, with a focus on business development and sales. "We are pushing ahead with major growth potential with related development

projects in the industrial environment, especially in the field of vision robotics," added Joshua Raabe, Managing Director for technology at collective mind, outlining the medium-term plans of the AI specialist.

*Computer Vision for intelligent applications in manufacturing and distribution*

In the field of Computer Vision (CV), collective mind has extensive expertise in the development of AI-based image recognition and image processing applications. For this purpose, camera images are evaluated in a manner similar to the visual center of the human brain to extract the required information. This enables machines to use camera images to recognize what is happening around or inside them. Thus, they react autonomously and in-

telligently to various incidents in the shortest possible time. AI technology is used to automate image processing. In this field, collective mind was the first company in Germany to develop a certified safety assistance system based on camera-based object and sequence recognition.

*Use case electronic components logistics with > 100,000 parts*

Specifically, AI-supported image processing is being used in logistics in collaboration with collective mind to accelerate the growing demand for traceability at the product level. Rutronik, with its more than 100,000 electronic components and the associated variable recording data, is ideally suited as a use case for testing this development.



## About collective mind

Founded in 2010, collective mind GmbH, based in Leonberg near Stuttgart, Germany, started with software development and consulting. In 2018, the focus shifted to the development of AI applications in the field of computer vision. These can be operated autonomously by customers via a specially developed platform. The com-

pany's deep AI expertise is constantly being expanded in cooperation with scientific institutes and universities.

collective mind was the first company in Germany to certify an AI-based safety assistance system and continues to work on cutting-edge AI products for customers.

# UNIQUE GLOBAL INNOVATIONS THROUGH SYNERGIES AND TRUST

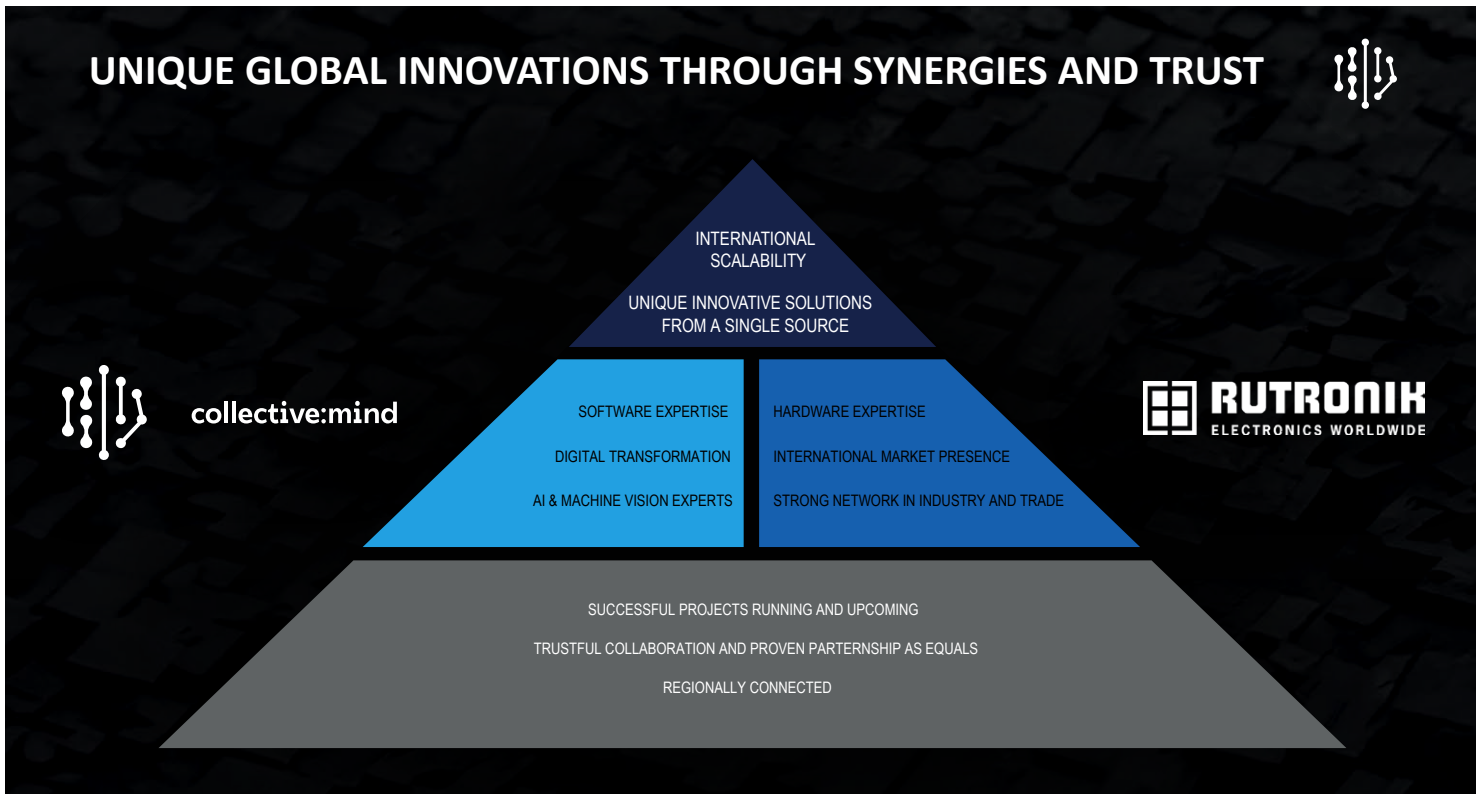

Figure 2: Potential synergies in the development of AI applications between the two partners

In production and logistics environments that increasingly rely on digitalization and automation, the automated processing of documents such as delivery notes is a decisive step towards increasing efficiency. Rutronik's use case in component logistics shows how the use of modern technologies such as OCR (Optical Character Recognition) and Large Language Models (LLM) enables end-to-end automation of this process. A delivery note scanner has been developed for this purpose.

The process starts with scanning a delivery note and sending it to an application. OCR technology is then used to "read" and digitally capture all the writing on the delivery note. The first LLM is then used to analyze the ex-

tracted data and determine the supplier based on the OCR result. Based on the identified supplier, the associated product names and other relevant information are retrieved from a linked database. This information is then passed as instructions to a second LLM. This second LLM specializes in extracting all the important core information from the OCR result – from product details to quantities and prices. Finally, the results are displayed in a user-friendly front-end, so that all important information can be accessed quickly and efficiently for further use in the respective business processes.

The AI-based delivery note scanner is designed to automate the entire goods receipt process,

minimize manual intervention, and significantly reduce the error rate for optimal traceability.

*AI-based item scanner to automate incoming goods inspection*

As part of the ongoing automation process, Rutronik is also testing an AI-based item scanner to increase the efficiency of incoming goods. Originally, the quantity check at the logistics center in Eisingen was carried out manually, mainly recording the type of article. Thanks to AI support, additional specific data can now be read and stored automatically, further optimizing and simplifying the process.



## Germany's first certified AI safety assistance system

### Background

- 6 workplace accidents per day in Germany
- Before: Capacitive assistance systems

### Solution: IFA-certified "Hand Guard" from collective mind

- Non-contact detection and tracking of hand movements & machine stop in case of risk of injury
- 100 percent reduction in accidents

- 50 checks per second
- Certified by the Institute for Occupational Safety and Health (Institut für Arbeitsschutz = IFA, DGUV)
- Implementation on edge devices
- Data quality features (ISO 25012): Fairness (deformation, skin color, jewelry, tattoos), accuracy, completeness, consistency, reliability, punctuality



The item scanner promises more accurate and efficient collection of all relevant data directly in the process.

The AI-based item scanner uses real-time images from industrial cameras to automatically detect and count items positioned under the cameras and read and store all information from the labels. Codes and text segments are detected and recorded regardless of the position of the items, making the item scanner extremely flexible and robust. The information extracted from the codes, such as item number, date code, trace code, and item quantity, is determined using parsing algorithms. This data is then fed into logistics systems.

By using this automated solution, manual intervention can be reduced to a minimum, which significantly reduces both the error rate and the time required to record and process incoming goods. The ability to automatically read and store specific item data ensures a significant increase in efficiency throughout the entire incoming goods process and enables optimized traceability to Rutronik's customers and suppliers.



Figure 3: Test operation to optimize traceability at Rutronik's logistics center in Eisingen, Germany

*AI-supported methods for feature inspection and anomaly detection*

Rutronik is already initiating further projects in the quality inspection of electronic components. This is because collective mind has an AI-based technology for feature inspection that can use cameras to inspect any point on objects for a wide range of features. Depending on the size and nature of the feature being inspected, surface damage and deviations

down to the micrometer range can be reliably detected in less than a second. collective mind's AI-based anomaly detection methods are particularly promising for product and quality inspection application scenarios. Any type of data can be used, including images, text, sensor data, and spreadsheet data. By combining and comparing the data with and among each other, the goal is to obtain as complete a picture of the component as possible. In this way, the possible degree of anomaly is determined and the anomaly is located as accurately as possible. The visual inspection of solder joints on printed circuit boards is an application scenario that lends itself well to

the use of anomaly detection using conventional camera technology.

*Comprehensive feature set for maximum flexibility with the AI Platform*

collective mind's AI Platform offers a wide range of features to take enterprise AI projects to the next level:

- Stable operation for AI applications of any type, regardless of size or complexity, which is especially critical for complex supply chains.
- Deep insights into datasets and models to analyze and optimize AI systems.
- Intuitive configuration options for all components ensure that the platform is simple and easy to use for both the internal team and external partners.
- Comprehensive monitoring and alerting systems ensure that relevant events are detected in real time and can be handled efficiently.
- Flexible scalability – from IoT sensors to individual PCs and machines to supercomputer clusters – to meet growing needs.
- Modular design that allows the platform to be extended with custom components as needed for customization.



Thomas Rudel, CEO of Rutronik

“We want to encourage them to tackle the economic upturn together by focusing on strategically considered investments and by joining forces.”



Artur Hefner, Managing Director of collective mind for the operations und finance ressorts

“We are joining forces with Rutronik with the aim of offering internationally scalable software and hardware solutions developed from a single source for AI applications in retail and industry.”

- Availability in the cloud and on-premises to ensure optimal deployment options as needed.

Take advantage of the AI Platform and contact Rutronik with your application scenario to explore the opportunities for optimization and increased efficiency through AI support.



Click here for more information and contact details



# CONNECT. EXPERIENCE. TRUH.

TRUH events create  
a genuine connection with your guests.

Individually tailored formats and  
our all-round service create unforgettable highlights  
and immersive brand experiences.

Emotionally moving events.

10 years Rutronik Automotive

# Strong network and own reference designs

*In this interview, Uwe Rahn, Senior Director Automotive Business Unit (ABU) at Rutronik, provides an insight into the milestones and highlights of Rutronik's business unit, which is specially tailored to the automotive segment. You can also find out more about the discussions currently being initiated by the ABU network on the most important future technologies in automotive electronics.*

**The Rutronik Automotive Business Unit is celebrating its 10th anniversary this year. What are your personal highlights of the past few years?**

*Uwe Rahn:* It is not easy to focus on one highlight. As a team, we have achieved many great milestones in just a few years. These include numerous automotive reference designs in recent years, such as the development and presentation of the 800 V reference design "Smart HV-eFuse" in cooperation with our partner Vishay. The latest reference design, developed especially for the Asian and ASEAN region, fo-

cuses on 48 V micromobility for light electric vehicles (LEV). The approach includes the technological areas of traction inverters with 15 kW, an on-board charger for 48 V systems, a DC/DC converter for up to 1 kW, and an e-fuse variant for the protection of 48 V on-board power supply systems. Rutronik ABU's trade fair appearances in the USA and Asia, e.g. at this year's Future Mobility Asia in Bangkok and the ASEAN Automotive Supply Chain 2024 in Thailand as well as the electronica India 2024 in Delhi and 2023 in Bangalore, were important for the presentation of the reference

design. And of course, our first Rutronik Automotive Convention in Dearborn, Michigan also provided numerous opportunities to talk to experts in our network about our reference designs.

**That sounds exciting. Can you give us some impressions of the Rutronik Automotive Convention in the USA, which took place at the beginning of October?**

The Rutronik Automotive Congress fits perfectly into our ABU event concept. As early as 2018, we organized the first Rutronik Auto-

**RUTRONIK  
AUTOMOTIVE**

**10**  
*Years*  
of success stories

**DISCOVER  
INNOVATION  
OF TOMORROW!**

Images: Rutronik





Presentation at the Rutronik Automotive Convention 2024 in Dearborn, Michigan

tive Congress in Pforzheim, in the immediate vicinity of Rutronik's headquarters. This was followed by further congresses in the following years 2019, 2022 and 2023, as well as the first Automotive Congress in Turin in 2019.

We are now expanding this event concept as Rutronik's own global congress for our automotive network. We are focusing on presentations by electronic component manufacturers, Tier 1s, and OEMs to address the latest developments and technologies in automotive electronics. Participants at our Rutronik Automotive Convention in the USA were particularly impressed by the high level of technical detail and the quality of the discussions. To illustrate Rutronik's expertise in research and development (R&D), Neal Enzenauer, Field Application Engineer at Rutronik, presented the Hybrid Energy Storage System (HESS) from Rutronik System Solutions.

**What is the secret of your success in bringing the automotive community together?**

In particular, the proximity of the Rutronik Automotive Convention to "The Battery Show" in North America, which took place in the same week in Detroit, was a strategic advantage at the Automotive Convention in October. Rutronik was also exhibiting at the trade fair, underlining its expertise in automotive electronics.

At our ABU events, we also want to offer visitors ideal opportunities for exchanging ideas and networking – in a somewhat more protected environment than at a trade fair. For

this reason, our congress events are accompanied by a trade fair at which selected manufacturers of electronic components present their latest automotive-qualified components. This networking opportunity is rounded off by evening events to get into conversation with each other in a businesslike atmosphere.

With the Rutronik Automotive Convention in the USA, but also with our Automotive Congress events in Pforzheim, we focus on an ideal mix of future-oriented presentations and a concluding panel discussion. We listen to our network and find out which topics are currently being discussed and which we will subsequently address in our event program.

**And what topics are currently at the top of the agenda?**

First of all, I would like to give you an insight into some of the highlights of our agenda at the Automotive Convention in the USA. These include presentations by Andreas Nebeling, Vice President Global Business Development at Elmos, on vehicle lighting and ADAS. Arnd Herwig, Vice President Engineering at Brose and President of the German-American Business Council of Michigan, discussed the status and technology trends of mechatronic systems in the automotive industry with the participants. Mustafa Dinc, Senior Vice President Business Development Automotive at Vishay, spoke about light electric vehicles with 48 V for use in urban areas, for which we already have reference designs. Simon Fürst, Cooperation Manager Automated Driving at BMW, took part in the concluding panel discussion on autonomous driving and provided valuable

insights into the future of automotive technology from the perspective of this German premium car manufacturer in addition to his main presentation with integrated video on ADAS Level 2 and 3.

**And what about the development of autonomous vehicles? What did the experts on the panel discuss?**

For this scenario, several aspects have to be considered: the complex interaction of different components and the safety aspect, especially – but not only – in urban areas. OEMs are currently working on the next generation of Level 4 vehicles. One example is VW with its ID code developed for China. However, it will be several years before "real" Level 5 autonomous driving becomes a reality, especial-



Uwe Rahn, Rutronik

*“As a team, we have achieved many great milestones in just a few years. These include numerous automotive reference designs.”*



Electronic component manufacturers share the latest automotive-qualified product innovations.

ly as I believe that only a few highly developed cities, such as Singapore, are currently in a position to implement the necessary infrastructure for such projects. This topic was hotly debated during the panel discussions at our Rutronik Automotive Convention in the USA and at the Rutronik Automotive Congress 2023 in Pforzheim. Time and again, the participants pointed out the business case required to establish this previously very cost-intensive technology. Today, the business model is more likely to emerge in the commercial sector, for commercial and land vehicles, shuttles, and taxis. It is not only the technology in the vehicles that needs to evolve, but also the driving culture. By this I mean above all the acceptance of the coexistence of man and machine in freight and road transport.

**In addition to the topic of autonomous driving, you mentioned a whole range of topics that are addressed in presentations at your ABU events. What are the main trends for the next five years?**

From my observations, three main areas are emerging. First, there are new technologies in the areas of light and vision for optimal interaction between different electronic components. This is a highly complex overall system that allows the combination of various elements that go far beyond flexible lighting and partial control of light output. For example, warning messages can be projected onto the road using the latest micro-LED technology.

All this offers real added value in terms of safety. Of course, the emotional properties of light are also increasingly coming to the fore. Car manufacturers are using animations and a special light signature for an optimal driving experience. This applies particularly to customers in the Asian markets.

Another interesting approach is the merging of the lighting market with the growing interest in LiDAR sensors for automated driving. The compact LiDAR sensors of the coming vehicle generations will then be integrated into corner lighting and the roof area to cover an even larger sensor field.

Secondly, in addition to the topic of electromobility, I am impressed by the rapid development of power electronics in connection with electromobility. New technologies based on silicon carbide (SiC) and, in the future, gallium nitride (GaN) enable higher power densities, higher efficiencies due to shorter switching times, lower switching losses, and therefore less heating of the component. In the case of the new SiC trench MOSFETs, voltage levels of up to 2000 V will be possible in the future.

Electrification and the use of high-voltage vehicle electrical systems make it essential to be able to disconnect components in the vehicle electrical system quickly and safely from the high-voltage battery in the event of a malfunction or accident. Alternatives to mechan-

ical solutions are increasingly in demand, for example to maintain battery life, protect consumers at other voltage levels, and ensure occupant safety. I see this as a third trend, for which we have developed a concept together with Vishay and presented it for the first time to a broad trade audience in 2022. Several demonstrators of the HV switch are now being tested by various well-known Tier 1 and OEM customers in their high-voltage research laboratories. We at ABU are particularly proud of this, as we are considered to be one of the pioneers of these new HV topologies. The response has been good, and we have found that semiconductor-based HV switches are currently being considered or evaluated by many market players for the next generation of vehicles. Our proof of concept shows developers which components and circuits can be used to realize certain functions within an HV eFuse. We will provide the complete documentation, i.e. topology and BOM, free of charge in order to shorten the time-to-market for our interested customers' in-house developments. ■



Here are more insights into 10 years of ABU



Neuronal processing units from edge use to data center

# Fit for the AI age

*The range of AI development tools is diverse and continuously expanding. This article offers an overview of powerful AI-enabled tools – ranging from chips and processors to boards and computers.*

BY BERND HANTSCH,  
VICE PRESIDENT PRODUCT MARKETING  
EMBEDDED & WIRELESS AT RUTRONIK

It feels as though our world is spinning faster and faster – and the innovation cycles of the electronics industry are getting shorter and shorter. In the more than 50 years since its foundation, Rutronik has consistently kept pace with industry developments, thereby providing its customers with access to the latest innovations. In the current landscape of artificial intelligence (AI), hardware with AI accelerators, such as neural processing units, can now be found across all product areas and performance classes. These accelerators function as coprocessors, ensuring applications,

from field use to data centers, are fit to meet future requirements. Further, there are various legal aspects that companies need to be aware of.

## *The end of Windows 10 and the consequences*

Many companies still have notebooks running the Windows 10 operating system. However, Microsoft has already announced the official end of support on October 14, 2025. And it is



Image: sysiphus/stock.adobe.com

A bit more foresight and a time buffer help to avoid a depleted market and to achieve better purchasing conditions before the shelves of distributors and retailers are empty.



## BD28C5 – New family of PWM controller ICs for “Flyback” based auxiliary power supply applications

- Product line up with **different UVLO levels** to address both Si (MOS/IGBT) and SiC MOSFETs
- **Pin to pin compatible** to products available in the market
- **PWM Current mode control**



INDUSTRIAL  
DRIVES



OFF-BOARD  
CHARGER



ENERGY  
CONVERSION



PSU



Image: Extra Computer

Figure 1: With the exone go Business 1490 X14 and exone go Business 1690 X14 notebooks, Rutronik provides two models featuring a 14" and 16" display, both powered by the new AI-capable Intel Core Ultra 7-155U processor.

not just technical support that is on its way out. The lack of security updates in particular is forcing companies in environments with increased criticality to make a transition due to the Network and Information Security Directive (NIS2), which is set to come into effect a year earlier (October 2024). That said, all other businesses, as well as private users, should also be aware of future security risks, especially as potential threats are bound to increase.

Users who simply want to update their existing computer environment to Windows 11 might fail due to a lack of compatibility or increased system requirements. Owners of computers with Intel Core processors up to and including the seventh generation would, at best, need to switch to Linux or operate offline to avoid a disaster. Most companies and users will likely see the end of support as an opportunity to upgrade their hardware when transitioning to Windows 11. Additionally, the peripherals in the latest devices have also advanced. Users also benefit from newer Bluetooth and Wi-Fi specifications, as well as enhanced cameras, displays, and battery life. When purchasing new computers as part of the transition to Windows 11, it is advisable to choose devices with an integrated NPU. This not only relieves the CPU and GPU but also provides enormous speed and energy management benefits for the ever-increasing use of AI processes.

### Expert advice and individual configuration options

With the exone go Business 1490 X14 and exone go Business 1690 X14 notebooks, Rutronik provides its customers with two models featuring a 14" and 16" display, both powered by the new AI-capable Intel Core UI-



Image: Intel

Figure 2: The Intel Core Ultra processor family offers advanced AI functions

tra 7-155U processor. In a durable and lightweight housing (overall weight approx. 1 kg), security functions ensure data protection. Advanced connectivity options ensure that a connection can be established with the computer anytime, anywhere. The supplier stipulates a battery life of 16 hours, thus guaranteeing that even after years of use, there should still be enough power for a whole working day (Fig. 1).

The experts from the relatively new Rutronik IT Electronics division offer advice on configuration options, expansions, peripherals, and AI accelerator cards for existing hardware, for example. The team is also happy to assist with the individual configuration of a computer. As an official Intel franchise distributor, Rutronik provides the new Core Ultra processors together with compatible motherboards from Kontron, Asus, and Advantech. Along with a portfolio of main memories, ROMs (also in conjunction with Windows licenses), power packs, housings, and peripherals, it is possible to assemble customized AI computers.

### A look at the computer market

Looking beyond the present and into the future: When the COVID-19 pandemic struck and many people started working from home, all things computer-related experienced a boom in popularity. Laptops and peripherals were acquired for the now mobile workforce, along with servers that facilitated networked, decentralized working. The supply chain was put to a hard test. Many semiconductor components were allocated to the computer industry, which obviously had the added advantage of placing large orders. For every car produced, there were countless new laptops manufactured. Some sectors, like the aforesaid automotive industry, were left trailing when it came to chip supplies. They sought to acquire the coveted resources on the market by means of increased forecasts and placing double orders, thus aiming to broadly maintain the production levels of their end products. When the market stabilized in 2022/2023, storage facilities were suddenly overwhelmed with backlogged orders. Even in 2024, stock

coverage of up to two years can still be observed, which is arguably a historical record.

Due to the full storage facilities of electronics processing companies and a weakening economy, new orders are scarce, as delivery times and semiconductor availability are no longer critical concerns. Caution is advised: Semiconductor suppliers are being forced to scale back their production capacities and to adjust their supply chains accordingly.

This yo-yoing of store inventory and production volumes has been known colloquially for decades as the hog cycle. Despite the dramatic fluctuations in recent years, the current situation is quite different from the familiar patterns of the past. The uncertain economic climate, marked by interest rates higher than those of the past decade, is causing companies to be more cautious about investing, with hopes that interest rates will soon start to fall. The end of support for Windows 10 and the competitive pressure to use AI are set to give the computer market a new boost in 2025. By then, the laptops from the early days of the pandemic will have been fully depreciated and can be replaced. This anticipated boom, coupled with a decrease in the production capacity for small electronic components, signals the onset of the next phase of allocation. The entire electronics industry has been emphasizing for several weeks now that long-term demand plans from customers are essential to secure supply for 2025 and beyond. All IT buyers are well advised not to wait until Microsoft's support ends. A bit more foresight and a time buffer can help avoid a depleted market and provide better purchasing conditions than waiting around until the shelves of distributors and retailers are empty again.

*Powerful AI applications and developer tools*

AI is, however, not just a topic for those of us sitting in front of a PC. Even in professional applications, such as those observed in industry, medicine, robotics, and automation, sensor patterns, camera images, and audio sources are frequently analyzed using large language models (LLMs) or large action models (LAMs), with conclusions drawn according to the laws of probability.

Let us start with sensors and actuators – in other words, very close to the workpiece. Sensor data are analyzed and evaluated for patterns before proceeding with further processing. Edge Impulse, for example, provides

machine learning software for microcontrollers from Nordic Semiconductor and Infineon. Some smart rings that monitor a wearer's health parameters and transmit the data to a smartphone utilize low-power hardware from Nordic Semiconductor, along with respective ML/AI software from Edge Impulse. The fact that a ring equipped with sensors, Bluetooth, and AI calculations runs on a compact battery highlights the significant advancements in energy efficiency achieved in recent years.

The new nRF54L and nRF54H families, which represent the latest and enhanced generations of multicore microcontrollers in a pin-sized chip, are set to be released at the end of 2024 and the beginning of 2025 respectively. With the PSoC 63 Bluetooth microcontroller from Infineon, customers can choose between Edge Impulse and the Igemob software, which is now integrated into Infineon's offerings.



Figure 3: Advantech's MIC-735E-IO AI system based on NVIDIA IGX Orin for low latency, network security, and functional safety



Figure 4: Advantech's ICAM-520 is an industrial AI camera equipped with an NVIDIA Jetson Xavier NX processing module and an industrial-grade Sony image sensor.

**Display Solutions**  
1.44" ~ 23.8"



**Embedded Solutions**  
MPU, MCU

SOM



SMARC



**i.MX8MM NXP**  
**RK3568 Rockchip**





Image: Advantech

Figure 5: Advantech's AIR-030 AI inference system based on NVIDIA Jetson AGX Orin



Image: Seco

Figure 6: Seco's fanless embedded computer Titan 300 TGL-UP3 with 11th generation Intel Core and Intel Celeron SoCs as well as Axeler AI chip

Both software solutions focus on machine learning tasks in the controller. Iimagemob is already available in the Infineon SDK Modbus Toolbox. Installation instructions for use of the third-party supplier software Edge Impulse can also be found there.

### Meeting the challenges of edge computing

If you require more processing power beyond evaluating movements, assigning sound patterns to events, consolidating environmental parameters, and making forecasts, Rutronik provides complete computers, semiconductor chips, and AI-capable embedded boards. This class is typically used for edge computing applications – in other words, a few meters away from the workpiece. Edge computing applications are powered by fixed voltages, thereby allowing them to convert more energy than battery-powered applications. The

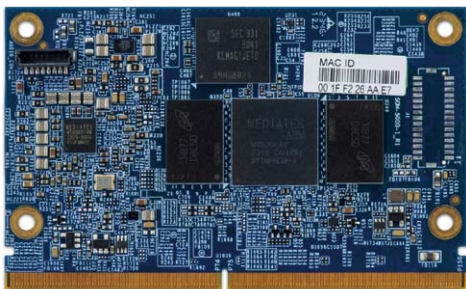

Image: Via Technologies

Figure 7: The VIA SOM-5000 module is powered by a MediaTek Genio 700 octa-core processor with an integrated AI processor that delivers up to four TOPS for deep learning, neural network acceleration, computer vision applications, and HiFi 5 audio processing.

processing power is correspondingly higher, enabling video analyses and high-frequency, often real-time calculations to be performed here.

The Intel Tiber Development Cloud offers developers access to numerous AI tools, such as OpenVino, OneAPI, PyTorch, TensorFlow, Llama2, and many other LLMs, frameworks, and toolkits. It is possible to design your own computer as a hardware platform, with Rutronik providing support for AI coprocessors using Intel Core Ultra processors (Fig. 2) or Intel Gaudi. Alternatively, a board from a third-party supplier that installed, verified, and certified the semiconductor chips can be used.

### Edge systems for processing large amounts of data

Advantech AIR-030 is the next stage of expansion and represents a fully assembled AI computer for edge use. Based on Nvidia Jetson AGX Orin, the computer offers heavy industry certification pursuant to ISO 61000-6-4 as well as USB-C, CanBus, Ethernet, and various expansion options, e.g. using M.2 cards. In addition to this computer, Advantech provides 12 further edge systems – based on Nvidia Jetson Nano, TX2 NX, AGX Xavier, or Nvidia Jetson Xavier NX. The data prefiltered in this manner correspond to only a fraction of the volume of the raw data generated by the sensors. In many cases, data transport to data centers is much less expensive and faster. For certain applications, AI calculations require processing data from various global sources, meaning that data centers will remain essential and continue to grow despite the expansion of edge computing. With the MIC-735 series, Advantech is offering complete servers based on the Nvidia IGX Origin that enable fast calculations of up to 275 TOPS (Fig. 3). An Nvidia RTX A6000 additionally powers the server family for complex moving image analyses. With the MIC-71xx family from Advantech, Rutronik provides its customers with six development environments based on various Nvidia Jetson chips for customer-specific device development.

### AI chips and boards for smart cameras

The ICAM-500, 520 and 540 models from Advantech clearly demonstrate what a camera can achieve when AI chips from Nvidia are combined with image sensors from Sony

(Fig. 4). Up to 8 MP@50 fps or 1.6 MP@60 fps enable high-resolution video signals even with rapidly changing images. The camera recognizes and evaluates the filmed scenarios within its housing so that only the conclusions from the scene need to be transferred to the externally connected computer, thereby requiring less external processing power. AI cameras from Advantech complement Rutronik's lineup of smart cameras, which have achieved significant market penetration in recent years due to the success of Intel RealSense cameras, camera modules, and chip solutions. Particularly due to the support offered by OpenVino and other AI software tools, Intel RealSense products also facilitate image analysis without excessively overloading the CPU. Adlink is another provider of AI cameras in the Rutronik portfolio, and its combination with Edge Vision Analytics software is equally interesting for a wide range of tasks.

When looking for edge computing systems to operate in particularly harsh environments, it is worth considering the Advantech MIC-71x family or the MIC-730IVA. This type of computer can capture and analyze up to eight video streams – even without a fan, which is crucial for use in dusty environments, for instance. The performance range spans from 512 GOPS to 21 and 32 TOPS, all the way up to 100 TOPS for the high-end MIC-7150X and MIC-7170X models. SECeDGE software on the Advantech computers protects the customer's AI models, ensures data integrity, eliminates the need for an external TPM chip, and, at the same time, enables secure boot, firmware updates, failure recovery, encryption, credentials management, and cloud integration (Fig. 5).

### Computer, processor, and boards for AI applications

An AI solution from the Italian PCB supplier Seco is the ideal choice for certain applications. Seco Titan 300 TGL-UP3 AI is a fanless multicore computer that utilizes Intel Core and Intel Celeron processors, allowing tasks to be performed on the most energy-efficient processing units (Fig. 6). Moreover, Seco has added an NPU as a coprocessor to the two CPUs. An Axeler Metis, also referred to as an AIPU (artificial intelligence processing unit), can deliver up to 120 TOPS. Via Technologies, Rutronik's relatively new franchise partner, utilizes intelligent semiconductors from MediaTek for its AI boards. Via ARTiGO A5000 is an ultra-compact and fanless ARM system with eight performance cores (two MediaTek

Image: Advantech

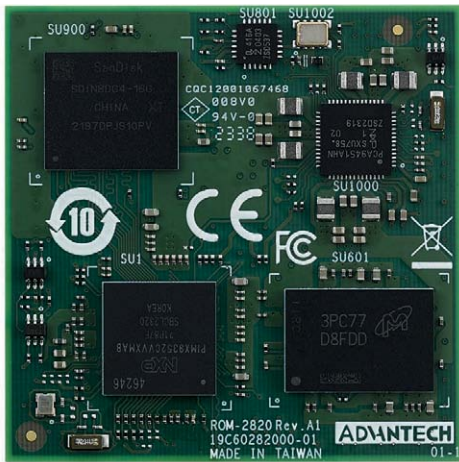

Figure 8: Advantech's ROM-2820 is a powerful SoC (OSM size L) with Edge ML capabilities

Genio 700 or two ARM Cortex-A78 units) for AI applications on the edge. Two AHD cameras can also be connected to Via SOM-5000 using MIPI and touch panels using LVDS and HDMI (Fig. 7). The 4K hardware acceleration supporting H.265/H.264 enables video compression and decompression without placing any additional load on the main computer. The four TOPS of the AI unit should be adequate for many video tasks, allowing for savings in

both energy consumption and acquisition costs from the product selection stage onward.

For retrofitting existing workstations or servers with AI accelerators, the iEi Mustang-T100-T5 and Mustang-M2BM offer corresponding expansion cards. The T100 card utilizes five Coral Edge TPUs from Google, while the M2BM card performs calculations using two Intel Movidius Myriad X VPUs. The Google card already delivers 20 TOPS while consuming only about 15 W. Alongside iEi, Molex's sister company, BittWare, also utilizes Intel technology with its IA-440i accelerator card. However, it uses an Agilex 7 FPGA chip from Altera, launched as a stand-alone FPGA company by Intel. The card is ideal for high-speed data storage tasks, making it well-suited for use in data loggers and the construction of storage servers.

*Modular solutions for computationally intensive applications*

AI has also made its way into the ever-popular segment of standardized open standard

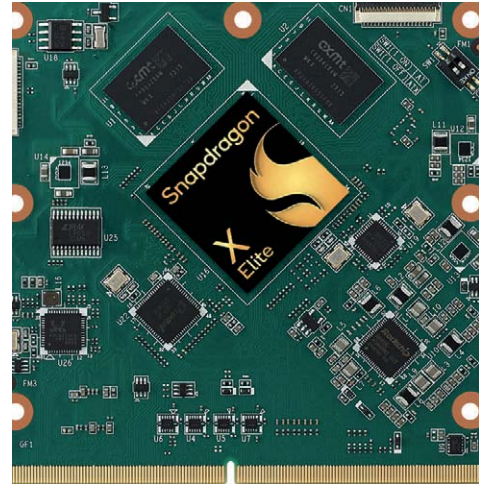

Image: Advantech

Figure 9: Advantech's AOM-7721 is powered by a Qualcomm X Elite SoC for machine image processing and AI applications

modules (OSM). With Advantech ROM-2620, ROM-2820, and ROM-2860, Rutronik offers three modules that are also referred to by the supplier as power saver, AI enabler, and transboundary star – providing tailored solutions for field calculations based on specific requirements. While the first two modules operate on the Yocto operating system, the

Advertisement



The DNA of tech.®

# Behind the power is The DNA of tech.®

One of the world's largest portfolios of discrete semiconductors and passive electronic components essential to your designs

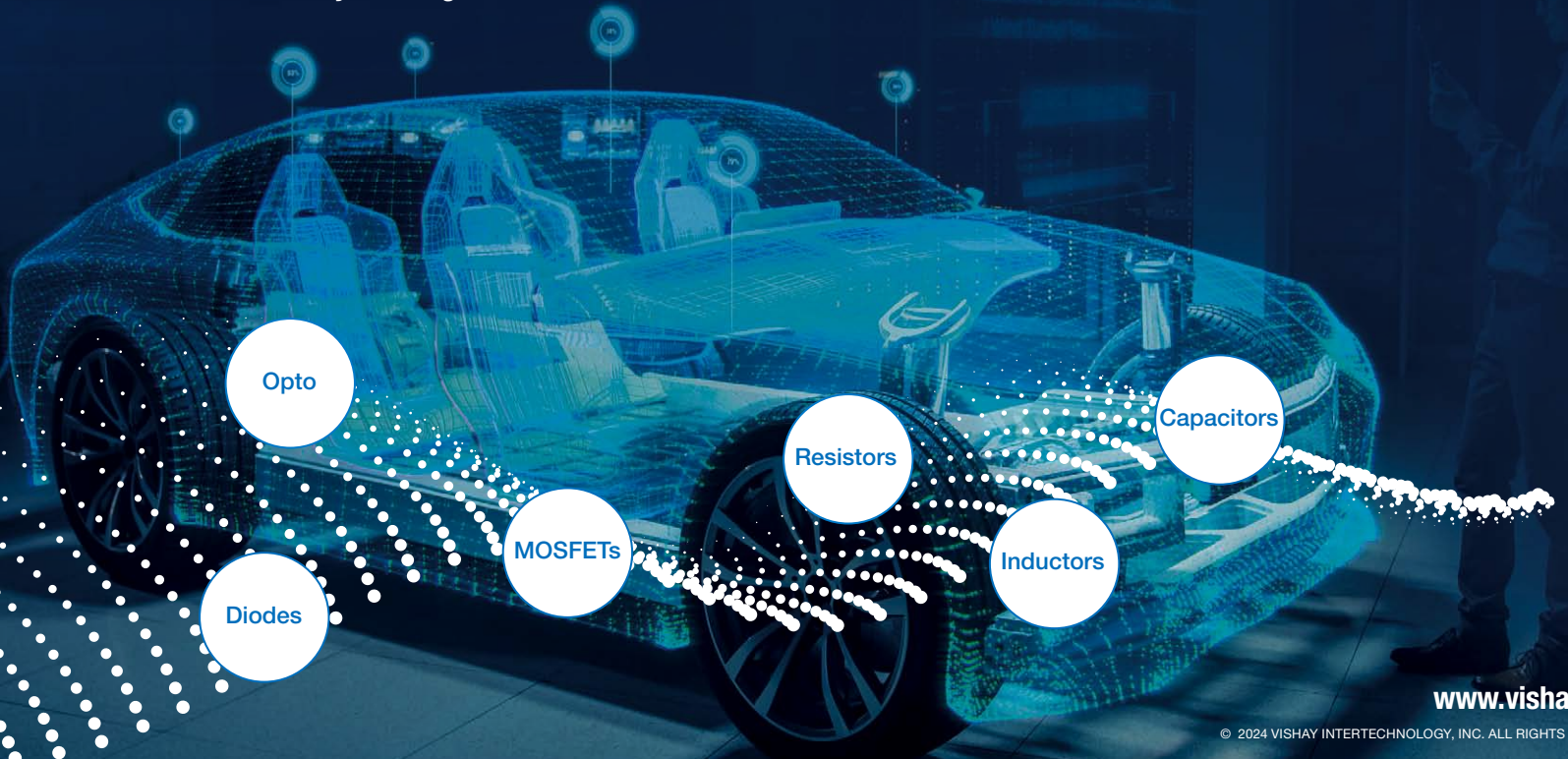

www.vishay.com

© 2024 VISHAY INTERTECHNOLOGY, INC. ALL RIGHTS RESERVED.



last variant is available exclusively for Windows 11 on ARM or Ubuntu. All three OSM modules are guaranteed to be available until 2034, ensuring that today's investment in development has ample time to yield a return on investment. The Yocto modules support ARM Cortex-A35 or A55 cores. The ROM-2820 can access a 500 GOPS Ethos-U65 NPU, which can execute AI algorithms up to ten times faster than the Cortex-A55 core (Fig. 8). The flagship ROM-2860 is based on a Qualcomm QCS6490, which contains the Kryo 670 CPU and the Hexagon NPU from the same company. The processing power is often used in dash cams, lawn mowers, vacuum cleaners, or industrial scanners for ultrafast camera analysis – the 12 TOPS make this possible. With ARM64 compatibility and integrated Wi-Fi 6E, prefiltered data can be seamlessly transmitted to Microsoft Azure Cloud or leveraged with Azure AI Services,

along with an extensive range of other development tools.

Even larger form factors, such as computer-on-modules, have long been available from Rutronik with integrated AI. The Advantech AOM-3511, with five TOPS, is just 5 cm deep, whereas the AOM-3411 has a depth of 80 mm. The former is based on an ARM Cortex Multicore. Six A55@2 GHz, one M7@800 MHz and one M33@250 MHz allow tasks to be addressed by the most appropriate processing unit. The AOM-3411 goes a step further: Powered by a Rockchip RK3576, four A72@2.2 GHz, four A53@1.8 GHz and one M0@800 MHz are available here. The integrated NPU performs up to six TOPS.

The variety of microcontroller architectures and the operating systems available can still be somewhat overwhelming for newcomers,

those transitioning, or those returning to the industry. In June 2024, the first laptops utilizing ARM architectures rather than x86 were introduced, featuring Microsoft Windows 11 on ARM in the substructure and Microsoft Copilot in the superstructure. All laptop suppliers, including Microsoft with its Surface models, rely on the new Qualcomm Snapdragon X Elite processor as the drive unit. This new processor is also already used in the AOM-7721 computer-on-module from Advantech (Fig. 9). With a mighty impressive 45 TOPS, AI performance in end devices now rivals what was once only achievable in energy-intensive servers. The Advantech RSB-3810 is a single-board computer in the 2.5" Pico-ITX form factor, ideal for those who are unable to use a baseboard for computer-on-modules. The computer is powered by a MediaTek Genio 1200, which contains a CPU, VPU, and MDLA, and is, therefore, also suitable for more computationally

Linux-based operating system for the critical infrastructure use of embedded devices

## Tailor-made and secure

*In a progressively interconnected world where cyber threats are ever-present, companies are increasingly challenged to protect their systems and data from cyberattacks. KontronOS is an operating system for IoT security.*

BY JOHANNES GASDE, CORPORATE PRODUCT MANAGER EMBEDDED & WIRELESS AT RUTRONIK, JENNIFER LACHKY-BUSCH, PORTFOLIO MANAGER IoT SOFTWARE AT KONTRON AIS, AND MARC ROEDER, CUSTOMER PROGRAM MANAGER AT KONTRON AIS

The breakthrough and increasing prevalence of the Internet of Things (IoT) mean that IoT applications are managing more and more highly sensitive data and processes, prompting a stricter legal framework. The changed requirements will be taken into account in Europe in 2024 by adapting the Radio Equipment Directive and the Network and Information Security Act (NIS2). The EU RCE directive focuses on the resilience and physical security of critical infrastructures, and member states are required to implement appropriate measures by October 2024 at the latest. Suppliers, integrators, and operators of IoT products in the critical infrastructure environment must meet comprehensive requirements in the IT security sector. This issue particularly affects suppliers and customers in the Rutronik Embedded sector.



Fig. 1: KBox-A-151 with 3.5"-SBC-AML/ADN (left), AL i.MX8M Mini Box PC, and SMARC-sXEL E2 module



intensive operations, especially those based on TensorFlow Lite.

*Product overview in the new  
Rutronik AI Highlights brochure*

If this overview of our product categories, ranging from compact AI microcontrollers to robust AI servers, has piqued your interest in the full spectrum of performance, the Rutronik AI Highlights brochure provides an informative comparison. It also includes products from DFI, AAEON, Cherry Embedded Solutions, Adlink, and specialized storage solutions from various suppliers. With this topic in particular, it is worth noting that as the world continues to spin faster and faster, Rutronik is expanding its product range with new AI solutions almost every day. As such, a chat with the experts at Rutronik cannot be replaced by AI or

the catalog. Please do not wait until the official end of support for Windows 10, as prices and delivery times are likely to increase once again.

Get in touch with us through your assigned and trusted sales contact, or email us at [embedded@rutronik.com](mailto:embedded@rutronik.com).



Scan the QR code for more information and to contact Rutronik IT Electronics

Take a direct look at the AI Highlights brochure

To satisfy these demands, Kontron has developed a secure, hardened Linux-based operating system. By integrating KontronOS, the edge devices AL i.MX8M Mini Box PC, KBox-A-151 with 3.5" SBC-EKL and 3.5" SBC-AML/ADN, or the SMARC-sXEL E2 module (Fig. 1), for example, become a secure platform against cyberthreats. The boxes offer high processing power and reliability for demanding applications in areas like industrial automation, transportation, and medical technology.

The core element is the same for all customers. However, the software has been customized to offer customers a wide range of configuration options to meet individual needs. The Yocto build environment enables you to include only the components you really need in the system while excluding all the unnecessary ones. This significantly reduces the number of software components that could potentially contain errors. For instance, the kernel is configured to include only the minimum necessary components. This approach

allows you to focus on the application or your existing Docker container.

*Docker container and secure boot  
for greater security*

An application example: a supplier of sawing machines monitors the status of their production using a self-developed algorithm that is encapsulated in a separate Docker container. This tracking enables the company to in-

Advertisement

# Who we are



SAURO is an Italian company that for 40 years has been excelling in the supply of electromechanical products, such as connectors and terminal blocks for printed circuit boards. Our mission is to offer a safe, reliable and innovative product, whose entire production chain, from supplier selection to packaging, must respect and protect the environment and people through choices that focus on excellence. We are present in the world main markets with sales offices and warehouses for on-site service; in particular, our branches are located in Krefeld (Germany), Austin (USA) and Shanghai (China).

# What we do

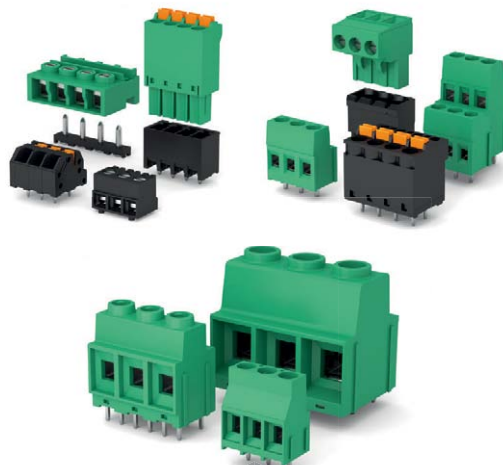

# What Can we do for you?

**Design-in**

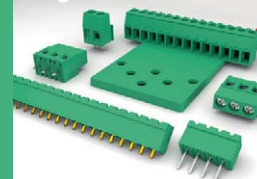

**Colors & marking**



**Packaging in kit**



**Products for automation**



[www.sauro.net](http://www.sauro.net)

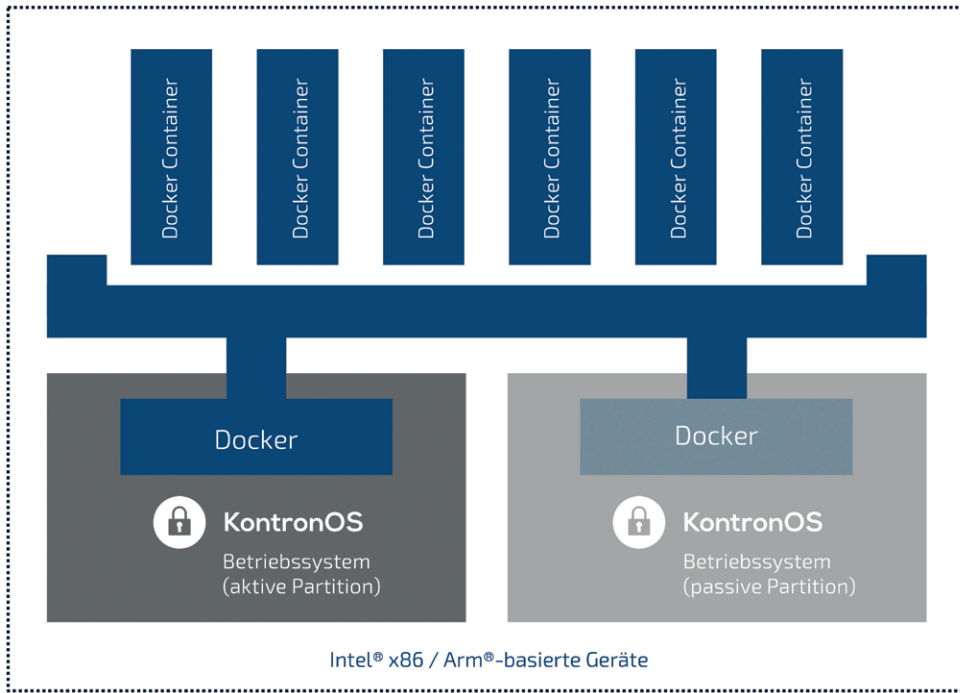

Fig. 2: Standard IoT stack with pre-installed secure KontronOS operating system

crease the production capacity of its saws and improve service for its customers. The use of KontronOS permanently ensures that the IoT-enabled device on which the algorithm is located can be operated securely. The specific configuration of the operating system is adapted entirely to the existing preconditions (e.g. modified interfaces (IO), modified package, BIOS modifications, or secure boot). Various integration levels and the containerization of the software ensure that the interaction between the operating system and the customer application functions smoothly in every possible setting.

Thanks to this customization, the supplier's other applications can also be executed on the basis of KontronOS from this point onward – and benefit from its security and the advantage that the application level and the operating system level operate separately from each other.

If, for example, a new operating system update is installed, the switch is simply flipped to another partition. Docker, with its containerized approach, enables smooth transitions and ensures that the applications remain intact and operational. The key to this is that Docker keeps the applications in a separate environment. There is, therefore, no need to regularly change system settings or run the risk of losing files during updates. In addition, Docker containers offer an alternative to traditional application installation. They can be easily moved from one device to another, simplifying the deployment process.

Secure boot (or HAB) can be used to ensure that only approved software is loaded. The root file system (RootFS) is write-protected and, as a result, cannot be altered. The delivery status can be restored at any time. Customer applications can also only be loaded onto the system once they have been verified. This ensures that only the approved software operates on the device. All the system components can be updated: bootloader, operating system, or customer application, including Docker container. This can be achieved online or offline – for example via a storage medium such as a USB flash drive or an internal update server.

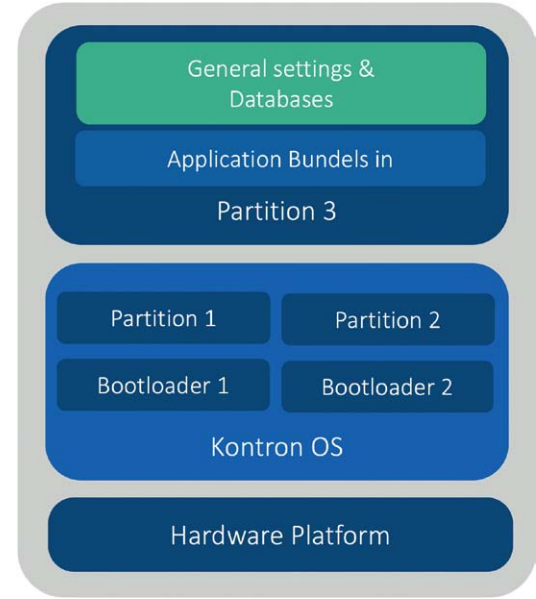

Fig. 3: Main features of KontronOS based on Yocto Linux: full integration of the board support package, hardened operating system for ARM and x86, two redundant OS partitions for 100 percent operating time

The devices can be simply managed via the KontronGrid device management system. Service technicians are assisted by a configuration interface for start-up and remote access, thereby facilitating fleet updates. Automated tests, a test, and a test report ensure product quality, and system security is regularly checked through penetration tests. Customers utilize IoT devices to drive forward their digitalization, and Kontron supports them in collecting and analyzing device data. Moreover, key performance indicators (KPIs) or alarms can be determined to monitor production capacities and detect service cases at an early stage.



## Special features of KontronOS

Two redundant Yocto Linux partitions (active and passive) provide redundancy and enable automatic rollback to previous versions should issues arise during the update process

Regular security updates and penetration tests

Secure boot/HAB available, only approved software can be installed

Updating the bootloader, the operating system and the customer applications (online and offline)

Automatically configured DNS table-based firewall

A distinct separation between the operating system and the application levels allows customer applications and Docker containers to operate independently of each other



RDK4 is the door opener in automotive pre-development and rapid prototyping

# Precise functions of electronic door handles

*Minebea, a leading player in the automotive sector, has partnered with Rutronik System Solutions in its pre-development phase of electronic door handle functionalities. More specifically, the automotive-qualified Rutronik Development Kit RDK4 was a door opener here in the early testing of electronic components for several functions of the next generation of automotive door openers.*

BY ANDREAS MANGLER,  
DIRECTOR STRATEGIC MARKETING  
AT RUTRONIK

**M**inebea, a pioneer in the automotive industry, has been at the forefront of electronic door handle technology for more than three decades. In Minebea's Access Solution Segment, they focus on automotive components (door latches, door handles, door mirrors, etc.), wireless communication devices, and industrial machinery components. When it comes to door handles, their expertise extends to the development and production of innovative features such as antennas, sensors, strain gauges, and motors. Door handles have also been developed as a Minebea Mitsumi Group's integration product, which include antennas, sensors, strain gauges, motors, and other technologies. Collaborating

with U-Shin engineers, Minebea focuses not only on aesthetics but also on additional functionalities. Optional features include welcome lights, touch sensors, LF antennas, and inertial lock mechanisms to prevent door opening upon impact in collision events.

The Base Board RDK4 has been proving a door-opening function in the Minebea project in many ways. First of all, it is the first applied project of a customer whose highlights are revealed now. The project demonstrates the door-opening function that the RDK4 can perform in the pre-development of automotive applications. Specifically, this is an OEM project with Minebea. The application is an elec-

Images: Rutronik



Example application of the Rutronik Development Kit RDK4 for testing applications in the automotive cockpit

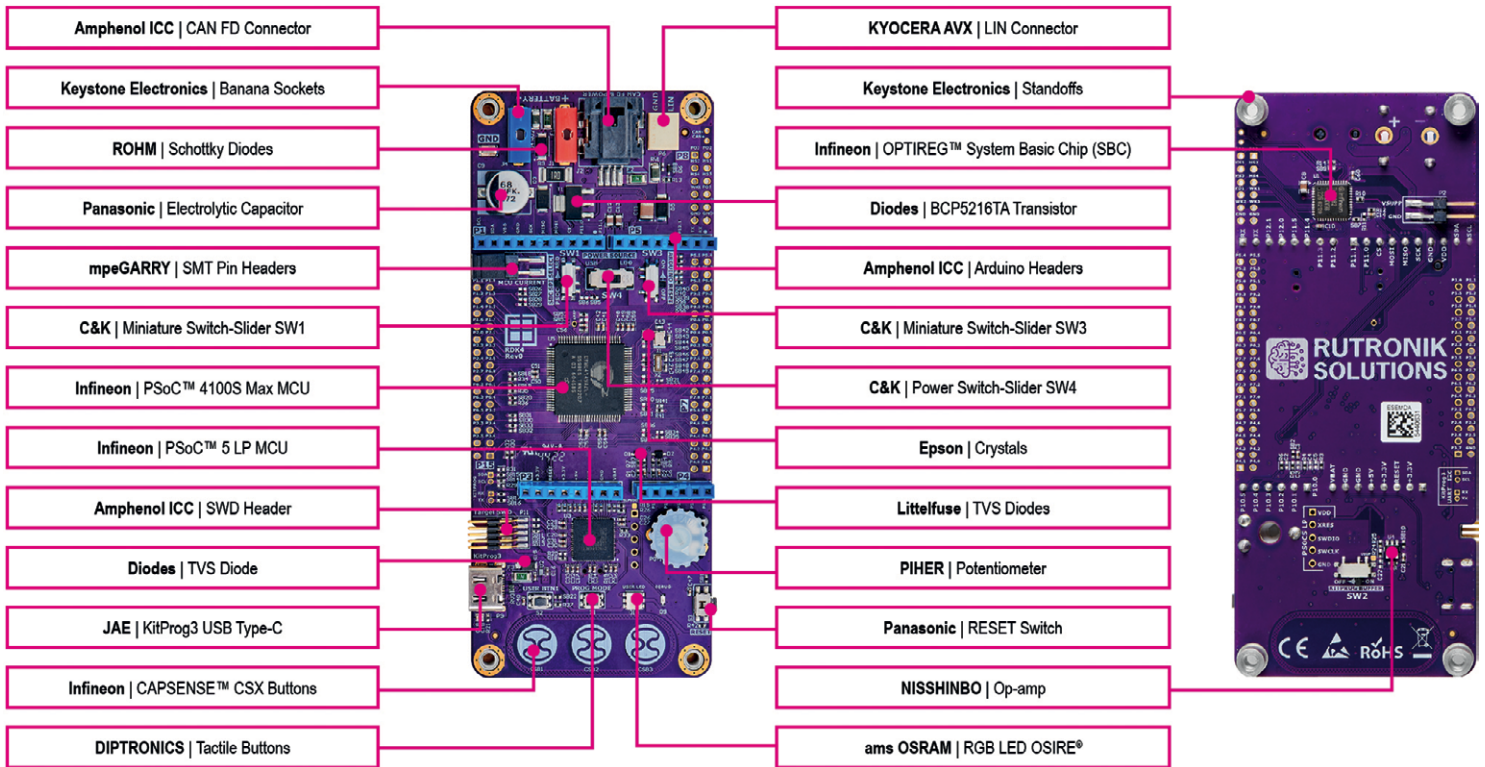

The Base Board RDK4 from Rutronik System Solutions combines cutting-edge components to shorten the pre-development phase.

tronic door handle and it was particularly important for Minebea to test and implement the basic functionalities.

The Base Board RDK4, available in the market for one year, specifically caters to OEMs and Tier-1 suppliers in the automotive industry. It provides a compact solution for motor control units, enabling efficient and rapid development of applications. By freeing up resources, developers can focus on the next stages of mobility evolution and actively compete on a global scale.

Technical details of the RDK4 at a glance:

- The RDK4 is based on the Infineon PSoC 4100S Max microcontroller, which is automotive-certified.
- It also includes a System Basis Chip (SBC) and essential automotive interfaces such as CAN-FD and LIN.
- The board's unique advantage lies in its integration of diverse components for motor control development.

Developers can thoroughly test and evaluate different components, including controllers, sensors, CAN-FD, LIN, etc. to identify the best fit for their specific application and the corresponding functions. By significantly reducing the time for pre-development, which typically involves ordering and assembling hardware components, OEM and Tier-1 developers gain a substantial time advantage. The RDK4 streamlines feasibility analyses and accelerates innovation.

The development timeline for a board is part of the pre-development phase and depends on various factors, making a generalized cost-benefit analysis challenging. In the case of the RDK4, Rutronik estimates this timeline:

- Hardware design development: Approximately two months
- Final testing phase for integrated components: Nearly one month
- Additional time for component delivery due to supply chain challenges

Overall, around three months of work, plus component delivery times, were necessary to complete the new design. Notably, the personnel costs of approximately €20,000 compare favorably to the RDK4's acquisition price of approximately €100 (based on information from Stepstone on the average salary of a hardware developer with average experience).



## About Rutronik System Solutions

Rutronik System Solutions established its presence to support firmware and hardware developers during the pre-development phase. The goal is to accelerate innovation processes and the market introduction of new applications. With the realization of the RDK4, there is a focus product for the automotive industry and its challenges on the path to sustainable mobility. Optimization also means that OEMs and Tier-1 suppliers have a partner in Rutronik with respect to expertise in both hardware and software development, willingly shares knowledge, and provides access to cutting-edge, automotive-certified components.

"We observe that the development teams of our customers are starting with test cycles in mind for a specific function of their application," emphasizes Stephan Menze. "They then move on to other versions of the component to explore additional application features using our boards," he concludes. Thanks to the Arduino interface of all Base and Adapter Boards, they can be easily combined with one another. This modular concept opens up even more development approaches that can be implemented quickly, cost-effectively, and simply, yet in a technically sophisticated way.

Front view of the Base Board RDK4  
from Rutronik System Solutions

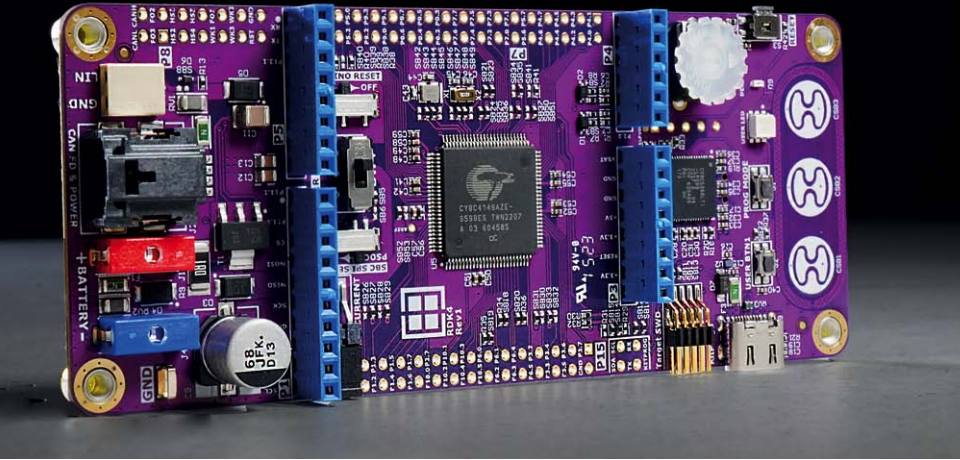

The RDK4 proved invaluable for Minebea, allowing them to save one to two months by leveraging the RDK4. This time-saving advantage was particularly crucial given their tight schedule.

Dr. Sebastian Rettenberger, Software Team Leader at Minebea AccessSolutions Germany,

says: "The RDK4 was a great help, as we saved one to two months' time by using the Development Kit. This was very valuable for Minebea, especially given the very tight schedule."

This feedback is music to the ears of the developers and field service engineers in the Rutronik System Solutions R&D department

founded five years ago and headed by Stephan Menze. The focus across all Base and Adapter Boards of Rutronik System Solutions is on reducing time to market to proactively support customers. The RDK4's precise evaluation of the functions that are essential for door handles proves that the modular board concept, which combines various components, makes all the difference.

Stephan Menze, Head of Global Innovation Management at Rutronik, confirms: "We prioritize versatility, ensuring that our boards cover a wide range of components to enable developers to test the features and functions of different applications, in line with our broadliner approach." ■



Scan the QR code to  
watch the RDK4 video

Advertisement



## MA01 SERIES FLOATING BOARD-TO-BOARD CONNECTORS

- Floating tolerance:  $\pm 0.5$  mm in both X & Y directions
- Stacking height tolerance between boards:  $\pm 0.5$  mm in Z-axis direction
- Two-point contact structure ensures high contact reliability
- Operating temperature range:  $-40^{\circ}\text{C}$  to  $+125^{\circ}\text{C}$
- 8 Gbps+ high-speed transmission
- Supports automatic mounting

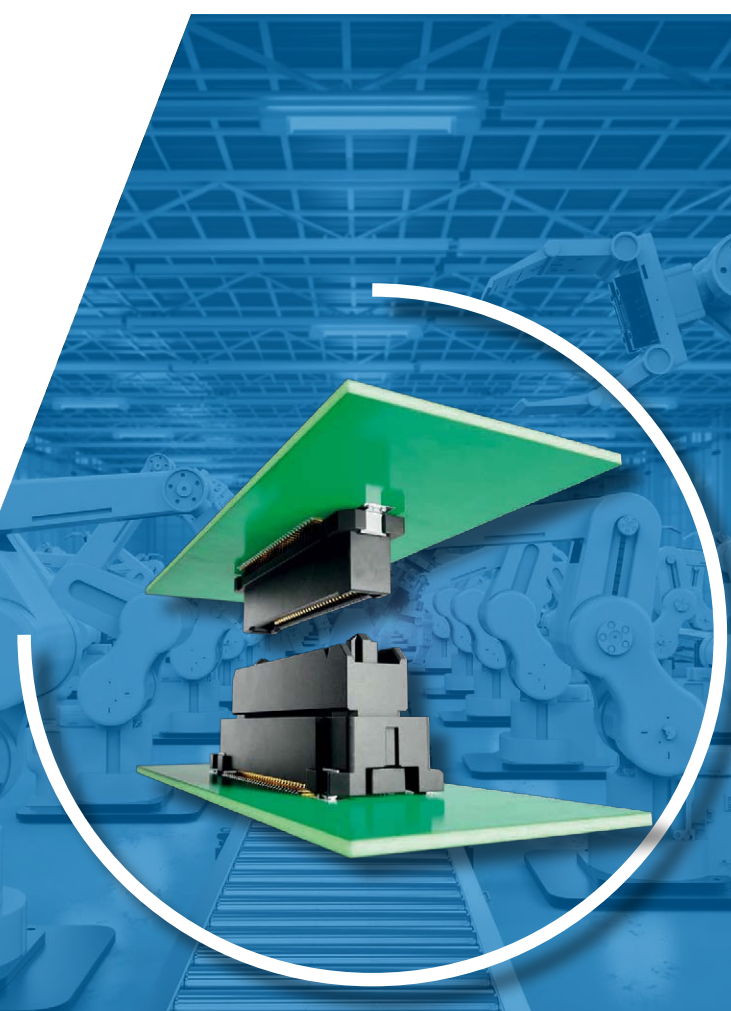



Simply solving EMI and ESD requirements

# Practical tool available in various formats

*Many challenges in electronics production and applications can be solved with the comprehensive Flex Suppressor product family: Signal integrity can be easily enhanced, crosstalk minimized, and the reliability of electronic devices increased.*

BY DANIELE CARNEVALE,  
CORPORATE PRODUCT SALES MANAGER  
INDUCTORS AT RUTRONIK

Every electronics developer is familiar with the issue of interference from frequencies on cables or printed circuit boards. Fortunately, there is now a flexible and easy-to-use solution to this problem: the Flex Suppressor series. Regardless of whether it is to pass EMC tests or to improve the overall application performance through protected signal integrity or improved communication range. Flex Suppressor comes in a range of shapes and variants, e.g. in various sheet sizes and as meter-long rolls and strips. In the following, the application is presented on the basis of three application areas.

*Reducing electromagnetic interference*

One of the biggest challenges in electronics is electromagnetic interference (EMI). This type of interference can significantly impact the performance of electronic devices, thereby leading to malfunctions.

When an application is impacted by electromagnetic interference, applying a piece of Flex Suppressor to the source or path of the interference can immediately and effectively resolve the issue. Due to its special structure and material composition, Flex Suppressor absorbs unwanted radiation emissions in a range from 30 MHz to 1 GHz. This results in more stable and reliable operation, particularly in applications subjected to high levels of electromagnetic stress.

The most important factors to consider in this application are the frequency range being covered and the space available for the thickness of Flex Suppressor. A thicker piece of Flex Suppressor is more efficient, but also more expensive. To find the optimum cost/performance ratio, the thickness must be weighed against the attenuation in the desired frequency range (Fig. 1).

An application scenario is shown in Fig. 2. In this case, the integrated circuit (IC) is the

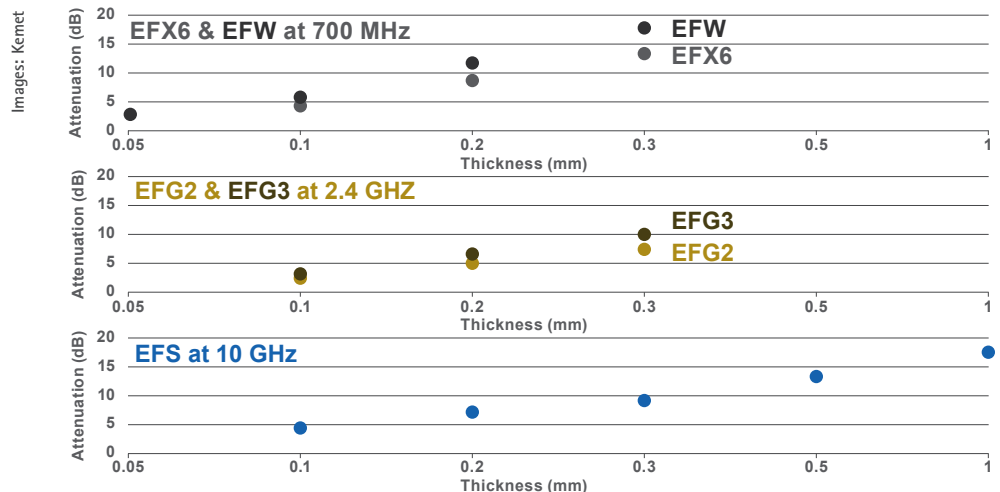

Figure 1: Attenuation based on thickness across various frequencies

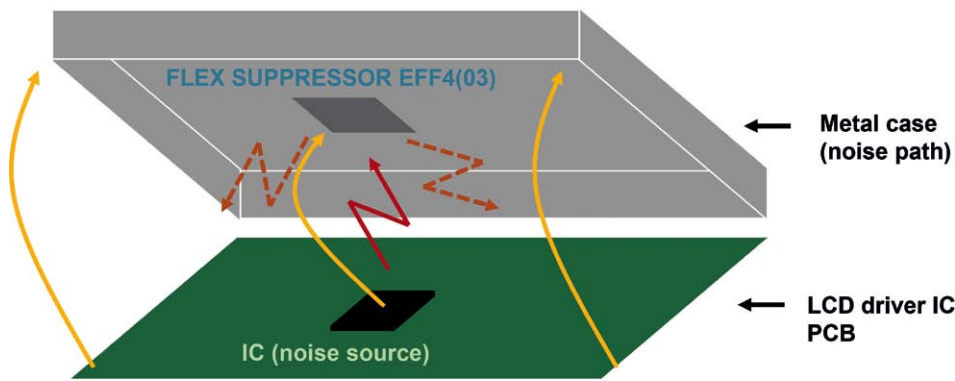

Figure 2: The EMI emissions of the IC are reduced by placing a piece of Flex Suppressor (e.g. EFF4(039)) directly above the interference source.

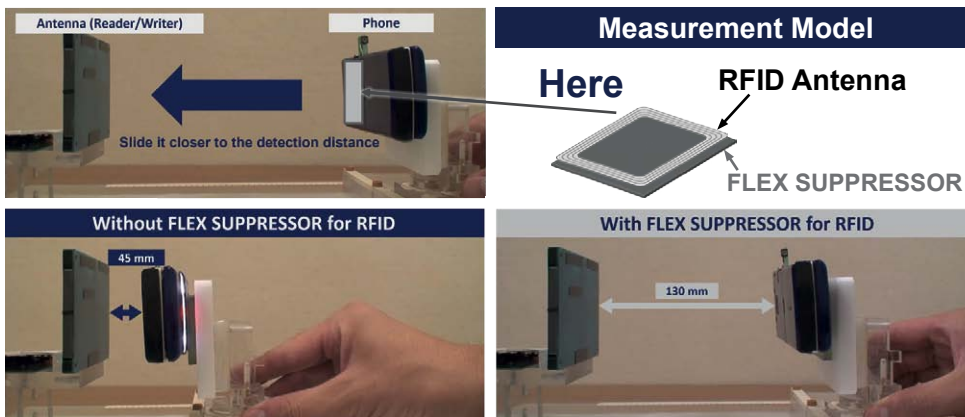

Figure 3: Enhancement of the communication range of a cell phone using Flex Suppressor

noise source. Due to reflections from the metal package, the EMI emission in the FM band exceeds the EMI regulations. An effective countermeasure is to attach a piece of Flex Suppressor (e.g. EFF4(039)) directly above the source of interference.

*Improved signal transfer*

As the demand for better reception sensitivity in high-capacity and fast mobile devices grows, noise-canceling measures in high-frequency bands are becoming increasingly crucial.

**Flex Suppressor**

- protects against the effects of radiated noise at the source or on the transmission line,
- is effective against high-frequency interference generated by electronic devices, and
- minimizes crosstalk.

This improves signal purity and increases the reliability of data transmission. And this is vital for applications in high-frequency tech-

nology, telecommunications, and other fields where precise signal transmission is essential.

The range of possible applications is almost unlimited. The thin, flexible material can be cut into any shape and is ideal for use in portable devices or in areas with limited space. Further, Flex Suppressor can be used in a wide frequency range from MHz to GHz.

Fig. 3 shows the effect of Flex Suppressor on the RFID antenna of a cell phone. In this test, the cell phone is used as the transmitter and the antenna (read/write device) as the receiver. The actual communication range can be determined by moving the cell phone toward the antenna. Flex Suppressor helps to triple the communication range. This can determine whether direct contact is still necessary for NFC or RFID, or if gesture-based interactions can be conducted from a distance.

*Suppression of interference from cables*

Electronic devices and systems are often impacted by interference from unshielded cables. This interference can be caused by electromagnetic fields emitted by neighboring cables or external sources.

The latest addition to the Flex Suppressor family is the flexible EST tape, a suppressor tape. A major advantage is its ease of use: The EST tape is simply wrapped around the outer surface of a cable and can be shortened to the required length without the need for cutting tools. It is therefore ideal for quickly and easily checking EMI noise sources and for EMI troubleshooting, especially during the test phase. Developers can use it to carry out initial tests in order to determine how much shielding is required for the respective application.

In summary, using Flex Suppressor products helps manage and optimize the electromagnetic environment of electronic systems, ensuring reliable and trouble-free performance.

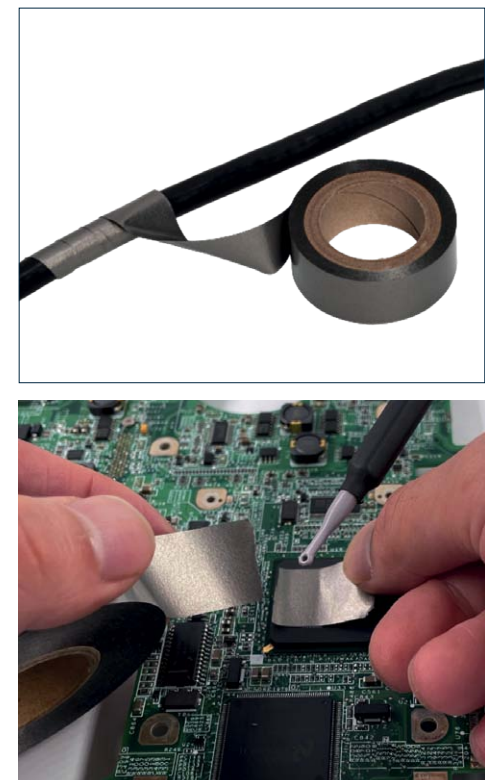

Figure 4: EST tape is easy to use and mainly applied for troubleshooting in the test phase



Development of a customized connector system for high currents

# New development in nine months

*Customized connectors are the ideal solution when standard parts make the end product unnecessarily complex or expensive.*

*A new development ensures safe heat dissipation at high currents.*

BY MARTIN PFALZGRAF,  
TECHNICAL EXPERT CONNECTORS  
AT RUTRONIK

A motor control supplier faced the challenge of increasing the performance of a motor control without enlarging the system's dimensions. The electrical connection between two printed circuit boards was particularly challenging, as twice the current had to be transmitted in the available space.

A motor control supplier approached MPE-Garry with this task. MPE-Garry brings years of experience in customized connectors, offering solutions ranging from near-series pin headers and socket connectors with special dimensions to adapter solutions, connector systems with integrated functional units, and complete cable harnesses.

MPE-Garry's development team collaborated directly with Rutronik and the customer to create a connector system solution that meets all the requirements. Additional requirements for the system included a current carrying capacity of 20 A per contact, 5.08 mm spacing, and sockets for SMD mounting. Furthermore, two versions were to be developed, one with four contacts and another with eight contacts.

*Compact dimensions  
require a new contact system*

The extremely compact dimensions necessitated the development of an entirely new contact system for the socket. The electrical resistance of the contact system had to be minimized to prevent power loss and avoid heating of the system.

To meet these requirements, a connector system featuring a specialized lamella contact was developed. A key component of the contacting system is the "power flat connector socket," which features a mechanically sealed socket shaft that connects with a flat connector (Fig. 1).

This socket contact has a robust and stable design thanks to its box profile. Additionally, the high number of contact points within minimal space reduces the contact resistance.

When inserting the contact blade, the two apices of the contact bars can be overcome sequentially rather than simultaneously. This smooths the force-displacement curve when the contact blade is inserted into the socket. The contact consists of only one part, allowing for fully automated manufacturing at particularly low costs.

*Heat dissipation  
under full load*

A key element of this contact system is controlling temperature problems under full load. A special design was found for this purpose: The relatively cool air surrounding the contact system is drawn into the system through convection via the gap between the base and the printed circuit board, as well as through the side slots in the upper part of the connector. The heated air rises through the chimney-like holes in the base. This chimney effect ensures that the heated air is dissipated through numerous slots in the upper part of the connector.

*Everything from  
a single source*

The development of the new connector, along with all the necessary tools for series production, was completed in just nine months. All necessary product requirements were addressed within the group of companies.

The insulation inserts of the prototype were produced using 3D printing. The contacts were laser-cut and then shaped using specially designed bending devices. This allowed the prototypes to be tested for their current carrying capacity before investing in series production





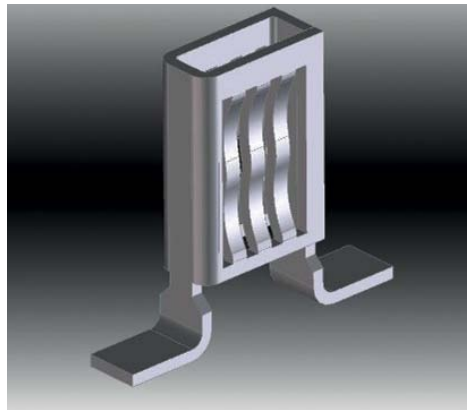
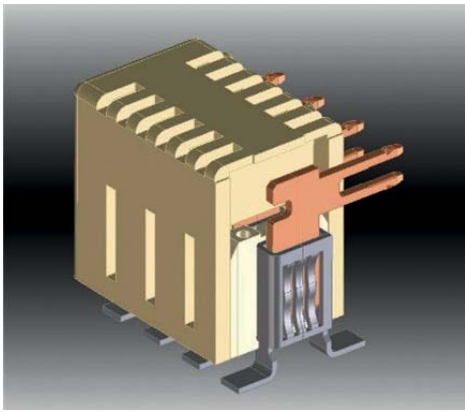
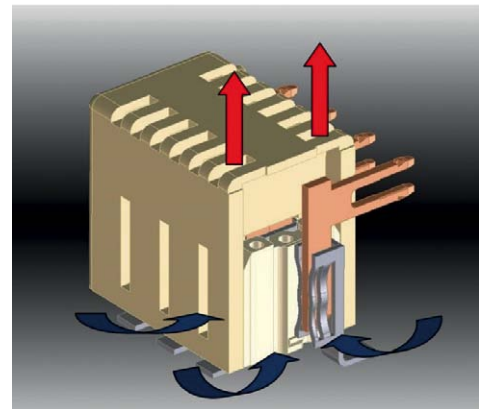

Figure 1: Cross-section of the contact system (left), and the socket contact (right)



Images: MPE-Garry

Figure 2: Heat dissipation at the contact system: The heated air is discharged upwards through chimney-like holes

tools. Waiting times could thus also be reduced.

Additionally, final assembly and shipping take place in-house, ensuring high quality throughout the entire value chain. The connector system is certified to DIN EN 61984 VDE 0627. MPE-Garry prepares all the necessary documentation (here EMPB). On request, MPE-Garry can also provide PPAP documentation.

Further advantages of customized connectors include:

- Cost-optimized end product
- Combining multiple functions in a single connector, e.g. signal and power supply within one component
- Cost-optimized production
- Significantly simplified installation of the end device
- Optimum suitability for an end product in

terms of resistance, dielectric strength, temperature range, and impedance

- Improved functionality thanks to optimum adaptation of the connector to its function
- Competitive edge through smaller installation space

*Special thanks go to Peter Fuchs from the Rutroniker editorial team for his support in preparing the technical article.*

Advertisement

# GOWIN

PROGRAMMING FOR THE FUTURE

## Advanced FPGA Next Generation Applications Automotive, Industrial, Medical, Consumer

**Arora - V**  
GW5A/R/T/S/ST  
22nm 15K to 138K LUTs



**High-Performance 22nm FPGA**    **High-Speed Interfacing**  
SerDes, PCIe, DDR3, LVDS,    DisplayPort, eDP, HDMI,  
MIPI CPHY & DPHY, ADCs    PCIe 3.0, USB3.2

**Arora**  
GW2A/N/R/NR  
10K to 55K LUTs



**Interfacing & Control**    **Video Bridging & IO Expansion**  
DDR3, LVDS    Extended On-Chip Memory Options  
MIPI D-PHY & C-PHY    SDR/DDR SDRAM, pSRAM & Flash

**LittleBee**  
GW1N/R/S/Z/SER  
1K to 9K LUTs



**Flexible Multi-Purpose**    **ARM Cortex-M3 μSoC**  
Inc Ultra-Low-Power    Extended Memory Options  
MIPI D-PHY & C-PHY    SDRAM, pSRAM, Flash



**GOWIN Semiconductor** provides the vision, expertise and support to accelerate customer innovation using our wide range of FPGA devices and freely licensed IP Cores & EDA Tools.

[www.gowinsemi.com](http://www.gowinsemi.com)

The Intel Atom logo consists of the word "intel" in a small, lowercase, sans-serif font above the word "ATOM" in a larger, uppercase, sans-serif font. The text is white and set against a blue square background with a subtle grid pattern.

intel.  
ATOM

The Intel Core i3 logo features the word "intel" in a small, lowercase, sans-serif font above the word "CORE" in a larger, uppercase, sans-serif font. Below "CORE" is the "i3" logo, which is a small "i" followed by a "3". The text is white and set against a blue square background with a subtle grid pattern.

intel.  
CORE  
i3

Power-efficient  
performance for AI,  
graphics, and media  
processing at the edge

**Intel Atom<sup>®</sup> processors x7000E Series  
and Intel<sup>®</sup> Core<sup>™</sup> i3 processors**

Support accelerated AI, media processing workloads, and up to three 4K displays in compact, fanless designs. Intel<sup>®</sup> Advanced Vector Extensions 2 (Intel<sup>®</sup> AVX2) and Intel<sup>®</sup> Deep Learning Boost plus Intel<sup>®</sup> UHD Graphics bring new capabilities to 6W to 15W edge applications.

## Efficiency plus performance for edge applications

Intel Atom® processors  
x7000E Series

Up to four Efficient-cores  
Up to 24 execution units (EUs)  
6W–12W TDP

Intel® Core™ i3-N305  
processor

Eight Efficient-cores  
32 execution units (EUs)  
9W–15W TDP



### Designed for deep learning AI<sup>1</sup>

#### Intel® Deep Learning Boost

Accelerates deep learning inference workloads on the CPU.

#### Intel® UHD Graphics

Integrated GPU processes inference workloads at FP32, FP16, and INT8 precision.

Fully supported by the OpenVINO™ toolkit

Optimized inference engines autodetect hardware and load balance workloads across CPUs, GPUs, and accelerators.



### Supports ultrahigh-definition displays and video processing<sup>1</sup>

#### Intel® UHD Graphics

Driven by Intel® Xe<sup>e</sup> architecture, the integrated GPU drives up to three concurrent 4K60 SDR displays.

#### Pipelock synchronization

Sync two displays for video wall applications using Pipelock on Windows OS.

#### Media API

Programmable processing for precise control of image quality, encode/decode performance, and acceleration.



### Enhanced for embedded IoT edge applications<sup>1</sup>

#### Real-time computing

Intel® Time Coordinated Computing<sup>2</sup> and integrated 2.5GbE Time-Sensitive Networking-capable MAC to support deterministic workloads and networking.

#### Hardware virtualization

Intel® VT-d/x plus support for open source and proprietary hypervisors allow workloads to run in isolation simultaneously.

#### Multiple operating systems

Run Windows, multiple versions of Linux, plus real-time operating systems from Wind River, QNX, and others.

## Significant gains in performance and capabilities

Intel® Processor N200 posts significant performance gains over Intel® Pentium® N6415 processors.

Up to  
**1.30x**  
faster  
single-thread  
performance<sup>3</sup>

Up to  
**1.68x**  
faster  
graphics  
performance<sup>3</sup>

Up to  
**1.09x**  
faster  
multithread  
performance<sup>3</sup>

Up to  
**6.85x**  
faster GPU  
object detection  
inference  
performance<sup>3</sup>

## Do more within a 6W–15W power budget



#### Retail

Small footprint and mobile point-of-sale (POS) systems with computer vision and multidisplay support.



#### Healthcare

Portable imaging devices with UHD graphics and onboard deep learning AI.



#### Office automation

Copiers, printers, and scanners with AI-powered image and text recognition.



#### Safety and security

Entry-level network video recorders and appliances with deep learning AI capabilities.

Rutronik  
is an Intel® Authorized  
Distributor.



#### Notices and disclaimers

- Not all features are available on every SKU.
- Intel® Time Coordinated Computing will not be available at launch. It is part of a planned update after launch.
- Performance varies by use, configuration, and other factors. Learn more at [intel.com/processorclaims](https://intel.com/processorclaims): Intel® Processors.

Intel is committed to respecting human rights and avoiding complicity in human rights abuses. See Intel's [Global Human Rights Principles](#). Intel® products and software are intended only to be used in applications that do not cause or contribute to a violation of an internationally recognized human right.

Intel® technologies may require enabled hardware, software, or service activation.

No product or component can be absolutely secure.

Your costs and results may vary.

© Intel Corporation. Intel, the Intel logo, and other Intel marks are trademarks of Intel Corporation or its subsidiaries. Other names and brands may be claimed as the property of others.



Temperature sensors in SMD format for power electronics

# On the way to becoming standard connection technology

*The combination of silver sinter technology and SMD assembly forms the basis for high-performance, reliable, and compact temperature sensors that meet the requirements of state-of-the-art and next-generation power electronics.*

BY BERT WEISS,  
TECHNICAL EXPERT RESISTORS  
AT RUTRONIK,  
AND MARTIN BLEIFUSS, HEAD OF PRODUCT  
MANAGEMENT AT YAGEO NEXENSOS

**S**ensor technology is a key technology in the modern world. Precise temperature detection and control ensure safe, efficient, and sustainable operation in a wide range of applications such as power generation, health care, and mobility. As the shift towards electromobility continues, temperature measurement is emerging as a key innovator once again.

The performance, speed, and efficiency of every electric vehicle are determined by the layout and capabilities of the voltage converter and inverter units. Increased switching frequencies, higher power levels, and operation at elevated temperatures allow for greater driving ranges and more dynamic driving modes. However, higher operating temperatures demand new materials and new joining techniques.

*Simplified design by eliminating etched trenches*

The sinterable Pt1000 temperature sensor in an SMD package was developed to optimize power modules (Fig. 1). The electrical isolation between the sensing layer on the top side and the back side metallization enables potential-

free positioning of the temperature sensor adjacent to the heat source. The sensor and other components can be installed at the same electrical level and on the same substrate. The need to mount the sensor chip on a separate "island" is eliminated. Omitting the additional etched trench that is required for the potential-free mounting of through-contact components (NTC type) reduces the design effort on the substrate level. Reducing the size of the substrate contributes to smaller components and supports the overall trend towards miniaturization.

Connection of the sensor element can be achieved through standard thick-wire bonding; connection to the PCB is feasible with standard silver sinter processing, which allows for seamless integration in standard production processes. Fig. 2 shows a comparison of the design options for SMD and NTC sensors.

The sinter connection is the key to high-temperature operation, opening the operation window far beyond 200°C. While the Pt1000 sensor element is currently specified with an upper operating limit of 200°C, ongoing development activities target higher temperatures where the limits of the sinter connections can be further utilized.

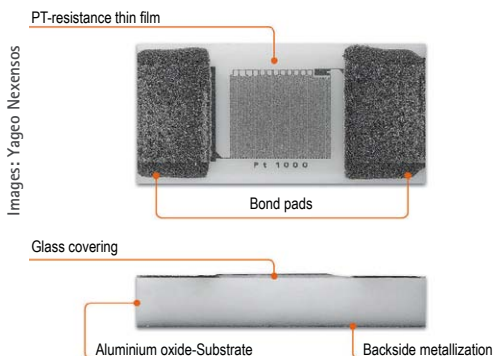

Figure 1: The Pt1000 SMD-SC temperature sensor has bond pads (AgPt) for thin and thick wire bonding and back side metallization optimized for silver sinter processing (AgPd).

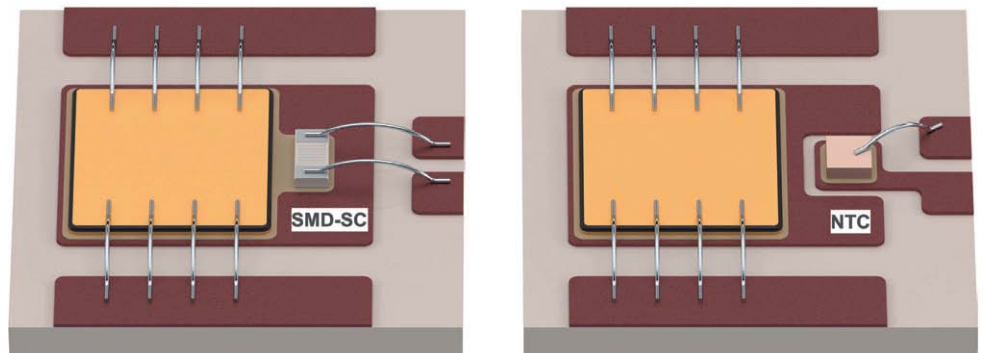

Figure 2: Design options for electrically isolated (left) and NTC temperature sensors (right)

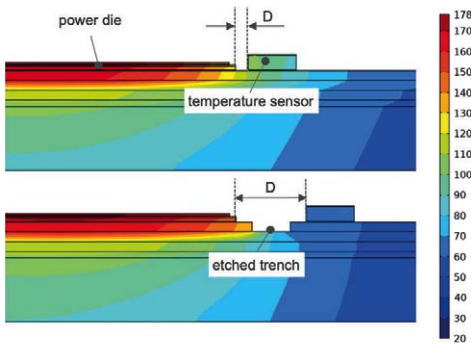

Figure 3: Temperature distribution in power modules operated at 150°C junction temperature; top: substrate geometry without etched trench; bottom: additional etched trench for electrically isolated position of the temperature sensor

### Measuring accuracy and response time

To better understand the impact of sensor positioning on the printed circuit board, a simplified model was employed to investigate heat distribution and response times in state-of-the-art silicon-based power modules as well as next generation silicon-carbide-based setups. The chosen design geometry is independent of the material selection. The material properties and the operating temperature have been adjusted to resemble Si- and SiC-based designs.

The model calculations show that the deviation between the junction temperature (150°C or 200°C) and the measured temperature is strongly influenced by the distance between the sensor and the power semiconductors. Fig. 3 and 4 show the dependency of the tem-

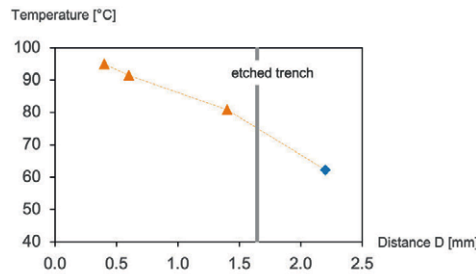

Figure 4: Detected temperature as a function of the distance between the power die and the temperature sensor. The position of the additional etched trench is marked as a double gray line.

perature drop on the distance. As a result of the electrical isolation between the sensing area and the back side metallization optimized for sinter connections, the SMD-PT sensor can be placed on any available position on the power module PCB. The reduced distance between the heat source and the sensor element results in higher accuracy of the measurement results.

The response time is also influenced by the positioning of the sensor. A greater distance leads to a much slower response and a pronounced delay after the switch-on step. The time to reach equilibrated conditions is best described by the delay to reach 90% of the equilibrium temperature  $t_{90}$  (Fig. 5). Comparing the  $t_{90}$  times for sensor position 1 and 2 with 1.0 and 1.3 seconds reveals a substantially more dynamic detection with a 30% faster detection for the position close to the power dies.

The shorter distance between the Pt1000 SMD-type temperature sensor and the heat

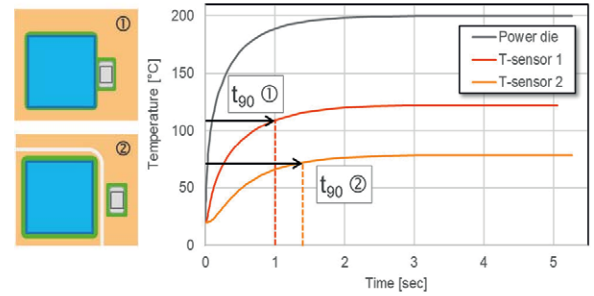

Figure 5: Temperature response when switching on the power die. Temperature sensor 1 is located in proximity to the power die, temperature sensor 2 is separated from the power die by an etched trench

source not only improves the measurement accuracy but also significantly reduces the time to reach thermal equilibrium, resulting in a much shorter temperature measurement response time.

### Summary

The sinterable Pt1000 temperature sensor in an SMD package offers a variety of benefits for solving temperature sensing challenges in state-of-the-art and next-generation power modules: The layout of the sensor with intrinsic isolation between the sensor and the contact layer allows for new designs and elimination of the etched trench. The reduced distance between the heat source and the sensor element results in higher accuracy and shorter temperature measurement response times. Overheating effects and temperature spikes can thus be avoided, and the overall life expectancy is significantly increased. ■

Advertisement

# Welcome the K3836-Q/-R mITX

- Successor to well-known D3633-S
- Latest Intel® Core™ Processors (14th Gen)
- Intel® Q670 & R680E available

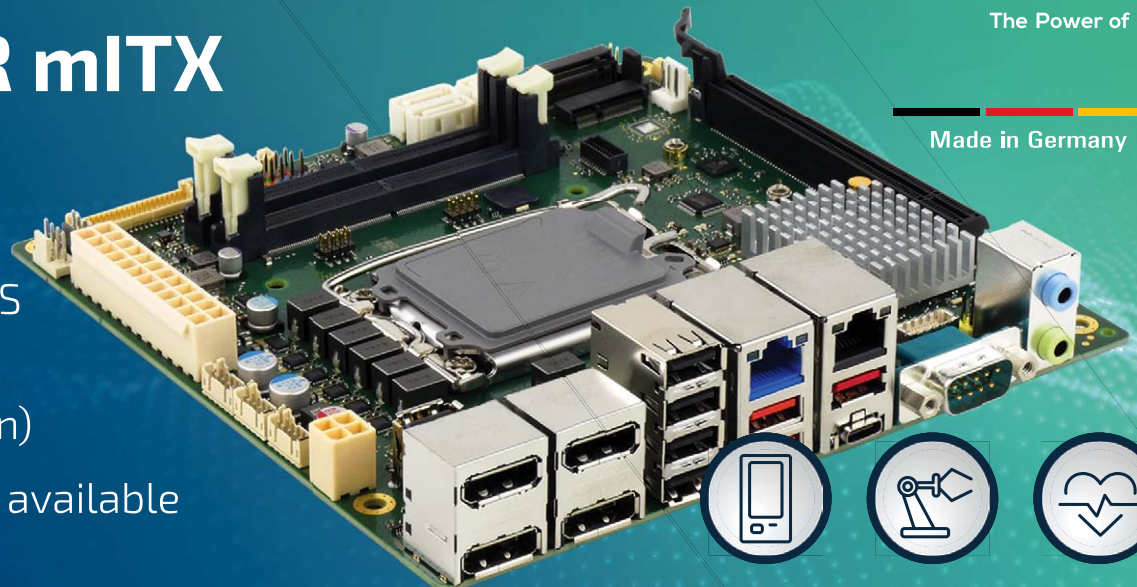

**kontron**  
The Power of IoT

Made in Germany



Ethernet transformers for high-performance networks

# For data transmission rates up to 10 Gbit/s

*High-performance Ethernet transformers are essential to meet the demands of modern, high-performance network devices. They ensure reliable and secure data transmission, optimize signal quality, and enhance the overall performance and efficiency of the network.*

BY DANIELE CARNEVALE,  
CORPORATE PRODUCT SALES MANAGER  
INDUCTORS AT RUTRONIK,  
AND JOCHEN NELLER, TECHNICAL EXPERT  
INDUCTORS AT RUTRONIK

Every connectable device must have a processor and a communication channel. The connection between the digital and analog levels is established by a PHY (physical layer transceiver), the silicon chip/IC. It acts as the physical layer interface between these two levels. Simply put, it is a data transmitter with galvanic isolation that sends and receives high-speed digital signals to and from other devices via Ethernet cables.

Developers of LAN (local area networking) circuitries often encounter the need to use high-frequency (HF) transformers (pulse transformers) as part of the analog interface in their circuitry. These pulse transformers are used for impedance matching, voltage matching, and/or isolation, or as a barrier between external cables and internal digital circuitries. LAN transformers from Pulse offer the essential isolation needed to ensure proper network functionality and communication, while also meeting the industry standards set out by IEEE under IEEE 802.3. All discrete LAN products

from Pulse are designed to operate with PHY chipsets from the respective suppliers, depending on the desired Ethernet data rate from 10Base-T (10 Mbit/s) to 10GBase-T (10 Gbit/s). Choosing the right component is crucial, as the module must support Ethernet data transmission through the transformer without introducing delays, distortion, or additional noise from EMI/EMC.

We often talk about modules when filter coils (e.g. common-mode chokes) are present in the package in addition to the transformer. They block unwanted interference and noise. The modules often also offer Power over Ethernet (PoE). This allows for the secure transmission of direct current over the same 8-wire network cable, whether shielded (STP, shielded twisted pair) or unshielded (UTP, unshielded twisted pair), that also supports the Ethernet data signal (Fig. 1).

### Use in local networks

A local area network (LAN) comprises all Ethernet-based connection devices that are located within a radius of roughly 100 meters from the location of the main computer or server. The connected devices form a network, but they may not all share the same power source or common ground. There are potential differences between the connected devices.

Digital data signals are transmitted between the connected devices via connected cables. Isolating the data line prevents signal degradation, ensuring that "0" and "1" can be read. The reduction of interference and noise also helps maintain the integrity or purity of the data signals.

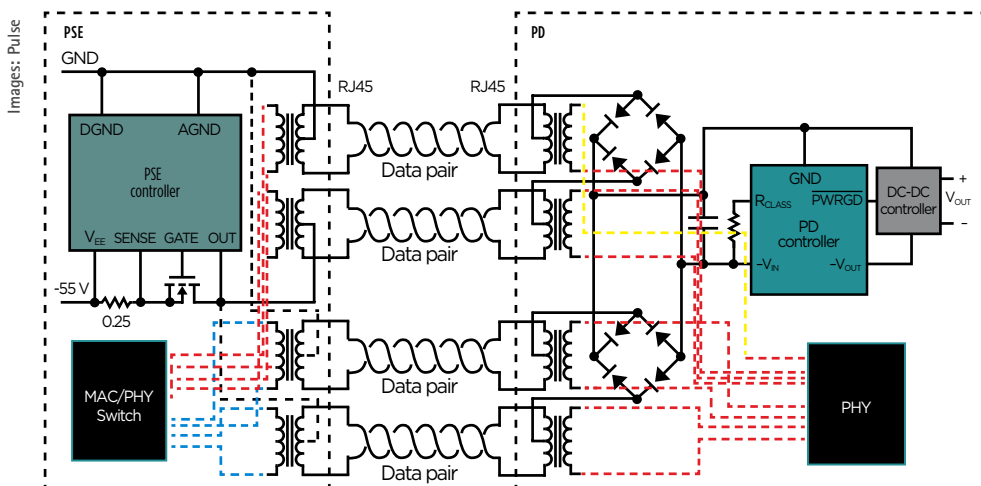

Figure 1: PoE mode of operation

<b>Data rates – LAN devices</b>	100Base-Tx, 1000Base-T, 2.5GBase-T, 5GBase-T, HDBase-T, 10GBase-T, and 25GBase-T
<b>Data rates – automotive</b>	100Base-T1, 1000Base-T1, 10Base-T1
<b>Installation options</b>	THT, SMT, Pin-in-Paste, BGA
<b>Multiport options</b>	Single, Dual, Quad, Octal
<b>Package configurations</b>	PCMCIA and Low Profile
<b>Temperature ranges</b>	0 to 70°C, –40 to +85°C/105°C/125°C

Table 1: Key features of Pulse transformers

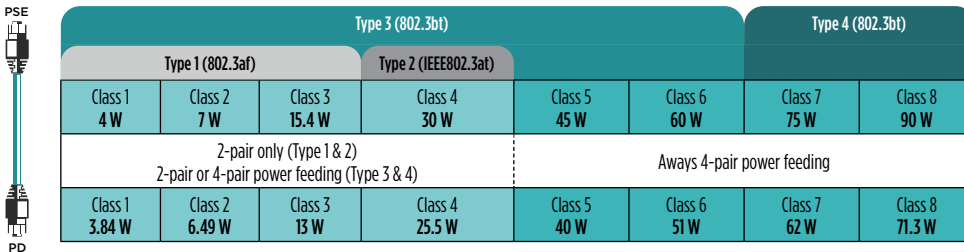

Figure 2: Demand and reference power level by type, class, and PoE device

Transformer modules provide isolation to eliminate unwanted effects from floating grounds, ensuring clean validity of the digital data signal. Integrated chokes suppress noise and also ensure EMC safety.

*Simultaneous data and energy transmission*

In conjunction with PoE, which allows for the transmission of both data and electrical power via an Ethernet cable, high-performance Ethernet transformers are crucial.

PoE LAN transformers do not provide a DC power supply themselves. They only support the differential data signal path via the transformer and block the passage of the direct current. The direct current must therefore be fed in on the external cable side and is only accessible via the central tap of the transformer. This means that the LAN transformer handles the PoE load current through its windings, and the design of the transformer module takes this into account.

Originally, there were two PoE variants with two wire pairs. The type of power supply de-

pendent on the type of connection: Mode A, where power and signal were combined, or Mode B, where power and signal were separated. Today, the focus is on solutions using four wire pairs of Type 3 (high power, 60 W) and Type 4 (high power, 90 W), which have increased the load capacity of each connection (Fig. 2).

*Ethernet transformers for high-performance applications*

Pulse has launched its latest discrete LAN components HBxxxxHLT and HXBxxxxHLT. Both series offer a high isolation voltage (typically up to 1,500 V RMS), low losses, and a compact design. They are robust and suitable for harsh environments. Each SMT module includes the necessary combinations of isolating transformer and common-mode choke to comply with IEEE 802.3 standards for data rates of 10/100Base-TX, 1000Base-T, 2.5/5GBase-T and 10GBase-T. This makes them particularly suitable for high-performance Ethernet applications (Fig. 3).

The HBxxxxHLT series covers the commercial temperature range from 0 to 70°C. The HX-

BxxxxHLT series is designed for industrial and outdoor applications that require an extended temperature range from –40 to +85°C. Additionally, the HB/HXB series support Power over Ethernet (PoE) and can provide up to 90 W DC via 4-pair Ethernet cables. The series offer excellent electromagnetic compatibility (EMC) and reduce electromagnetic interference (EMI), thus enabling interference-free data communication.

Another advantage: The discrete LAN components are manufactured at highly automated, cost-effective production lines. The high level of automation ensures scalability, reproducibility, and superior component quality. Table 2 shows a selection of products from the new series.

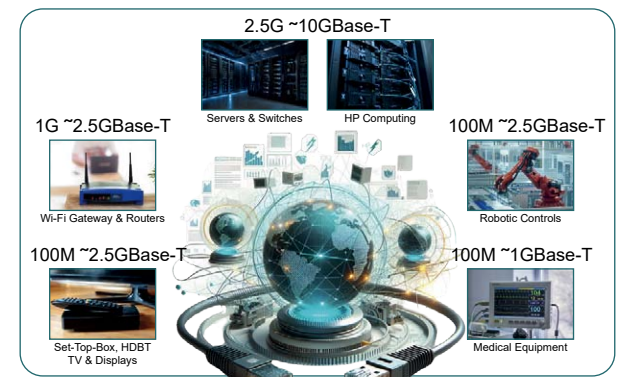

Figure 3: Application areas of the discrete LAN modules from Pulse

Part Number	Number of Ports	Mounting Style	Data Rate (Gbit/s)	Length (mm)	Width (mm)	Height (mm)	RMS Breakdown Voltage (V)	Winding Configuration	Operating Temperature (°C)	PoE Rating (W)
HXB6020HL	1	24 Pin SMD	1	15.10	10.00	5.80	1,500	2wCMC, XFM	–40 to +85	60
HXB6005HLT	1	24 Pin SMD	1	17.55	15.90	6.00	1,500	2wCMC, XFM	–40 to +85	60
HXB6008HLT	1	24 Pin SMD	1	17.55	15.90	6.00	1,500	2wCMC, XFM	–40 to +85	90
HXB4016HLT	1	24 Pin SMD	2.5	17.55	15.90	6.00	1,500	2wCMC, XFM	–40 to +85	90
HB4015HLT	1	24 Pin SMD	2.5	17.55	15.90	6.00	1,500	XFM, 2wCMC	0 to 70	60
HXB5G010HLT	1	24 Pin SMD	5	17.55	15.90	6.00	1,500	2wCMC, XFM	–40 to +85	90
HXB5G014HLT	1	24 Pin SMD	5	17.55	15.90	6.00	1,500	2wCMC, XFM	–40 to +85	90
HXB7011HLT	1	24 Pin SMD	10	17.55	15.90	6.00	1,500	2wCMC, XFM	–40 to +90	60
HXB7012HLT	1	24 Pin SMD	10	17.55	15.90	6.00	1,500	2wCMC, XFM	–40 to +90	90

Table 2: Product selection of the new HB/HXB series

Electromechanical actuators expand communication options

# For more sensitivity between humans and machines

*Electromagnetic haptic actuators are key elements in human-machine interaction. They convert electrical energy into tactile feedback and enhance the user-friendliness of electronic devices such as smartphones.*

BY SAMET KAYA,  
CORPORATE PRODUCT SALES MANAGER  
INDUCTORS AT RUTRONIK

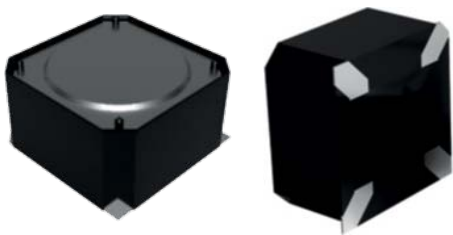

Measuring only 13 mm x 13 mm, HD-LA1307-SM provides a maximum linear acceleration of 1.8 G at a resonance frequency of 154 Hz. Another advantage: it is an SMD-compatible version.

**M**any products utilize visual and acoustic stimuli to convey information to users. Recently, a third dimension of information transfer has been increasingly used: the sense of touch. This concept, known as haptics, is being used in a growing number of market segments, including virtual and augmented reality (VR, AR), the Internet of Things (IoT), the automotive industry, and medical technology.

There are various technologies that are capable of providing haptic feedback. One option is haptic actuators. These actuators convert electrical energy into mechanical movement and provide users with tactile feedback. Vibration, touch sensors, and other tactile effects ensure diverse and realistic interactions with electronic devices. This enables a perfect interface between humans and machines (HMI) for the application.

Electromagnetic haptic actuators are generally divided into three main categories: ec-

centric rotating masses (ERM), linear resonant actuators (LRA), and voice coil actuators (VCA) or voice coil motors (VCM).

*Tangible vibration effects for smartphones, etc.*

**ERM actuators** generate vibrations through an eccentric rotating mass that is attached to a brushless DC motor (Fig. 1). If a voltage is applied to the motor, the actuator vibrates at a frequency that corresponds exactly to the frequency at which the mass performs a complete rotation. This results in a vibration strength that correlates directly with the control voltage of the actuator.

These actuators generate low-frequency, somewhat "rumbling" sensory feedback. This is due to the fact that the rotating motor requires a brief period of time to reach the desired speed when voltage is applied and similarly takes time to come to a complete stop when braking. ERM actuators are therefore an ideal choice when precise vibration patterns are not essential, but a distinct vibration effect is still needed. They are often used in smartphones and game controllers.

*For applications with high-level precision and fine tuning*

**Linear resonant actuators** (Fig. 2) generate vibrations using a method similar to the technology found in conventional speakers: in speakers, a membrane is connected to a coil and an electromagnet. When the coil is electrically energized, it moves the magnet and the membrane, thereby producing sound waves. In an LRA, a mass is attached to a coil instead of a membrane. When the coil is energized, the attached mass moves, creating linear oscillations. The mass moves in response

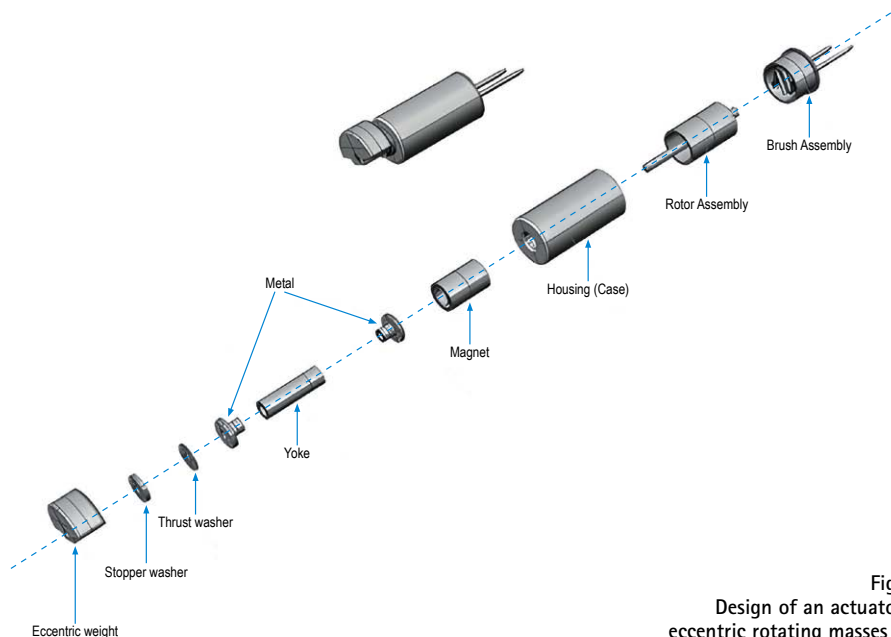

Figure 1: Design of an actuator with eccentric rotating masses (ERM)





Figure 2:  
Design of a  
linear resonance  
actuator (LRA)  
in a coin design

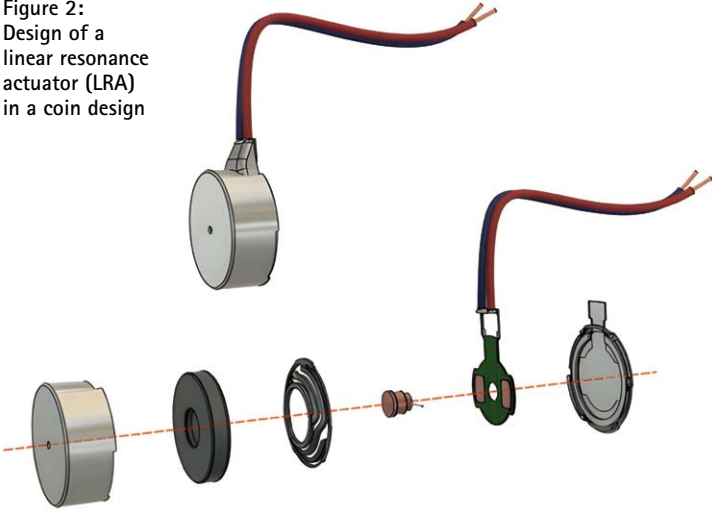
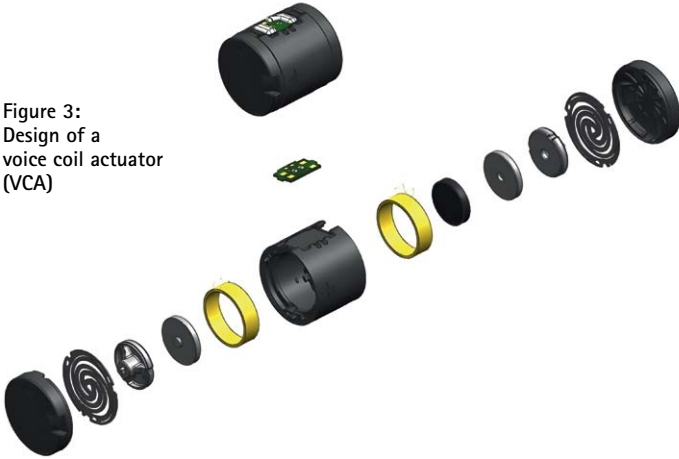

Figure 3:  
Design of a  
voice coil actuator  
(VCA)



to the frequency and voltage of the signal applied to the LRA, allowing independent control of both the intensity and frequency of the vibrations.

A major advantage of linear resonance actuators is their fast and linear responsiveness. In contrast to an ERM, there is no ramp-up time. During operation, the vibration is felt as soon as the coil is energized, and the mass moves up or down.

LRAs can create high-resolution, engaging vibration patterns that effectively convey information to users. Moreover, haptic driver ICs with integrated, preprogrammed libraries of vibration patterns are already available. These chips also include complex amplifier and boost circuits for direct actuator control.

LRAs are available in the smallest package shapes for haptic actuators. They are also extremely energy-efficient, which makes them a popular choice for wearables, for example.

LRAs are constantly being developed further. A special feature is the SMD-compatible ver-

# Su'scon

**Aluminum Electrolytic Capacitors**  
**Conductive Polymer Solid Capacitors**  
**Conductive Polymer Hybrid Capacitors**



[WWW.SU-SCON.COM](http://WWW.SU-SCON.COM)

Kuan Kun Electronic Ent. Co., Ltd





sions with a patent-pending design. HD-LA1307-SM from PUI Audio, measuring only 13 mm x 13 mm, provides a maximum linear acceleration of 1.8 G at a resonance frequency of 154 Hz.

*For a wide range of haptic effects*

**Voice coil motors (VCM) or voice coil actuators (VCA)** utilize a coil located in a magnetic field to produce linear movement (Fig. 3). As such, a variety of haptic effects are achievable: continuous vibrations, movements, or force feedback. VCAs ensure high-level precision and control over the generated haptic effects and are commonly used for VR applications, for example.

VCMs/VCAs are usually larger than LRAs. This results in a much stronger and more realistic vibration effect than can be generated with an LRA. At the same time, VCAs/VCMs consume more power than LRAs.

*Which actuator technology for which application*

Incorporating tactile feedback via haptic technology enables product designers to rethink how information is conveyed. It is important for design engineers to grasp the various actuator technologies and to choose the ideal haptic actuator for their product. The decision in favour of a suitable actuator tech-

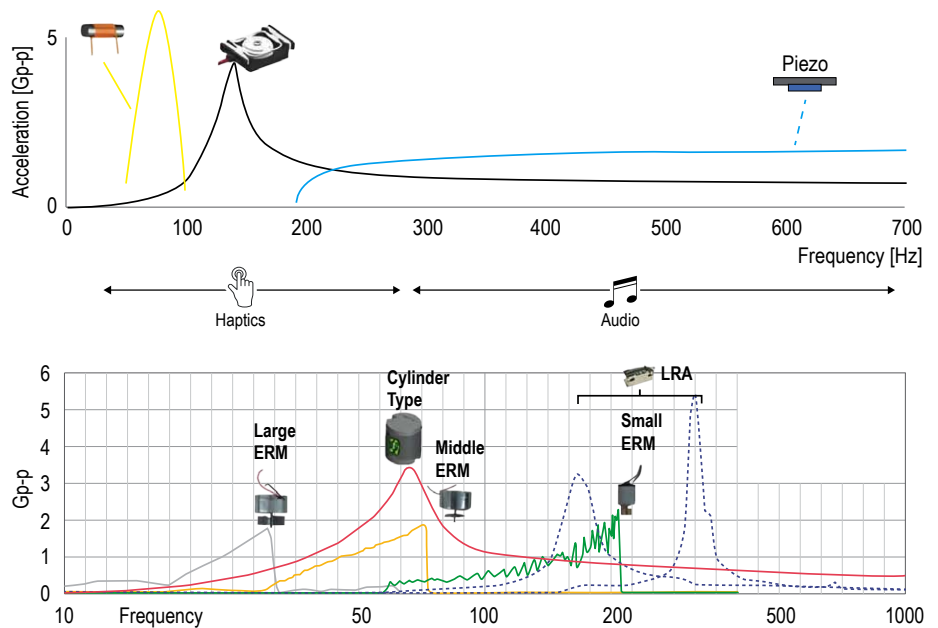

Figure 4: Comparison of various actuator technologies

nology depends on various factors. They include performance requirements, space demands, energy efficiency, weight, vibration characteristics, and costs. Fig. 4 shows a comparison of various technologies.

Both LRAs and VCAs have a specific frequency at which the overall system operates optimally, resulting in the highest vibration intensity. This means that LRAs and VCAs have a somewhat narrow working range in day-to-day operations. Developers are well advised to focus on optimizing the operating point of their hardware or software to align with this

range. ERMs, on the other hand, are not impacted by this limitation, as the vibration only changes in response to changes in voltage and not in frequency. This enables an extensive range of vibration frequencies.

The appropriate type of vibration for a design should be chosen during the product design phase by carefully evaluating the advantages and limitations of each type of actuator. Expert advice in the field of actuator technology can provide valuable insights. ■

Why polymer for capacitors

# The choice for advanced electronics

*The use of polymer capacitors in electronic circuits results in improved performance, reliability and durability, making them a popular choice in modern electronics.*

BY JULIO GÁLLEGO LÓPEZ,  
FIELD APPLICATION ENGINEER  
AT RUTRONIK

**P**olymer capacitors gained popularity in the 2000s. They have been used primarily in electronic equipment where high performance and reliability are essential. Key applications include computer motherboards, medical, aerospace, consumer and in-

dustrial electronics, and automotive electronics. In automotive electronics, polymer hybrid capacitors are booming. AEC-Q200s are used in engine control units, infotainment systems and other critical components that require a stable power supply and high reliability.

## Polymer technology

Polymer capacitors are a subset of electrolytic capacitors. The term "electrolytic capacitors" is derived from the use of an electrochemically formed oxide film on the electrode surface, which acts as a dielectric. Various metals, including aluminum (Al), tantalum (Ta), niobium (Nb), titanium (Ti), zirconium (Zr), hafnium (Hf), and others, can form a thin, highly insulating oxide. However, only three metals—aluminum, tantalum, and niobium—are currently in practical use.

The oxide film formed on the surface of the electrode becomes an electrical insulator and functions as a dielectric only when the electrode on which it is formed serves as the anode. Therefore, electrolytic capacitors are, in principle, polarity capacitors.

There are two main types of polymer capacitors—aluminum electrolyte and tantalum capacitors—which will be discussed in the next sections. Conductive polymers are also used

### First Layer:

- Wet Electrolyte Capacitor: paper spacer impregnated with electrolyte
- Hybrid Capacitor: paper spacer with conductive Polymer impregnated with wet electrolyte
- Solid Polymer Capacitors: paper spacer with solid Polymer electrolyte

Figure 1: Similarities and differences in the construction of polymer capacitors

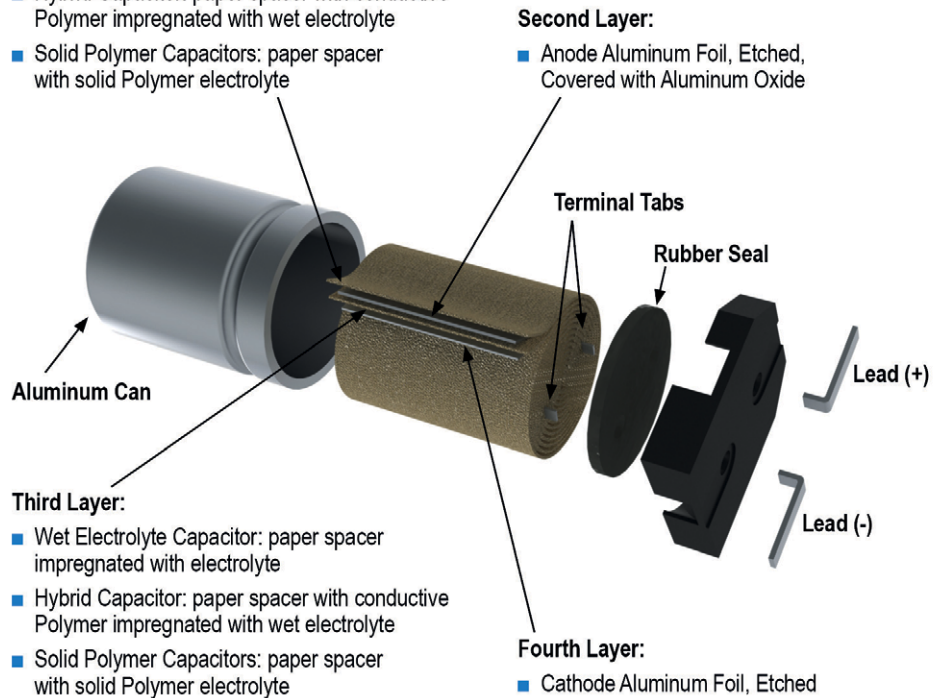

Advertisement



Creating Customer Centric Technology.

## The FTR-E1-HC, Compact, Lightweight, High Voltage DC Switching Relay for Power and Automotive Applications

- Lightweight only 75gr.
- Smallest size in its class, just 43.6 (L) × 28.3 (W) × 36.8 (H) mm for smaller PCB design
- Dielectric strength of 5,000VAC (1 min.) coil and contacts, 2,500VAC (1 min.) between contacts
- No specific polarity requirement for the connection of load terminals, for charge and discharge switching of the circuit
- Power consumption reduction is possible by applying holding voltage method
- Compliant with EN/IEC 61810-1:2015+A1





Key drivers	Aluminum wet electrolytic capacitors	Aluminum polymer capacitors	Hybrid capacitors
Lifetime	Decreasing the temperature by 10°C doubles the lifespan	Lifetime increases tenfold when the temperature drops by 20°C	It is calculated in the same way as for the electrolytic wet capacitor
Derating voltage	Derating is not required, but may increase lifespan; wet electrolytic capacitors can operate at 70% to 80% of the rated voltage, while hybrid and solid electrolytic capacitors can operate at 80% to 90% of the rated voltage.		
Rating voltage	Rating voltages of up to 450 V; high-voltage aluminum electrolytic capacitors available with ratings that can reach or even exceed 600 V	Rating voltages of up to 63 V, versions with up to 100 V available; trend is toward higher voltage ratings	Versions with rating up to 125 V available
DC bias	No DC-bias influence		
ESR	Typical ESR down to 20 mΩ; trend toward decreasing ESR	Ultra-low ESR, down to 5 mΩ	Between wet and solid, ESR about 11 mΩ
Ripple current	Not the best capability; electrolytic capacitors cannot withstand very high ripple currents	Very good ripple capability due to low ESR	Good capability
Vibration	Good performance under vibrations	Aluminum electrolytic capacitors with solid polymer are more rigid and less capable of absorbing vibration, making them more susceptible to mechanical damage in high vibration environments. Some manufacturers offer reinforced series designed to withstand high vibration.	
Temperature	Max. temperature up to 105°C, versions with max. temperature up to 125°C available	Max. temperature up to 125°C	Trend to increase temperature up to 150°C to extend lifetime
Capacitance stability vs. temperature and frequency	Poor high-frequency characteristics; capacitance drops significantly at 20 kHz; sensitive to temperature changes	Better high frequency performance; stable capacitance over a range of frequencies; capacitance drops significantly at 1 MHz; good temperature characteristics	
Leakage current	Electrolytic aluminum capacitors exhibit a higher leakage current compared to other technologies such as MLCC and plastic capacitors. The leakage current of an electrolytic capacitor is typically specified by the manufacturer and can be calculated using the empirical formula: <ul style="list-style-type: none"> <li>• <math>I_L = K \cdot C \cdot V</math></li> <li>• K: manufacturer-provided constant</li> <li>• C: Capacitance (F or μF)</li> <li>• V: Applied voltage</li> </ul> Manufacturers' data sheets provide accurate information on leakage current, although the exact formula and constants may vary from manufacturer to manufacturer.		

Table 1: Key drivers of various aluminum polymer capacitors

in aluminum capacitors to replace the wet electrolyte. These capacitors have a much lower equivalent series resistance (ESR) and do not dry out over time. The main applications of polymer capacitors are in DC-DC conversion/decoupling and automotive power distribution applications.

*Aluminum electrolytic capacitors*

Aluminum electrolytic capacitors are polarized capacitors in which the anode and cathode are made of aluminum. They can have either a wet electrolyte, a solid conductive polymer, or a hybrid (wet and solid conductive polymer) electrolyte. If these capacitors are

polarized, they should not be used in the presence of reverse bias.

In aluminum electrolytic capacitors, both electrodes are made of aluminum. The aluminum anode is separated from the wet electrolyte by an oxide layer, which is a paper foil saturated with the wet electrolyte. Different types of electrolytes enhance oxidation, operate at higher temperature ranges, and absorb gases that may form internally. The other aluminum plate, which serves as the cathode, is also present. The robustness of the anode aluminum foil depends on whether the capacitor must withstand higher voltages.

The construction of the polymer capacitor is strikingly similar. It consists of an anode and

a cathode, both made of aluminum foil. The dielectric is a layer of aluminum oxide (Al<sub>2</sub>O<sub>3</sub>) that acts as an insulator between the anode and the conductive polymer. A non-conductive layer (paper, film, or other insulating material) is placed between the conductive polymer, forming two layers of conductive polymer. Finally, a drying and aging process of up to 8 hours is performed.

Hybrid aluminum polymer capacitors combine the characteristics of both traditional aluminum electrolytic capacitors and polymer capacitors, taking advantage of each type. The dielectric is a mixture of liquid electrolyte and conductive polymers. The liquid electrolyte helps improve performance at lower frequencies and increases overall capacitance.

Figure 1 shows the similarities and differences in the construction of the different types of polymer capacitors.

*Self-healing process maintains performance and extends service life*

Small defects such as pinholes, microcracks, or areas of dielectric breakdown can form in the Al oxide layer due to electrical stress, thermal cycling, or mechanical strain. These defects create pathways for leakage current that can degrade capacitor performance.

When a defect causes an increase in leakage current, the localized area around the defect heats up. The conductive polymer layer reacts to this heat. The heat can cause the polymer to temporarily lose its conductivity in the localized area, effectively isolating the defect. The heat also promotes regeneration of the alumina dielectric layer at the defect site. This can occur by oxidation of the exposed aluminum at the defect site, where the aluminum reacts with oxygen (often from the polymer or the environment) to form new alumina.

The combined effect of polymer reaction and oxide regeneration seals the defect and restores dielectric integrity. As the defect is sealed, the leakage current decreases and the capacitor resumes normal operation. In hybrid capacitors, the presence of the liquid electrolyte enhances the self-healing process by allowing the aluminum oxide layer to reform more efficiently. Both types of capacitors rely on these self-healing mechanisms to maintain performance and extend service life.

The key drivers for various aluminum polymer capacitors are listed in Table 1.

---

### *Tantalum electrolytic capacitors*

---

Tantalum capacitors are polarized capacitors that use a solid electrolyte such as manganese dioxide ( $\text{MnO}_2$ ) or conductive polymer. However, care should be taken when applying reverse bias to this type of capacitor. The most notable properties of tantalum include high ductility, high corrosion resistance, high melting point ( $3,020^\circ\text{C}$ ), high heat and wear resistance, and high biocompatibility. Tantalum capacitors can replace MLCCs (Multilayer Ceramic Capacitor) in certain applications, subject to specific application criteria.

---

### *Solid tantalum capacitors*

---

Solid tantalum (Ta) capacitors use manganese dioxide as the cathode due to its self-healing properties. When defects occur in the dielectric, it becomes non-conductive. The tantalum is separated from the manganese dioxide by an oxide layer called tantalum pentoxide ( $\text{Ta}_2\text{O}_5$ ). When this layer is reduced, the manganese dioxide oxidizes the tantalum, forming a new oxide layer. As a result, these capacitors exhibit exceptional reliability with virtually infinite life.

The self-healing process can potentially release oxygen, which in extreme cases can lead to combustion. Nevertheless, tantalum capacitors are well suited for applications that require operation at higher temperatures.

In these capacitors, the conductive surface area significantly affects the capacitance (directly proportional), while the dielectric thickness inversely affects the capacitance. Despite their thinness, tantalum capacitors are robust (dielectric breakdown:  $470 \text{ V/mm}$ ), allowing for relatively high voltage applications.

Table 2 illustrates a comparison of dielectric thickness between Ta and MLCC capacitors. Notably, MLCC capacitors require a larger surface area and size to achieve high capacitance due to their thicker dielectric.

---

### *Tantalum solid conductive polymer*

---

Conductive polymers began replacing  $\text{MnO}_2$  in tantalum capacitors in the mid-1990s due to the higher conductivity of these polymers, which results in a significantly lower equivalent series resistance (ESR). The transition from  $\text{MnO}_2$  to conductive polymers offers sev-

# mpe



## NEW

## Cable Assemblies

- Custom cable harnesses based on your requirements
- Individually overmolded connector housings
- Single strands, cable sets, and a comprehensive range of cable harnesses
- Optional 100% final electrical inspection

## Battery Contacts

- Contacts according to customer specifications
- High-tensile spring steels ensure reliable contacting and high contact forces
- T+R packaging for automated assembly

## Terminal Blocks

- Various termination types such as screw terminals, spring terminals, IDC terminals, and plug-in terminals
- Available as solder, SMD, or pin-in-paste type
- Suitable for all common pitches
- UL certified

[www.mpe-connector.de](http://www.mpe-connector.de)



$V_R$	Dielectric thickness (nm)	
	Ta	MLCC
2	20.7	600
4	27.6	600
6	36.8	600

Table 2: Comparison of dielectric thickness between tantalum (Ta) and MLCC capacitors

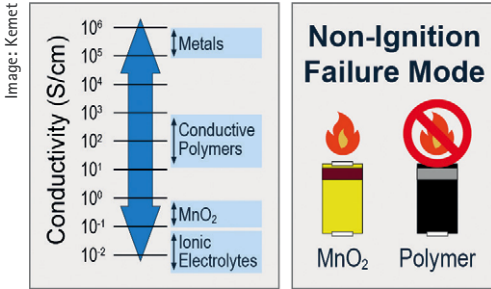

Figure 2: Advantages of Ta polymer capacitors: The conductivity of Ta polymer is higher than that of  $MnO_2$ , and the polymer is also non-flammable.

eral notable advantages, one of which is the self-healing mechanism.

If a dielectric breakdown occurs during operation (resulting in a short circuit or leakage path), the high current density at the defect site causes localized heating. This heat causes the conductive polymer to oxidize, rendering it non-conductive and effectively sealing the defect. This oxidation restores the insulating properties, preventing further failure and allowing the capacitor to continue operating.

Notably, these capacitors are considered safer because their self-healing process does not generate oxygen, minimizing the risk of inflammation, as shown in Figure 2. The main applications are DC-DC voltage rail converters. The key drivers of different tantalum capacitors are listed in Table 3.

Key drivers	Tantalum $MnO_2$	Tantalum polymer
Derating voltage	Requires a derating voltage of approx. 50%	10% applied Voltage lower than 10 V 20% applied Voltage higher than 10 V
Frequency behavior	Do not perform well at high frequencies; capacitance drops significantly at 10 kHz.	Good characteristics at high frequencies, especially around 100 kHz; if performance at 1 MHz is required, MLCCs are the best choice
Wear out mechanism / lifetime	Unlimited lifetime without aging	The cathode material wears out due to moisture and oxidation. As a result, the components will gradually degrade over time. The only way to prevent this degradation is to use hermetic packaging
Capacitance volume and energy density efficiency	Maximize capacitance per volume and energy density; achieve higher capacitance in smaller volumes and at higher voltages than other technologies	
ERS, ripple current and leakage current	The polymer has a significantly lower ESR than $MnO_2$ , allowing it to handle high ripple current. However, both tantalum polymer and $MnO_2$ have higher leakage currents than other technologies. Tantalum capacitors are not suitable when low leakage current is essential for maximum battery performance	
Robustness and piezo noise	Do not crack when bent, similar to; no piezo noise	

Table 3: Key drivers of different tantalum capacitors

*Weaknesses of tantalum polymer*

Tantalum polymer capacitors offer several advantages over traditional electrolytic capacitors, making them desirable for various applications. However, they do have some drawbacks and cannot be used in all scenarios.

The use of polymer capacitors is not recommended for frequencies approaching or exceeding 1 MHz, temperatures exceeding 150°C, or where maximum battery life depends on low leakage current.

Polymer capacitors are not suitable if the voltage is greater than 48 V DC, the application requires ultra-low ESR ( $\ll 4 \text{ m}\Omega$ ), low capacitance ( $< 0.68 \text{ }\mu\text{F}$ ), or reverse bias.

*Conclusion*

Polymer capacitors offer low ESR, high stability and reliability, high ripple current handling, improved safety, enhanced low voltage performance and better frequency characteristics. The use of polymer capacitors in electronic circuits improves performance, reliability and durability, making them a popular choice in modern electronics. ■

Advertisement

**KGS** KITAGAWA GmbH

Your global provider of premium EMC solutions

www.kitagawa.de



The supply chain A–Z

# Everything you need to know

*In this interview, Patrick Krätz, Head of Supply Chain Management, and Roman Wolf, Team Leader Supply Chain Management, provide insights into the areas of supply chain and logistics solutions, forecast management, and process optimization, emphasizing electronic automated data transmission.*

## What supply chain solutions do you provide, and which ones are currently most sought after by customers?

*Patrick Krätz:* We offer diverse solutions to support our customers' supply chains. The choice of model depends on many factors, such as turnover rates, value, quantity structure, risk assessment, end customer needs, efficiency potential, and other specific customer requirements. We develop and implement the process together.

*Roman Wolf:* Specifically, we are talking about delivery plan, kanban, and consignment systems. They can be combined with one another. However, electronic data interchange (EDI) is always the basis for this. The delivery plan procedure is currently in high demand due to its flexibility and ease of implementation. Additionally, we offer supporting modules such as safety storage facilities and C-parts management. We are also increasingly automating the standard ordering process, beyond the previously mentioned process variants. Supply chain optimization therefore knows no bounds.

## You are talking about a comprehensive, 360-degree view of the material flow. Could you briefly explain what this entails and what aspects you focus on when working with customers?

*Krätz:* We have to start with big data. Every month, we receive millions of data records from the most diverse sectors. These data records are continually updated. Most of these data relate to the supply chain. As an example, we can analyze supply security and supply reliability. This is done via customer orders or forecasts on the one hand and supplier orders on the other. By integrating replenishment lead times, current (consignment) store inventories, and historical sales



Patrick Krätz,  
Head of Supply Chain Management

“Thanks to our new forecast monitoring system, we can automatically compare customer forecasts after each import and verify their plausibility.”



Roman Wolf,  
Team Leader Supply Chain Management

“Particularly in the C-parts sector, optimizing material flow offers greater potential savings than negotiating prices in purchasing.”

or forecast data, you can gain a comprehensive view of a customer's supply chain over time. These analyses are updated regularly to reflect the current situation. This allows

us to detect supply chain disruptions early on and proactively engage with customers and suppliers.

*Wolf:* To handle and analyze the vast amount of data, we have tools at our disposal that visualize the supply chain and present it in a concise format. This also allows us to quickly identify faults at a glance. Using a drill-down feature, it is possible to navigate from an overview to individual items with a single click. Access is feasible on both the customer and the supplier side, enabling quick and agile analysis of a wide range of issues.

## And what about critical components? How do you collaborate with the customer to identify these issues, and what measures do you implement?

*Krätz:* We identify critical components at an early stage via our direct line to the suppliers. However, analyzing delivery times alongside increasing quantities per product group can also serve as indicators. Additionally, direct communication between our Product Marketing team, suppliers, and customers helps us identify new market trends and technologies and measure the associated capacity with the forecast volumes.

*Wolf:* In the worst-case scenario of insufficient stock, safety storage facilities, consignment stores, and our stockpiling strategy provide crucial support. However, these approaches are limited. In cases of prolonged supply bottlenecks, we collaborate with both the supplier and the customer to find solutions. To this end, we regularly coordinate to develop allocation plans, identify alternative products, and shorten transportation times, among other strategies. Here, too, electronic data exchange plays a crucial role in providing customers with automated, regular deliv-

Image: Uli Deck/dpa/picture alliance



View of the high-bay warehouse at Rutronik's logistics center in Eisingen

ery times for seamless integration into their ERP systems.

**What does your crystal ball predict? What is the current forecast for most customers?**

*Wolf:* Over the past year or two, we have frequently faced short-term demand reductions due to the dynamic market condition. Meanwhile, the demand situation has stabilized at a lower level. However, this can change rapidly, with demand and delivery times potentially increasing at short notice. We therefore always urge our customers to carefully review and scrutinize their requirements.

**Could you explain the core concept and benefits of Rutronik's new forecast monitoring system?**

*Krätz:* We have installed a new forecast monitoring system. This allows us to automatically compare and verify the plausibility of customer forecasts after each import. And we

are able to detect problems with the data interface or errors in the transmitted data. They are then automatically corrected and displayed.

*Wolf:* We can also align customer requirements with our own availability or potential shift time windows. For critical components, the database can be frozen, and delivery takes place according to agreement with the customers and suppliers. This way, we can guarantee allocation management.

**Are there any current risks of a renewed allocation? And if so, what do you believe is the primary reason for this?**

*Krätz:* The reasons are always different. You can list all the natural disasters, but also wars, terrorism, and wrecked ships. However, this information is of limited use since we must also anticipate such events in the future. What is crucial, though, is how you respond to and manage such circumstances.

Here, we often observe that people act impulsively. For example, people frequently order more than necessary and from multiple sources simultaneously. In the past, this led to some suppliers, as the final link in the supply chain, having a book-to-bill ratio of 4 on their books. No OEM, Tier-1, EMS, or the supplier themselves can produce this multiplication. Additionally, as a distributor, we are unable to store these quantities. Allocations are thus often influenced by human decisions and psychologically driven by exceptional situations.

*Wolf:* We are currently also observing a new contributing factor. The COVID-19 pandemic has significantly depleted resources and reduced the liquidity of many companies. This was quickly followed by the economic downturn, leading to full inventories in 2023 that many companies will continue to rely on during the economically weak year of 2024. As a result, many companies have been cautious about placing long-term orders for months. However, if all customers respond to an economic recovery simultaneously, suppliers will face the challenge of having to rapidly scale up production capacities. This would lead to the next phase of supply shortages. And remember: Electronic components are highly complex products. This complexity necessitates a long-term strategy for ordering electronic components, often involving lead times of several months depending on market conditions.

**In your experience, which automated process optimization options (EDI) are most crucial, and what have you found most effective in recent months?**

*Krätz:* Process optimization is divided into information flow and material flow. The flow is primarily optimized through data interfaces

Advertisement



Join us at **Electronica Munich 2024**

**| November 12 - 15**

**Hall C5 Booth 331**

- Explore our broad range of high-reliable electronic component
- Leverage our industry solutions to help you succeed in the next-generation design
- Gain insights from our industry experts on the latest market trends

Website



Contact

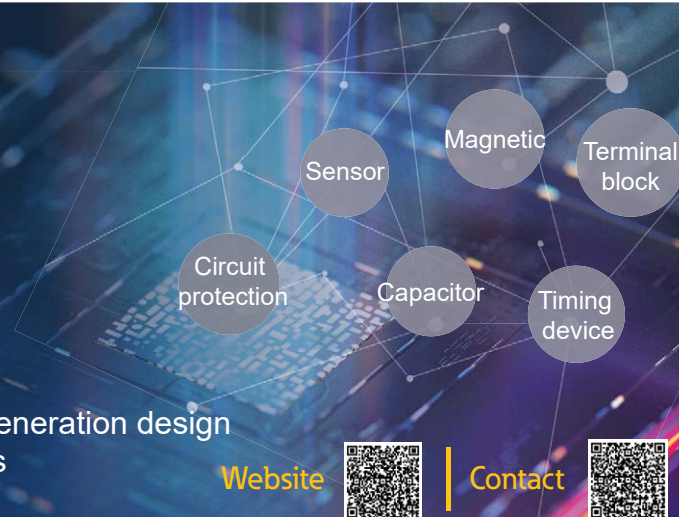





(EDI). Additionally, entire process steps can be eliminated if the appropriate contracts are in place. The goal should be to exchange only the information that is absolutely essential. Our forecast-based logistics systems come into their own here.

*Wolf:* The material flow is mainly optimized by consolidating quantities and using the largest possible packaging units. The fewer times a product is moved, the higher the efficiency. Determining the optimal delivery lot size is crucial. This benefits multiple departments, including the storage facility, order processing, and financial accounting, for both the customer and Rutronik. Particularly in the C-parts sector, optimizing material flow offers greater potential savings than negotiating prices in purchasing.

**How does the SCM team at Rutronik assist customers in finding the optimal solution for their individual process optimization?**

*Wolf:* The best-practice approach involves on-site analysis of the process and the articles in collaboration with the customer. The customer identifies weak points or bottlenecks, as they have a deeper understanding of their processes than we do. Moreover, there may be additional end customer needs or other industry-specific features. We then consolidate these results and incorporate our experience along with best-practice solutions. This provides us with an efficient and sustainable concept. After successful implementation, regular reviews are conducted to maintain a high level of efficiency.

**How do you manage to integrate the perspectives of various parties, such as Rutronik, the customer, the subcontractor, and the end customer? Have you gained initial experience in this area, and which approaches have proven to be most effective and sustainable?**

*Krätz:* Since these are typically partnerships between non-legally affiliated companies, system support can be challenging. Therefore, focusing on communication with all the parties involved is key. It is essential that each party understands their rights and obligations and fosters a mutual understanding of the challenges in the cooperation. Furthermore, regularly sharing any difficulties that arise with all the parties involved allows these constellations to be managed efficiently and sustainably. ■



**Elevating Automotive Solutions Tailored to Your Vision**

Adam Tech innovates automotive solutions tailored to your needs, empowering confident navigation of complexities from concept to validation.



**OEM & ODM EXPERTISE AND CAPABILITY**

Precision & innovation turn needs into designs, fostering collaboration. Expertise ensures meticulous solutions. Patent research (WISPRO) delivers uniqueness and testing guarantees reliability, instilling confidence.

 Concept Design & Advance Development	 Product Design	 Testing & Validation
---	---	---

Customization & value engineering set us apart:

- **VA/VE:** Identifying cost reduction opportunities without compromising quality.
- **SI Team:** Collaborating with ITRI experts for unparalleled insight.
- **DFM & DFMEA:** Minimizing risks and streamlining production.
- **In-House Expertise:** Full control over stamping, injection molding, die casting, and more.
- **Production Line & Automation:** Ensuring optimal efficiency and reliability.

For inquiries and partnership opportunities, reach out to us today. Experience the transformative power of customized automotive solutions. Let's accelerate innovation and redefine the automotive landscape.

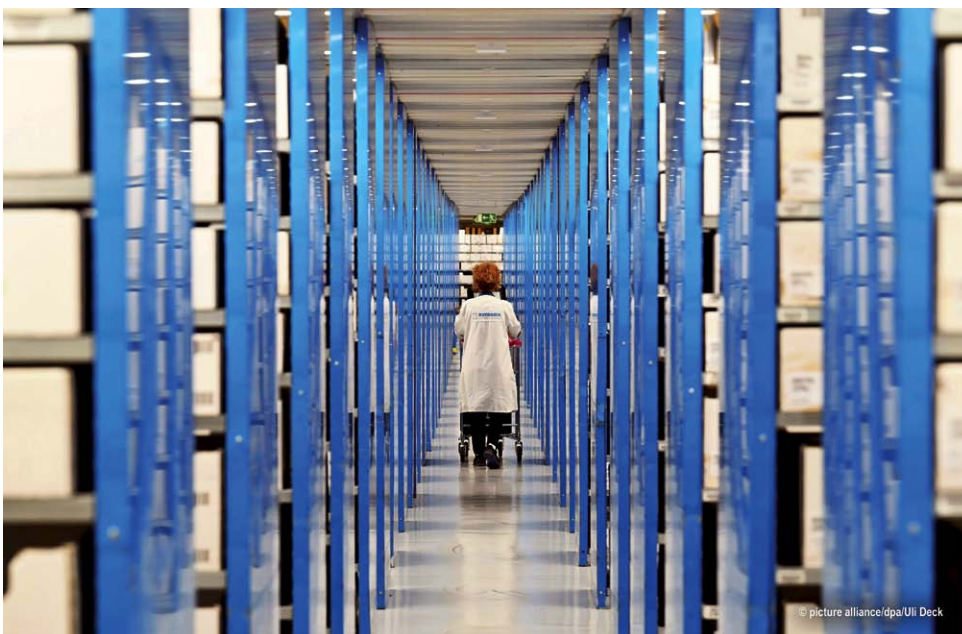

View of a shelf at Rutronik's logistics center in Eisingen



Latest WLAN standard IEEE 802.11be for real-time applications

# Wi-Fi 7 triumphs with 7 features

*Wi-Fi 7 utilizes more efficient frequency bands, multilink operation, and 320 MHz channel width to deliver higher speeds of up to 46 Gbit/s, reduced latency, and enhanced network reliability. Applications with real-time requirements in particular benefit from the performance improvements.*

BY KERSTIN NASER,  
CORPORATE PRODUCT MANAGER WIRELESS  
AT RUTRONIK

Following the release of the Wi-Fi 6 and Wi-Fi 6E standards, the Wi-Fi Alliance introduced the latest IEEE 802.11be standard, also known as Wi-Fi 7, earlier this year. Wi-Fi 7 offers even higher data transmission rates and extremely low latency times. This standard thus meets the requirements for applications like augmented, virtual, and extended reality.

While many users continue to use Wi-Fi 5, Wi-Fi 6 or Wi-Fi 6E have now also gained a strong foothold in the market. Some suppliers already offer Wi-Fi 7-compatible products. The Wi-Fi Alliance projects that by 2028, there will be 2.1 billion Wi-Fi 7-enabled devices available on the market. Routers, smartphones, PCs, and tablets are among the first devices to support [the new standard](#), but



Image: Supatman/stock.adobe.com

Rutronik also already provides solutions for the industrial sector, as detailed in our [Wi-Fi 7 catalogue](#). The Table shows the development and differences of the Wi-Fi standards from Wi-Fi 5 to the latest standard Wi-Fi 7.

The Wi-Fi Alliance identifies key applications for Wi-Fi Certified 7 as multi-user AR/VR/XR, 3D training, gaming, ultra-high-resolution video streaming, hybrid working, Industrial IoT (IIoT), and automotive. However, thanks to the high reliability and speed of data transmission, ultra-precise applications like telediagnosis and telesurgery are also feasible.

The necessary increase in performance results from the following seven features:

**320 MHz channels:** Available in countries that release the 6 GHz frequency band for Wi-Fi. Ultra-wideband channels double the currently widest channel size of 160 MHz for Wi-Fi 6/6E to 320 MHz, also effectively doubling the data transmission rates for individual devices.

	Wi-Fi 5	Wi-Fi 6	Wi-Fi 6E	Wi-Fi 7
Publication	2013	2019	2021	2024
IEEE Standard	802.11 ac	802.11 ax	802.11 ax	802.11 be
Max. PC data rate	~ 1.7 Gbit/s	~ 2.4 Gbit/s	~ 2.4 Gbit/s	~ 5.8 Gbit/s
Max. data rate for access points	~ 7 Gbit/s	~ 9.6 Gbit/s	~ 9.6 Gbit/s	~ 46 Gbit/s
Bands	2.4 and 5 GHz	2.4 and 5 GHz	2.4, 5, and 6 GHz	2.4, 5, and 6 GHz
Channel size	20, 40, 80, 160 MHz	20, 40, 80, 160 MHz	20, 40, 80, 160 MHz	20, 40, 80, 160, 320 MHz
Modulation	256-QAM-QFDMA	1024-QAM-QFDMA	1024-QAM-QFDMA	4096-QAM-QFDMA
MIMO	8x8 MIMO, DL MU-MIMO	8x8 UL/D/MU-MIMO	8x8 UL/D/MU-MIMO	16x16 MU-MIMO
Security	WPA 2	WPA 3	WPA 3	WPA 3

Table 1: Development and differences of the Wi-Fi standards from Wi-Fi 5 to Wi-Fi 7

**Multilink operation (MLO):** With the previous WLAN standards, routers select a single frequency band for data transmission and switch frequency bands only under specific conditions. With Wi-Fi 7, MLO allows devices to simultaneously send and receive data across multiple frequency bands, such as 5 GHz and 6 GHz. This results in higher data throughput, lower delay times, and improved reliability.

**4K QAM:** Wi-Fi 7 enables a higher data transmission rate. This data transmission rate is specified by the modulation technique called quadrature amplitude modulation (QAM). Compared to 1,024 QAM with Wi-Fi 6/6E and only 256 QAM with Wi-Fi 5, 4,096 QAM (or 4K QAM) are possible with Wi-Fi 7. 4K QAM now enables up to 20 percent higher data rates (12 bits instead of 10 bits).

Advertisement

graphene heatsink



### Optional Graphene or Aluminum Heatsink

Transcend offers optional ultra-thin graphene or high performance aluminum heatsink options to improve heat dissipation.

#### Is Heat a Problem in your application?

- Due to PCIe faster data transfer
- Due to smaller applications
- Due to rough environments

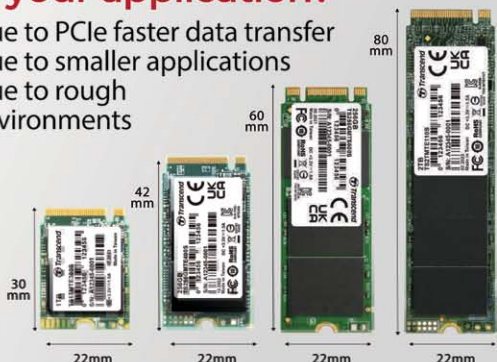

#### Heatsink Test

Try your SSD with Transcend Heat Sink

TS1TMTE712A	Without Heat sink	With Graphene	With Metal
Thickness	3.5mm	3.77mm (+0.22mm)	9.2mm (+5.7mm)
Width	22.0mm	22.0mm	23.1mm (+1.1mm)
Test condition: Room temp. CDM Sequential test			
Normal MB	78°C	74°C (↓4°C)	67°C (↓11°C)



Images: Silex



Wi-Fi 7 M.2 card  
SX-PCEBE from Silex



Wi-Fi 7 SMT version of  
SX-PCEBE from Silex

**512 compressed block acknowledgment:** With Wi-Fi 7, up to 512 data packets (MPDUs – MAC protocol data units) can be sent simultaneously, compared to 256 data packets with Wi-Fi 6. This reduces overheads, thereby enhancing overall efficiency.

**Multiple resource units (RU) to a single station (STA):** Improves flexibility in planning spectrum resources to increase spectrum efficiency. This is achieved because Wi-Fi 7 divides the channel into multiple sub-channels, known as resource units (RUs). This procedure is similar to the OFDMA procedure of Wi-Fi 6. By dividing the channels, interference signals affect only a portion of the WLAN channel rather than the entire channel, as was the case with previous Wi-Fi standards. The remaining part can, therefore, still be used for data transmission.

**Triggered uplink access:** Optimizes the uplink access as defined by Wi-Fi 6 to better handle latency-sensitive streams and meet quality of service (QoS) requirements. The stream classification service (SCS) function prioritizes sensitive data such as games, voice, and video over bulk traffic by "classifying" data.

**Emergency preparedness communication services (EPCS):** Offer users a seamless NSEP (national security and emergency preparedness) service experience while maintaining priority and quality of service (QoS) on Wi-Fi access networks. EPCS enables access points (APs) to communicate with authorized non-AP stations with higher priority.

Applications with real-time requirements benefit from the significantly improved latency. To achieve the theoretical maximum data transmission rate of 46 Gbit/s, WLAN stations with 16 data streams (spatial streams), i.e. also 16 antennas, are required. In practice, this is not practical for small devices like cell phones. For typical home use, routers with fewer antennas are generally

sufficient. However, it definitely makes sense for large companies, smart cities, airports, hotels, etc. with numerous end users.

### First products available

To fully leverage the performance and efficiency of the new standard, products that support Wi-Fi 7 must meet certain requirements. The devices must be equipped with Wi-Fi 7-compatible chipsets that support the new functions and higher speeds. Moreover, the products must also be able to use several frequency bands at the same time to enhance network performance. In addition, support for 4,096 QAM is required for higher data density and efficiency. Rutronik already offers Wi-Fi 7-capable routers, mainboards, expansion cards, industrial modules, and laptops.

Intel's BE200 and BE202 modules fully support the benefits of the new wireless standard, above all low latency times, high reliability, and high speeds: BE202 enables 2.4 Gbit/s with 2 x 2 TX/RX streams, BE200 even 5.8 Gbit/s. Both solutions also support the Bluetooth 5.4 standard. Additionally, these modules are pre-certified globally, resulting in significant cost savings for customers. However, VPRO support is currently only possible for BE200. Versions for the industrial temperature range or embedded applications are also not yet available. Both cards can be obtained in the M.2 2230 and M.2 1216 form factors.

Silex has also announced a Wi-Fi 7 platform with SX-PCEBE. Like Intel's products, the SX-PCEBE plug-in card will also be on offer in two form factors, as an M.2 2230 plug-in board and as an SMD M.2 LGA type 1620. In addition to Wi-Fi 7, the module also supports Bluetooth 5.3, is based on the Qualcomm QCC2076 chipset and features an operating temperature range of  $-40^{\circ}\text{C}$  to  $+85^{\circ}\text{C}$ . The first samples of this module are expected by the end of 2024, with series production planned for the first quarter of 2025.

Besides the plug-in card solutions mentioned, Rutronik already offers complete Wi-Fi 7 routers and mainboards from Asus, as well as special avionics routers from Advantech. Wi-Fi 7 chips from MediaTek are now available for expert developers and high-volume projects. Suitable Wi-Fi 7 antennas from 2J and Kyocera AVX can also be obtained from Rutronik.

### Summary

Like Wi-Fi 6E, Wi-Fi 7 supports the 6 GHz frequency band – an advantage, as the 2.4 GHz frequency band is also used by other technologies such as Bluetooth, ZigBee, and Thread. However, keep in mind that higher frequencies also result in shorter ranges. To ensure comprehensive WLAN availability, it may therefore be necessary to increase the number of access points.

Despite the backward compatibility of Wi-Fi 7 with previous standards, not only the routers but also the end devices must support Wi-Fi 7 to fully leverage the benefits of Wi-Fi 7. ■



Scan the QR code for more information about Wi-Fi 7 and the product solutions in the [Wi-Fi 7 catalogue from Rutronik](#)



5G RedCap – ideal combination of low costs and improved efficiency

# More than just a 4G LTE substitute

*5G RedCap technology is designed to bridge the gap between energy-saving and ultra-fast networks, opening the door to a new generation of IoT devices. Discover how this technology is revolutionizing the 5G ecosystem and propelling IoT applications to a whole new level.*

BY LUISA LETZGUS,  
CORPORATE PRODUCT MANAGER WIRELESS  
AT RUTRONIK

**L**TE (long term evolution) is a well-established wireless communications standard that reliably supports a wide range of everyday applications that require medium data rates. However, for applications that demand high speeds or place specific requirements, 5G may be the more suitable option. For instance, 5G provides substantially higher bandwidth and lower latency, allowing for faster data transmission and near real-time communication. This is crucial to support various applications, including augmented reality (AR), virtual reality (VR), autonomous driving, and the Internet of Things (IoT). 5G provides numerous benefits in terms of speed, capacity, and latency, but it also introduces a significant level of complexity.

5G RedCap, also referred to as 5G NR-Light, is designed specifically for IoT broadband devices such as wearables, video surveillance systems and industrial sensors that need higher data throughput and transmission rates, along with lower latency. In terms of its performance, this positions 5G RedCap between the highly developed 5G application

profiles (eMBB and uRLLC) and the energy-efficient IoT technologies (LTE-M and NB-IoT). 5G RedCap is ideal for applications currently based on LTE Cat 1 or Cat 4.

According to Omdia, 5G RedCap modules will constitute 18 percent of total cellular module shipments by 2030. This is just perfect for IoT applications that do not demand ultra-low latency but still require a sufficient amount of data throughput, with the technology providing an optimum blend of cost-effectiveness, performance, and energy efficiency. Furthermore, 5G RedCap is the first 5G technology to offer energy-saving functions (RRM relaxation, DRX). The Table shows the specifications and differences between LTE, 5G, and 5G RedCap.

### Advantages of 5G-based technologies

The number of networked devices and the amount of data in our digital world are continuously growing. Network capacity is therefore becoming increasingly important. Thanks to the increased network capacity of 5G and 5G RedCap, more devices can be connected simultaneously without any loss of performance. This enables seamless connectivity in environments with a high density of networked devices, for example in smart cities, Industry 4.0 applications, or at major events.

The faster data rates and substantially increased bandwidth of 5G and 5G RedCap provide numerous additional benefits for both businesses and end users. For instance, large files can be downloaded in a matter of seconds or high-resolution videos can be streamed without delay. This enables smooth performance for applications like AR, VR, and cloud gaming.

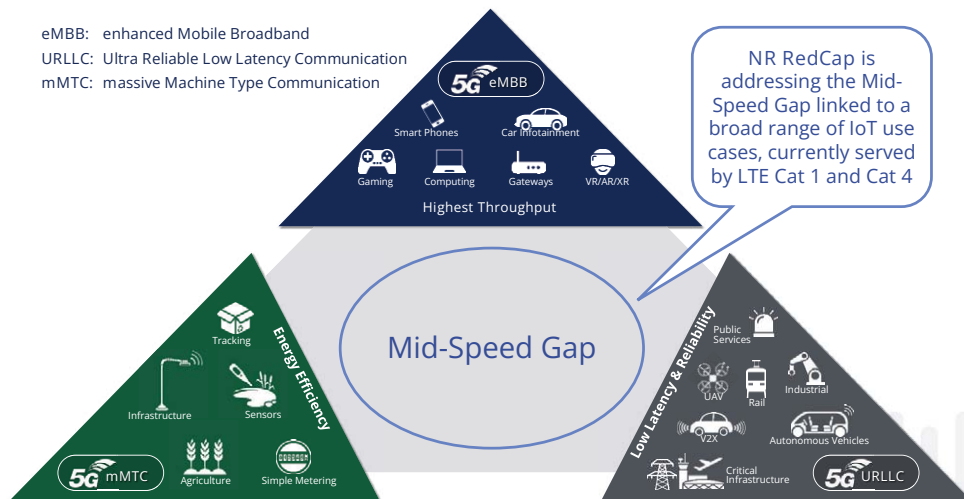

The first generation of 5G IoT services have left a gap in the mid-speed range. NR RedCap fills this gap alongside a range of IoT use cases currently served by LTE Cat 1 and Cat 4.

Images: Telit, Cinterion



Properties	LTE Cat 1	LTE Cat 4	5G	5G RedCap Rel 17
Frequency	B1, B3, B7, B8, B20, B28A	B1, B3, B7, B8, B20, B28A	5G FR1 and FR2	5G FR1
Bandwidth	up to 20 MHz	up to 20 MHz	20 MHz+, up to 120 MHz, 200 MHz	FR1 – 20 MHz
Data rate	10 Mbit/s DL 5 Mbit/s UL	150 Mbit/s DL 50 Mbit/s UL	5G NSA: 4.9 Gbit/s DL, 0.55 Gbit/s UL 5G SA: 4.1 Gbit/s DL, 0.90 Gbit/s UL	150 Mbit/s DL 50 Mbit/s UL up to 220/100 Mbit/s
Latency	50–100 ms	50–100 ms	URLLC 1 ms	Application-dependent latency
Energy consumption	Lower (PSM and eDRX possible)	Higher	High	Power-Saving: PSM, RRM relaxation and eDRX support in idle and restricted to 10,24S
Network infrastructure	All-LTE network	All-LTE network	5G SA and NSA	5G Standalone (SA) (1st-gen RedCap modules also support LTE fallback)
Areas of application	Voice, data and mobile applications, security panels, telematics, asset tracking, smart grids, smart city solutions, wearables for health and fitness monitoring, smart homes and buildings, smart waste disposal	Mid-tier routers and gateways, video cameras	Industrial gateways and enterprise routers, SD-WAN, fixed wireless access, professional 4K/8K video, factory automation, cloud gaming	Mid-tier routers and gateways, video cameras, wearables

Comparison of LTE, 5G, and 5G RedCap

Reduced latency allows for more efficient bandwidth usage and minimizes network congestion. This results in a more stable and reliable data transmission overall. Real-time information transmission will also be possible, which is crucial for applications in the fields of autonomous driving, telemedicine, and industrial automation.

5G RedCap offers additional functions that have been specially developed for industrial applications. This includes network slicing, a functionality that allows a single network to be divided into multiple virtual networks to support various applications with specific requirements. Further, 5G RedCap offers improved security functions and better integration of IoT devices into the network. Compared to current LTE standards, RedCap will enhance performance, particularly in the uplink, which is vital for router-gateway applications, while also boosting efficiency, which is essential for battery-powered devices like cameras and telematics units. RedCap devices profit from the capabilities of 5G implementations, while utilizing only a subset of its features to strike a perfect balance between functionality, cost, and power consumption. Typical RedCap devices are wearables, sensors, monitoring systems, and other IoT devices.

*Variety of applications from wearables to AI*

The IoT refers to the networking of physical devices and objects that are able to commu-

nicate with each other through the Internet. 5G enables the connection and control of a large number of IoT devices in real time. This allows smart devices, such as wearables and connected vehicles, to be effortlessly integrated into our day-to-day lives. The 5G RedCap system is a key module in this process. It offers a platform for efficient resource and energy management in IoT networks. IoT devices can be managed more intelligently to enhance energy efficiency and prolong battery life.

The rollout of 5G networks is set to enhance the efficiency and sustainability of not just smart homes but entire cities. Sensors and IoT devices monitor and optimize various aspects of urban life, including traffic, energy consumption, waste management, and public safety. The 5G RedCap system facilitates the

integration and management of a range of services and applications on a common platform. This allows towns and cities to utilize resources more efficiently and to improve the quality of life of their residents by making informed decisions.

Industrial automation involves the use of technologies like sensors, actuators, and control systems to automate industrial processes and systems. And, with 5G, these processes can become even more efficient and flexible. Fast and reliable data transmission facilitates the real-time transmission of large volumes of data, thereby enabling the more precise control and monitoring of machines and systems. When employing RedCap, businesses can further optimize their production processes, reduce energy consumption, and slash operating costs.



FE910C04 (left) and FN920C04 (right) enable 5G mid-speed connectivity relying on the latest 3GPP Release 17 RedCap technology and are industrial grade, rugged, suitable for global use, and equipped with enhanced uplink performance, power-saving features, and LTE Cat 4 fallback for best coverage.

The RedCap system is also a key component of the 5G infrastructure in the increasingly important fields of artificial intelligence (AI) and robotics. This is where the system provides a platform for efficient resource and energy management. In fact, the reliable transmission of large volumes of data in real time enhances the response times of AI systems, making interactions with robots more efficient.

---

*Summary*

---

By combining 5G and 5G RedCap, businesses can create innovative solutions for Industry 4.0 applications that demand robust and dependable wireless connectivity. These technologies also enable them to enhance their production processes, boost efficiency, and

unlock new business opportunities. And that's not all: Another version of 5G RedCap, eRedCap (enhanced RedCap), is currently under development and will be launched in 3GPP Release 18. With a data throughput rate of 10 Mbit/s or 5 Mbit/s (DL/UL), respectively, it offers additional energy-saving potential. The HF bandwidth is set to remain at 20 MHz. Commercial availability is expected in 2026. Thanks to innovations in the IoT segment, 5G eRedCap modules are expected to constitute 18 percent of total cellular module shipments by 2030. ■



These data cards (FN990A40/A28, FN990A40-HP/A28-HP, LTE/5G data card) form the basis for IoT, enterprise applications, and video. They provide immediate access to the advantages of 5G and gigabit LTE.

Advertisement



## **MX81 SERIES COMPACT CONNECTORS**

- Tab size: 0.64mm
- Terminal pitch: 2.54mm
- Common terminal with MX80 series
- High current carrying capability
- Extensive wire range from 0.13 to 1.0sq
- Designed for small spaces with small panel feed-through holes
- One piece design with hinged TPA feature and competitive price





Precise positioning and high-speed transmission

# UWB today and in the future

*Ultra-wideband technology has become an important wireless communication technology with a wide range of applications. As development and distribution advance, ultra-wideband technology will be pivotal in the next generation of wireless communication and positioning.*

BY TORSTEN KILLINGER,  
CORPORATE PRODUCT MANAGER WIRELESS  
AT RUTRONIK

Ultra-wideband (UWB) is a wireless communication technology that has been evolving since the early 2000s, and has seen significant advancements in recent years. Originally used for military applications and the development of radar equipment, UWB has also conquered the commercial market due to its ability for precise localization and high-speed transmission, and has developed into an important wireless communication technology offering a wide range of applications.

Various standards developed by the IEEE, the WiMedia Alliance, or the ECMA define the basic specifications and protocols essential for operating UWB in different applications. They ensure interoperability between different UWB devices, and enable the development and implementation of high-perfor-

mance, reliable wireless communication systems.

## *Differentiation from other methods and position measurement*

With a bandwidth of at least 500 MHz (or 20 percent of the average carrier frequency), UWB offers a data transmission rate that is at least an order of magnitude higher than those of other wireless technologies, such as Wi-Fi (20, 40, 80, 160, and 320 (be) MHz) and Bluetooth (1 or 2 MHz). UWB uses a very wide frequency range, typically covering several GHz (3.1 to 10.6 GHz). Like Wi-Fi, UWB also utilizes multiple overlapping channels. Another key difference from other wireless transmission methods is that UWB systems can operate at lower power levels. This is de-



Image: Murata



fined by the spectral density, i.e. the transmitted power per MHz bandwidth. In contrast to narrowband wireless technologies, UWB transmits at levels close to the noise limit. Another difference is that UWB can use different types of data coding (Fig. 1).

The features specified above enable UWB to deliver highly accurate and precise position information. Typically, time of flight (ToF) and angle of arrival (AoA) are combined between end devices such as UWB-enabled smartphones or industrial UWB anchors, and UWB tags as positioning methods using wireless UWB communication.

Two-way ranging (TWR) measures the time it takes for a signal to travel from a transmitter (UWB tag) to a receiver (anchor) and back. This method is particularly accurate, as it relies on direct time measurements and effectively handles multipath effects (reflections). Two TWR methods exist: single-sided two-way ranging (SS-TWR) uses two distance measurements, while double-sided two-way ranging (DS-TWR) uses three distance measurements. The additional measurement with DS-TWR makes the measurement more accurate.

Time difference of arrival (TDoA) determines the transmitter's position by measuring the time difference at which a signal arrives at multiple receivers. TDoA is particularly effective in environments with multiple reception points, and enables real-time positioning of moving objects.

### *Integration options in existing networks*

Integrating UWB into existing networks such as Wi-Fi or other wireless networks requires meticulous planning and coordination to guarantee seamless interoperability among the technologies. Compliance with standards like IEEE 802.15.4z ensures that UWB devices from different suppliers are compatible with each other and can be seamlessly integrated into existing networks. UWB can co-exist with other wireless technologies, e.g. Wi-Fi and Bluetooth, without interfering with them.

Given that UWB and Wi-Fi can be operated in the same frequency range, effective interference management is crucial. Collision avoidance and handling protocols need to be developed to make sure that both technologies work efficiently and reliably. This can be achieved through time-division multiplexing, frequency selection, or other coexistence mechanisms. UWB can be used as a supplement to existing localization technologies such as Wi-Fi or Bluetooth Low Energy. By integrating UWB with these technologies, hybrid positioning systems can be created, which enhance both accuracy and reliability. For instance, UWB can provide precise indoor localization, while Wi-Fi or Bluetooth Low Energy can be leveraged for broader connectivity and outdoor localization. In environments where cabling is difficult or costly, Wi-Fi networks can be easily extended or

improved. To achieve this, UWB can serve as a wireless backhaul connection, eliminating the need for additional cabling. In mesh networks with multiple interconnected nodes, UWB can be used to improve node localization and connectivity. This can enhance the reliability and overall performance of the mesh network, particularly in environments with numerous obstacles or moving objects.

### *Indoor positioning, healthcare and smart home*

UWB offers a wide range of applications and use cases in both the commercial and the industrial sector. Especially when it comes to indoor positioning, UWB stands out from other technologies. The reasons for this include the high positioning accuracy within the centimetre range, the lower susceptibility to interference, and the UWB's ability to effectively handle multipath effects caused by reflections indoors. Examples of UWB products include the Apple iPhone 11 and higher, as well as vehicles from car manufacturers like VW, Audi, and Cupra, which use UWB in their vehicles to enhance the security of keyless go systems.

Murata currently offers three ultra-wideband (UWB) modules on the market, with three more planned for 2024/2025. Type 2AB (Fig. 2) is a compact UWB + Bluetooth Low Energy module that is suitable for many applications requiring precise detection. Thanks to the in-

Advertisement

**RECOM: THE #1 POWER SUPPLY MANUFACTURER FOR RUTRONIK**  
**A SUCCESSFUL PARTNERSHIP FOR MORE THAN 30 YEARS**

Together we guarantee innovation and excellence in power supply design.

**ANNIVERSARY**  
CELEBRATION



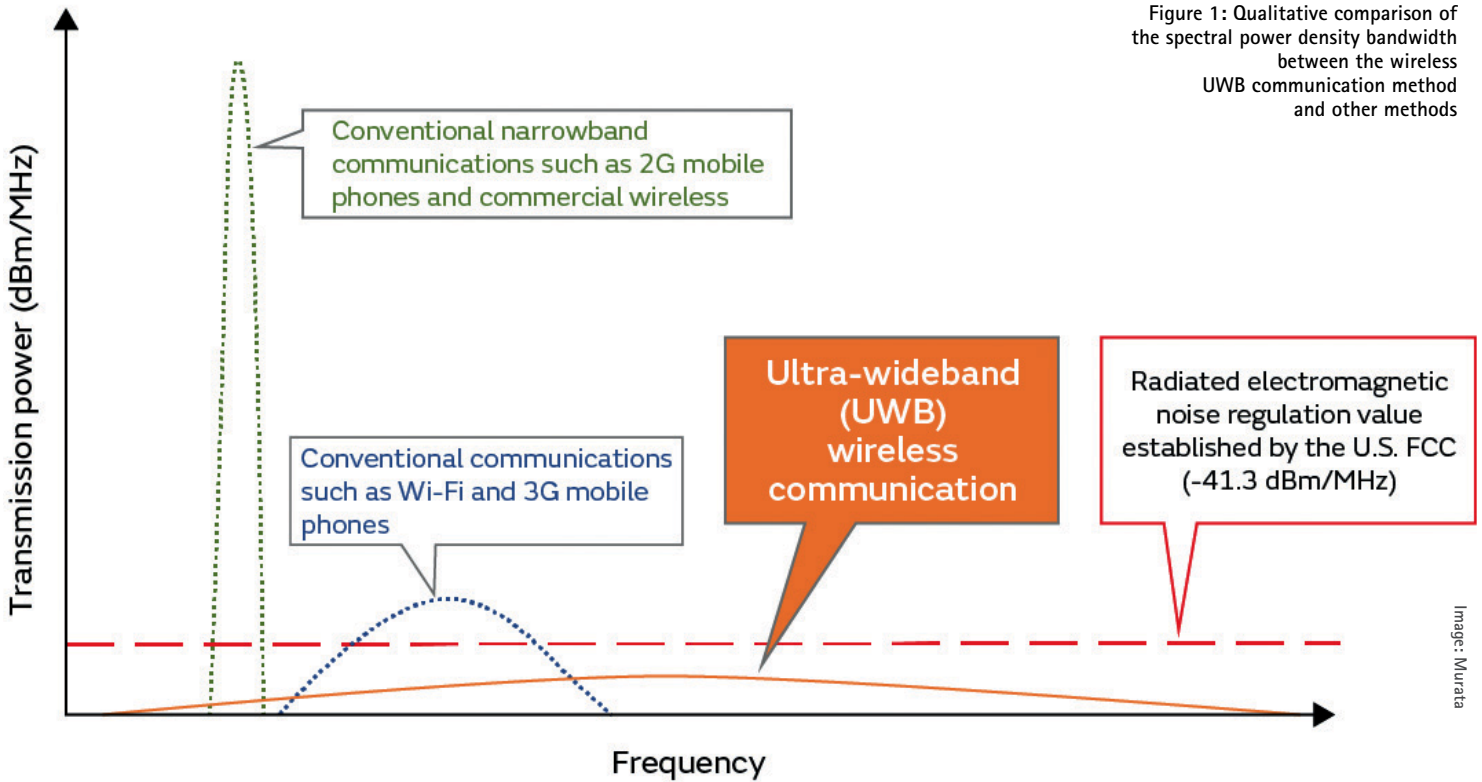

Figure 1: Qualitative comparison of the spectral power density bandwidth between the wireless UWB communication method and other methods

Image: Murata

egrated Qorvo IC QM33120W, the mounting area can be reduced by 75 percent compared to chip-on-board designs. In addition, the UWB module with a Nordic Semiconductor nRF52840 offers improved design flexibility and shorter product development times, as customers can draw on a pool of Nordic source codes and use the module for other wireless tasks at the same time. The module also comes with 256 kB RAM, 1 MB flash, and a 3-axis sensor for motion detection. Up to three antennas can be used for the system-in-package module – two antennas for UWB and one for Bluetooth Low Energy.

Type 2DK, based on the NXP Trimension SR040 and NXP QN9090, is a complete solution designed for battery-operated applications with low power consumption. With its integrated

640 KB flash and 152 KB SRAM, Type 2DK provides ample resources to host UWB functions, aiding OEMs in developing their applications. The combination of UWB and Bluetooth Low Energy makes it ideal for UWB tags and trackers. The entire PHY/MAC operation is handled within the UWB IC according to FiRa Consortium specifications in order to shorten the time to market.

Type 2BP is suitable for UWB activation of larger infrastructures like access control, indoor positioning anchors, and payment terminals, as well as consumer products such as televisions and gaming consoles. The technology enhances distance measurement and 3D-AoA (angle of arrival) with various antenna configurations, offering improved reliability and accuracy. The integrated PHYs and MACs comply with the FiRa specifications and ensure interoperability with an ever-growing number of UWB devices.

ISP3080 from Insight SiP (Fig. 3) is a highly miniaturized LGA module (12 x 12 x 1.5 mm) based on the QM33110 UWB transceiver from Qorvo and the nRF52833 Bluetooth Low Energy chip from Nordic Semiconductor. Using a simple user interface via the SPI connection and integrating a Cortex M4 CPU, flash memory, and RAM combined with optimized antennas, ISP3080 offers a stand-alone solution for RTLS, access control, and indoor positioning applications. The modules also include a 3D accelerometer to allow for energy-saving

modes with wake-up dictated by movement. ISP3080 sets itself apart by integrating a multiband antenna into the package that supports both the Bluetooth Low Energy frequency band at 2.4 GHz and the UWB frequency band at 6.5/8.0 GHz. This is a novel concept developed by Insight SiP within an SiP package. UWB communication conforms to IEEE 802.15.4. ISP3080 offers precise localization with a simple user interface controlled wirelessly via Bluetooth.

For long-range applications, typically extending several hundred metres, ISP3080 can be paired with an external UWB antenna. Bluetooth Low Energy connectivity is compatible with Bluetooth 5.1, and enables long-distance position finding and functions via Bluetooth.



Figure 2: Type 2AB is a compact UWB + Bluetooth Low Energy module that is suitable for many applications requiring precise detection.

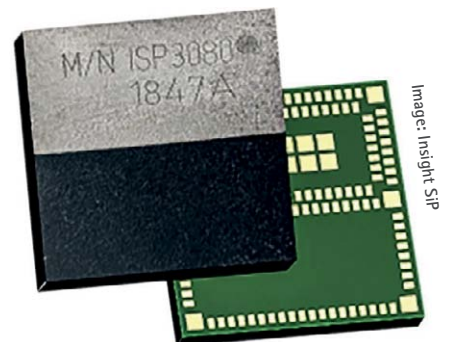

Figure 3: ISP3080 is a stand-alone solution for RTLS, access control, and indoor positioning applications.

UWB sensors and tags can be integrated into industrial networks to enable real-time tracking and automation. MS01SF1 (Fig. 4) from MinewSemi is an ultra-wideband (UWB) and Bluetooth Low Energy 5.2 module integrated with the latest Qorvo DW3120 SoC for indoor positioning and the Nordic Semiconductor nRF52833 SoC as the central processor. It supports Bluetooth Low Energy and NFC connectivity as well as other protocols, including Thread/ZigBee/IEEE 802.15.4. This module can be used in a variety of UWB applications such as warehousing and logistics, as well as for security and access control. It offers two-way distance measurement (TWR) and positioning systems (TDoA) for localizing assets with an

accuracy of 10 cm while supporting data rates of up to 6.8 Mbit/s.

*Summary*

UWB is a future technology poised to revolutionize numerous applications with its precise localization capabilities and high data transmission rates. Integration into existing networks is facilitated by standardized protocols, compatible hardware, and supporting software. As development and distribution advance, UWB will be pivotal in the next generation of wireless communication and positioning.

Image: Minew

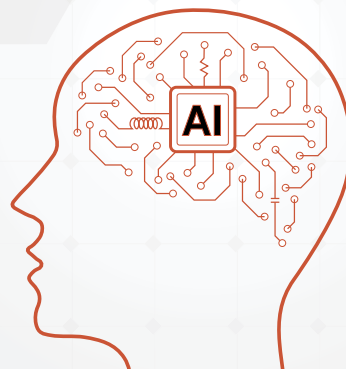

Figure 4: MS01SF1 can be used in a variety of UWB applications such as warehousing and logistics, as well as for security and access control. It offers TWR and TDoA for localizing assets with an accuracy of 10 cm while supporting data rates of up to 6.8 Mbit/s

Advertisement

YAGEO Group stands at the forefront, embedded in the very fabric of AI technology. Our components are not just parts; they are the backbone of the AI revolution, enhancing the power density and operational efficiency of the critical infrastructure that powers AI.

<b>CAPACITORS</b>	<b>INDUCTORS</b>	<b>RESISTORS</b>	<b>CIRCUIT PROTECTION</b>	<b>SENSORS</b>
<b>CONNECTORS &amp; ICMS</b>	<b>ANTENNAS &amp; RF COMPONENTS</b>	<b>EMC</b>	<b>MOSFETS</b>	<b>PIEZOELECTRIC DEVICES</b>



**YAGEO** GROUP  
Built into Tomorrow, Built into AI.



DECT NR+ – the first non-cellular 5G standard worldwide

# The missing puzzle piece in IoT

*DECT NR+ fills a significant gap in wireless connectivity by providing a reliable, standardized communication protocol with an unparalleled combination of low latency, long range, high data rates, no duty cycle limitations, and near-global frequency coverage – all at a low cost. This makes it a true alternative to other wireless technologies.*



Image: metamorworks/Shutterstock

BY JULIAN CLAUSS, CORPORATE PRODUCT  
MANAGER WIRELESS AT RUTRONIK

**T**oday, millions of devices, machines, sensors, and all kinds of vehicles are connected via the Internet of Things (IoT). Despite the wide range of wireless technologies now available, some network scenarios were previously not possible with existing wireless standards due to high costs and their vulnerability to interference. The introduction of DECT NR+ (New Radio Plus) fills this gap in the IoT ecosystem. DECT NR+ is the first and only non-cellular 5G technology standard worldwide.

*From cordless telephony  
to industrial automation*

DECT (Digital Enhanced Cordless Telecommunications) was unveiled in 1992 and intro-

duced a year later. DECT is currently recognized primarily as a standard for cordless telephony and smart home devices and is overseen by ETSI (European Telecommunications Standards Institute), an independent, non-profit organization dedicated to standardization in the field of information and communication technologies. The frequency is now also becoming interesting for very different applications.

DECT, which originated in Europe, has become the most widely used standard for cordless phones, replacing older analog ones that operated on the CT1 and CT2 bands, which are now prohibited for end users. Further, DECT has been introduced outside of Europe, with various versions implemented in Australia, much of Asia, South America, and more recently in North America.

DECT was originally developed for fast roaming between networked base stations. Besides cordless phones that communicate with a landline base station, heating valves, sockets, or light switches can also establish a wireless connection to certain routers thanks to ULE with HAN-FUN standards based on DECT technology.

Over the years, DECT has been further developed with several new variants and new audio codecs. Nearly 30 years later, DECT-2020 NR was approved by the International Telecommunication Union (ITU) for the IMT-2020 (= 5G) standard. The new protocol is now referred to as NR+ (New Radio Plus) by the DECT Forum.

.....  
*What is 5G and which role does DECT NR+ play?*  
.....

In telecommunications, 5G represents the fifth-generation technology standard for cellular networks. It divides the coverage area into smaller geographical zones called cells, which are served by transmission towers. The

benefits of 5G compared to previous generations include faster data rates, lower latency, real-time transmission, and the ability to address more devices simultaneously within the network. To this end, the 5G standard is divided into three service categories that require varying characteristics:

**Extreme mobile broadband (eMBB)** applications primarily target solutions requiring high bandwidth, optimizing cellular devices and enabling fixed wireless access such as mobile UHD video streaming, high-speed downloads, and applications in areas like augmented reality (AR) and virtual reality (VR).

**Massive machine type communications (mMTC)** support the massive connectivity of devices in IoT applications. This area should prioritize maximizing the number of possible connections while ensuring low data rates and minimizing energy consumption. To accommodate the high number of connections in a network, collision-free transmission must be ensured. A typical application would be full soccer stadiums or major events with sev-

eral thousand end device users where only one cell phone tower is needed thanks to 5G.

**Ultra-reliable low latency communication (URLLC)** is the third key 5G function that enables reliable connections with low latency. In critical applications, it is essential to guarantee robust, fail-safe communication with minimal delays. For example, URLLC is essential for applications such as autonomous driving, precision agriculture, time-critical industrial automation, and critical infrastructures of utility companies.

Within the 5G spectrum, DECT NR+ addresses mMTC and URLLC, offering highly scalable, reliable communication with low latency and extended ranges. This makes DECT NR+ particularly attractive for applications that require mMTC and/or URLLC (Fig. 1). IPv6 addressing enables the potential to reach every subscriber worldwide.

Unlike many other wireless standards, DECT NR+ is specially designed for industrial use. Its uniqueness lies in the blend of proven technologies tailored to Industry 4.0 require-

Advertisement



# Circuit Protection Solutions for Battery Energy Storage





## The 5G triangle (IMT-2020)

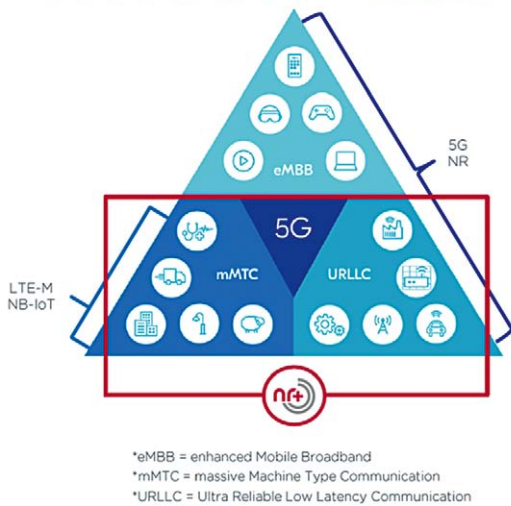

Figure 1: Diagram of the 5G triangle. DECT NR+ complements mMTC and URLLC as a cost-effective, energy-efficient, and flexible communication solution in license-free frequency bands

ments, including scalability, robustness, standardization, and operation in license-free frequency bands.

### How does DECT NR+ work and what are its special features?

DECT NR+ supports the three network topologies point-to-point, star, and mesh and is, therefore, a flexible standard to meet various application requirements. A key feature of the NR+ mesh network is its self-healing and self-organizing properties. Each node can serve as an access point with a direct connection to the Internet: Should a node in the mesh network fail, the data are automatically routed via neighboring nodes. This feature eliminates single points of failure within the network and automatically resolves issues like device failures caused by defects, maintenance, or restructuring, which frequently occur in dense IoT networks, all without the need for human intervention or a central operator.

NR+ delivers the same low latency and high reliability once exclusive to wired connections or third-party managed and fee-based cellular networks. For the first time, low-latency systems can operate wirelessly over many kilometers at speeds of several megabits per second. Further, the technology is highly scalable, supporting up to one million nodes per square kilometer within a single network.

DECT NR+ operates on the 1.9 GHz band, which can be utilized (almost) everywhere in

Figure 2: The first products that support the DECT NR+ protocol



#### nRF9161 SiP

Low power SiP for cellular IoT and DECT NR+

Multimode LTE-M/NB-IoT with GNSS and DECT NR+ modem  
 700-2200 MHz LTE band support  
 1.9 GHz NR+ band support  
 Certified for global operation  
**Dedicated application processor and memory**  
 64 MHz Arm Cortex-M33  
 1 MB flash + 256 KB RAM  
 Arm TrustZone + Arm CryptoCell



#### nRF9151 SiP

Low power SiP for cellular IoT and DECT NR+

Multimode LTE-M/NB-IoT with GNSS and DECT NR+ modem  
 700-2200 MHz LTE band support  
 1.9 GHz NR+ band support  
 Certified for global operation  
**Dedicated application processor and memory**  
 64 MHz Arm Cortex-M33  
 1 MB flash + 256 KB RAM  
 Arm TrustZone + Arm CryptoCell



#### nRF9131 mini SiP

Low power mini SiP for cellular IoT and DECT NR+

Multimode LTE-M/NB-IoT with GNSS and DECT NR+ modem  
 700-2200 MHz LTE band support  
 1.9 GHz NR+ band support  
 Certified for global operation  
**Dedicated application processor and memory**  
 64 MHz Arm Cortex-M33  
 1 MB flash + 256 KB RAM  
 Arm TrustZone + Arm CryptoCell

Images: Nordic Semiconductor

the world. It is less prone to interference compared to traditional ISM and SRD frequency bands and can be used without a license and fee, unlike cellular frequencies, which mobile network operators (MNOs) acquired for a significant price through auctions. NR+ can be used to set up a private network that is independent of cellular networks or SIM cards. This helps to avoid high license fees or overcome regulatory hurdles. Safety-critical environments benefit from a fully independent and locally controllable network.

The standard was developed with energy efficiency in mind, a crucial factor especially for battery-powered IoT devices. Thanks to efficient transmission and reception protocols and compression algorithms, the devices can operate for several years, depending on the battery capacity and communication volume.

### DECT NR+ compared to other equivalent technologies

DECT NR+, LoRa, Sigfox, Mioty, LTE-M, or NB-IoT: Each technology has its own characteristics, advantages, and areas of application.

SigFox, Mioty, and LoRa are all part of the low-power wide-area network (LPWAN). In this area, data can be transmitted over many kilometers with low energy consumption, but also at a lower data transmission rate. SigFox, Mioty, and LoRa have all been on the market for a number of years and are, therefore, known for their limitations. While SigFox failed to establish a comprehensive infra-

structure and has faded from prominence over time, Mioty and LoRa users are required to construct their own networks. For instance, some towns and cities have already set up their own LoRaWAN network to connect data-saving sensors to the Internet. All three LPWANs utilize the publicly available and license-free sub-GHz frequency range. However, as the free frequencies are accessible to everyone and used by countless other wireless applications, a high volume of signals may result in interference. Moreover, there are also significant restrictions when it comes to use. A device is restricted to transmitting no more than one percent of the time, which can pose challenges for routers when having to send acknowledge messages to thousands of sensors in a short space of time. This also makes it practically impossible to transfer firmware updates.

Yet another disadvantage of technologies based on the sub-GHz band is regional limitation. Devices produced for Europe are expected to use the 868 MHz SRD band, while 915 MHz is available in the USA, and other frequency ranges are applied in Japan and other parts of the world. Devices made with NR+ operate on the same frequency globally, allowing for a single certification process. This means antenna performance only needs to be calibrated once and component logistics can be streamlined under certain conditions.

In contrast to license-free LPWANs, LTE-M and NB-IoT use the licensed spectrum assigned exclusively to MNOs. The two standardized wireless technologies benefit from

the already extensive global network coverage. Compared to LTE-M, NB-IoT excels in terms of energy efficiency and building penetration, but it comes with notably lower data rates and higher latency and lacks the ability to switch cells during an active transmission. LTE-M in contrast constructs a bridge between LTE and NB-IoT: LTE-M was developed specifically for IoT solutions that would otherwise be too large and too energy-intensive for LTE and would not offer the required mobility and bandwidth for NB-IoT.

The trend towards increasingly networked IoT devices worldwide not only places significant demands on the infrastructure but also heightens the need for cost-effective and reliable solutions that prioritize low energy consumption. Compared to other LPWAN wireless technologies, DECT NR+ boasts an impressive compromise between range and latency combined with low energy consumption. Notably, DECT NR+ offers exceptional scalability, high data rates in the license-free 1.9 GHz frequency band, and operates independently of cellular network providers and

SIM cards, thereby resulting in significant cost savings and making it a highly interesting new alternative.

The Table on page 64 provides an overview of the various technologies.

#### *Application examples*

DECT NR+ can be interesting as a cost-effective alternative to existing solutions and opens up possibilities for applications that have yet to be implemented. NR+ is, therefore, particularly suitable for industrial IoT applications, smart metering, smart cities and professional audio applications.

DECT NR+ offers unique features that play a key role in modern day Industrial IoT (IIoT) and Industry 4.0. The dense network topology of NR+ accommodates an exceptionally high number of nodes, making it ideal for large-scale operations. Real-time communication between various devices and machines as well as a self-organizing and self-healing

mesh topology are crucial for the automation and optimization of production processes.

Smart cities will help to lower carbon dioxide emissions through various applications, including traffic management, locating parking spaces, optimizing waste collection, enhancing street lighting, and improving energy storage, plus much more. All these applications require solutions for remote monitoring and controlling that are connected to various control centers via a network. NR+ was designed to support highly reliable and powerful wireless mesh networks, making this extremely scalable communication both feasible and practical. It also enables additional applications, such as audio transmissions in urban areas and the connection of stationary surveillance cameras or even mobile ones in public transport vehicles. Small urban centers – like airports, campuses, and shopping malls – often have a high concentration of varying use cases that demand a low-latency, high-data-traffic and reliable network, and these settings would greatly benefit from a private and cost-effective DECT NR+ network.

Advertisement

## G9KC PCB POWER RELAY

### RETHINK EFFICIENCY FOR YOUR WALLBOX PRODUCTS

Our G9KC relay revolutionizes the AC wallbox with new levels of energy efficiency and durability. This 480VAC 40A 4-pole high power relay offers low and stable contact, making it perfect for your most demanding wallbox designs.

- 4a double-break, mechanically coupled main contact
- Low contact resistance
- 1b Aux. contact option complies with IEC 60947-4-1
- High short circuit compliance (IEC62955:2018)
- Developed to the highest Japanese design standards



# OMRON



Scan the QR code for more information

[www.components.omron.com/eu](http://www.components.omron.com/eu)



The smart energy market is already well-established and will certainly continue to grow. A key benefit of NR+ is that it offers a standardized alternative to those proprietary solutions already in use. Its mesh network topology also enables the connection of various local clusters, thereby increasing the overall range. By utilizing the license-free global 1.9 GHz frequency band, DECT NR+ allows for a standardized solution that can be implemented worldwide at optimized low costs. DECT NR+ can therefore be employed in smart meters, for example to record energy and water consumption data in real time and to transmit them to various utility companies. Besides transmitting consumption data, bidirectional communication also enables the remote control of meters and devices such as for the remote-controlled switch-off of smart washing machines or for sending information about tariff changes to household consumers.

Wireless microphones and audio transmission systems also profit from the new technology. DECT NR+ offers stable, interference-free transmission with low latency, which is absolutely essential in live environments. Especially at large events in extensive areas, such as concerts, festivals, or soccer stadiums, it is possible to transmit undisturbed on the 1.9 GHz frequency band, independent of many 2.4 GHz interference sources (Bluetooth, Wi-Fi).

*First products with DECT NR+ available*

Nordic Semiconductor is currently the only supplier on the market that supports the DECT NR+ protocol and already offers its own DECT

NR+ compatible modules. The mesh software is obtained from the Finnish third-party provider Wirepas and the audio software from Lynq.

Nordic Semiconductor currently offers three DECT NR+-capable products in the nRF91 series: nRF9161 SiP, nRF9151 SiP, and nRF9131 mini SiP.

nRF9151 is a highly integrated and compact system-in-package (SiP) solution specifically designed for cellular IoT and DECT NR+ applications. Through the use of power-saving LTE technology, advanced processing capabilities, and robust security features, nRF9151 offers high performance and versatility and supports 3GPP Release 14 LTE-M/NB-IoT and DECT NR+.

All three modules are equipped with a powerful ARM Cortex-M33 processor, which manages processing of the communication protocol and the customer application and, therefore, does not require any additional microcontrollers in the end devices. To select the best possible and most energy-efficient communication for its application, all the modules support LTE-M, NB-IoT, and GNSS positioning in addition to DECT NR+. All three variants are almost identical in terms of their functionality. However, minor differences between the modules do exist: Compared to its predecessor (nRF9161), nRF9151 has a 20 percent smaller footprint. It also supports a further power class 5 thanks to 20 dBm output power. In contrast, nRF9131 is better suited for high-volume cellular IoT applications that require individual certification, which can be somewhat costly for cus-

tomers. Alternatively, it is specifically designed for DECT NR+ applications, which are license-free and do not rely on cellular networks at all. Therefore, nRF9151 or nRF9161 is more likely to be used for a possible fallback scenario to cellular radio if an NR+ gateway is not within range. And by omitting the PMIC (power management IC), nRF9131 is much smaller than nRF9151. ■

Property	DECT NR+	LoRa	Mioty	SigFox	LTE-M	NB-IoT
Frequency	1.9 GHz	868 MHz (EU) 915 MHz (US)	868 MHz (EU) 915 MHz (US)	868 MHz (EU) 915 MHz (US)	700–2,200 MHz	700–2,200 MHz
Range	3–10 km	Up to 15 km	Up to 15 km	Up to 10 km	Up to 11 km	Up to 15 km
Data rate	High (3 Mbit/s – 9 Gbit/s)*	Slow (50 kbit/s)	Very slow (500 bit/s)	Very slow (600 bit/s)	Medium (1 Mbit/s)	Slow (250 kbit/s)
Latency	Very low (< 1 ms)	High (approx. 1 s)	High (approx. 1 s)	High (approx. 2 s)	Low (10–30 ms)	High (1.5–10 s)
Energy consumption	Very energy efficient	Very energy efficient	Very energy efficient	Very energy efficient	Very energy efficient	Very energy efficient
Scalability	Extremely high (up to one million nodes per km²)	High	High	Low	Medium	Medium
Topology	Point to Point, Star, Mesh	Star	Star	Star	Star	Star
Areas of application	Industrial IoT Smart City Smart Metering Professional Audio	Smart City Smart Farming Smart Environment	Smart Metering Building Management Industrial IoT Smart City	Applications for very small data volumes only: Smart Cities Smart Building	Wearables Smart Cities Health Care	Smart Metering Environment Monitoring Building Management

Overview of the differences and possible uses of the six technologies in various areas of application.  
\*) For low-power operation 3 Mbit/s; but technically up to 9 Gbit/s possible





RAB4 saves time in Real-Time Kinematics testing

# Tracking solutions for safety and security

*Codium Electronique combines engineering expertise with cutting-edge technology. Their mission? To revolutionize construction site safety by integrating advanced tracking and sensing technologies. With their patented software and the Rutronik System Solutions Adapter Board RAB4, Codium is at the forefront of Real-Time Kinematics (RTK) innovation.*

BY STEPHAN MENZE,  
HEAD OF GLOBAL INNOVATION  
MANAGEMENT AT RUTRONIK

**C**odium Electronique is an electronics company based in Langres in Haute-Marne, France, with a design office and a production unit. The engineers and technicians are working complementary in design projects for business partners. These design projects aim to imagine, develop, and industrialize the customer's technologies and applications of tomorrow in fields such as Industry, Agriculture, and Healthcare.

Codium is developing an accurate tracking solution for construction sites all around the world. Their aim is to improve the safety of constructions sites by easily integrating the latest tracking and sensing technologies into this dangerous environment. They use a patented software solution that automatically corrects and recalibrates all sensors. In the meantime, they are using RTK to ensure the safety of the workers on the construction site



Image: Suwin66/shutterstock.com



and to get data feedback to offer improvements to the workflows. Here, the Rutronik System Solutions Adapter Board RAB4 for RTK enabled Codium to test Unicore's RTK solution.

*Key components and advantages of the RAB4*

Accurate positioning plays a key role in many applications and is becoming increasingly important, for example, in concerning self-driving vehicles and environments with robots and increased human-machine interaction. Real-Time Kinematics is a technology that is

## Overview of Adapter Boards

### Rutronik Adapter Board – Text To Speech

- Voice control for HMI applications
- Output of up to twelve languages
- Target applications: e.g. vending machines, access control, or healthcare products

### Rutronik Adapter Board – HMS Anybus

- Secure entry into IIoT applications
- Features all important fieldbuses and interfaces in the industrial environment such as EtherCAT, Profinet, Modbus, Powerlink, CC-Link, and Profibus
- Offers the quickest entry for industrial ethernet/fieldbus, and can be configured through software

### Rutronik Adapter Board – RAB1 – sensor fusion

- State-of-the-art sensor fusion
- Combination of extremely powerful sensors from Infineon, Bosch SE, and Sensirion
- Intelligent combination of sensor values enables sensor fusion applications such as air quality measurement or for smoke and gas detectors

### Rutronik Adapter Board – RAB2 – CO<sub>2</sub>

- Testing CO<sub>2</sub> sensors for a wide range of applications

### Rutronik Development Kits - RDK

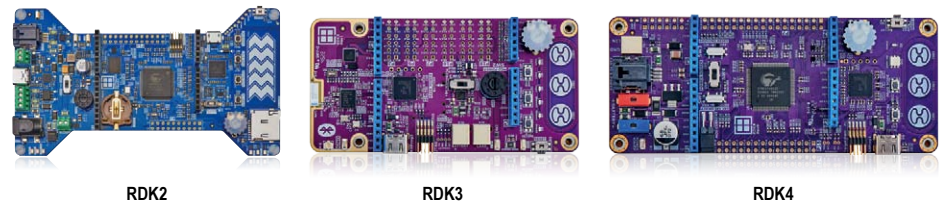
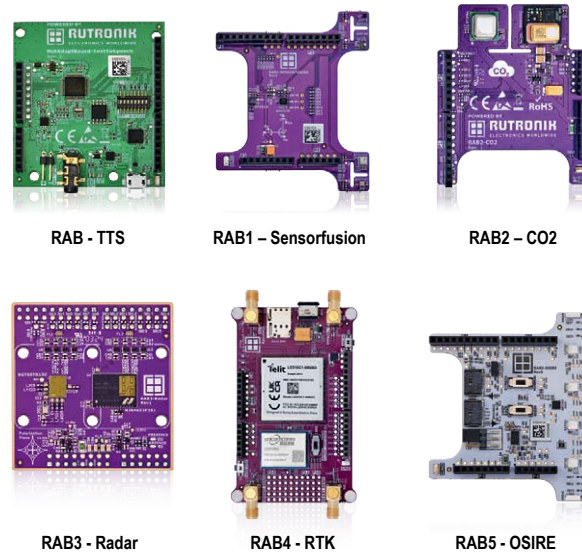

Image: Rutronik

### Rutronik Adapter Boards - RAB



### Rutronik Cooperation Boards



Overview of the Base Boards and Adapter Boards from Rutronik System Solutions

- Combination of extremely powerful sensors from Infineon and Sensirion
- Optimization of the sensor function for measuring CO<sub>2</sub>, relative humidity, and temperature

### Rutronik Adapter Board – RAB3 for radar

- Distance measurement, presence or obstacle detection
- Nisshinbo 60-GHz Smart Sensor Micro-Module for radar sensing at 60 GHz
- Infineon Xensiv 60-GHz Radar Sensor, a discrete radar IC, providing latest radar technology

### Rutronik Adapter Board – RAB4 for RTK

- Fast access to RTK for autonomous and automated outdoor applications
- State-of-the-art GNSS modules from Unicore Communications and Telit Cinterion, as well as various antennas from 2J

- High-precision positioning down to approx. 2 centimeters

### Rutronik Adapter Board – RAB5 – OSIRE

- Highly accurate optical calibration data for all LEDs included
- Dynamic color control and animations, no flickering up to 1 kHz PWM
- AEC-Q qualified for automotive applications

### Rutronik ABU Reference Board – Automotive Bidirectional 800-V Smart HV-Switch

- Safe switching of electronic loads in a high-voltage circuit
- eFuse combines the functions of a conventional fuse and a switch
- Low conduction losses and low power dissipation due to state-of-the-art silicon carbide MOSFETs



Front view of the Adapter Board RAB4



Back view of the Adapter Board

much more accurate than conventional multi-GNSS systems and is becoming more and more economically attractive. The RAB4 is an adapter board that can be used to quickly test the performance of the RTK technology in areas such as agriculture, precision farming, autonomous vehicles, drones, and lawn mowing robots.

Technical details of the RAB4 at a glance:

- The UM980 from Unicore is a high-precision RTK positioning module based on the latest generation of the GNSS SoC NebulasIV for a high positioning rate of 50 Hz and supports all available GNSS frequencies.
- To evaluate absolute positioning, the RAB4 features a 4G LTE module with an integrated standard multi-GNSS receiver from Telit Cinterion's LE910 series.
- The RAB4 also includes a prepaid SIM card preloaded with 100 MB of data. Thanks to this combination, NTRIP correction data

Advertisement

## Green Line



- > High-quality, recyclable products
- > CO<sub>2</sub>-neutral raw material over the entire life cycle
- > Reduction of up to 68% CO<sub>2</sub> compared to conventional plastics

[schurter.com](http://schurter.com)

Components with raw materials made from plant-based plastics



can be downloaded from the Internet (might require fees depending on the chosen provider).

*Centimeter precision  
in real-time*

With the RAB4, the experts from Rutronik System Solutions, in cooperation with the Rutronik Wireless Competence Center, have developed an adapter board that allows fast testing of RTK performance and comparison with a leading multi-GNSS receiver without having to design separate hardware.

RTK is a technology that increases the accuracy of satellite positioning systems using a base station that sends correction data to a moving receiver. Correction data can come from a local base station, for example via Wi-Fi, Bluetooth, or NR+, or can be received over an internet connection from a third-party correction service using Networked Transport of RTCM via Internet Protocol (NTRIP). An example is the SAPOS network which is free in 14 of the 16 Federal States in Germany. Private correction data providers enable transnational coverage and even better technical performance. Compared to conventional GNSS receivers, which often only determine one position per second, with Unicore UM980 up to 50 fix/s are possible. As a result, the technology achieves an accuracy of one to two centimeters, even on fast-moving vehicles.

*RTK as a future technology for positioning  
with design-in expertise from Rutronik*

The RAB4 helped Codium research and evaluate RTK for their surveillance and worker safety solutions.

Axel Moinet, Electronic Engineer and Doctor of Computer Science at Codium Electronique, says: "We are very thankful for the in-depth support from Rutronik's Field Application Engineers. Their advice was crucial for us in conceptualizing the firmware side and impressed us on how developed the RTK solution already was."

The Rutronik wireless experts have been working with Unicore Communications, one of the leading suppliers of RTK components, for several years. As a result, Rutronik benefits from deep insights into the development of positioning technologies. In addition, the potential of the RTK technology in the agricultural sector has long been known: There are already robotic mowers that use this technology. However, at around five times the price of a conventional device, they are extremely expensive.

Jordan Rose, Field Application Engineer at Rutronik, explains: "Now that the price of the necessary components is becoming much more economically attractive, we expect to see a significant change in this market in favor of RTK over the next three years."

To show the performance of RTK technology and the RAB4, the experts at Rutronik System Solutions with Jordan Rose as the project lead and software engineer have developed their own rover. The rover is easy to operate via an app and can be controlled with centimeter precision. Using an Arduino interface, the RAB4 is combined with the Base Board RDK3 from Rutronik System Solutions. The RDK3 allows a wireless connection via Bluetooth Low Energy. The reference station sends the correction data to the rover in a real-time protocol via Bluetooth. As a result, the rover can navigate in the garden with centimeter precision. Therefore, it is not necessary to lay a wire in the ground as a boundary. ■



Scan the QR code to watch the [rover demo](#).

Advertisement

Apacer

Enterprise Series SSD

Targeting edge servers, cloud servers, and mid-size data centers

- ✓ Support advanced CorePower (power loss protection) technology to ensure data integrity under abnormal power supply conditions.
- ✓ Support AES 256-bit hardware encryption and Signed Firmware technology to provide the security of data storage.
- ✓ Support SATA and PCIe Interface in **2.5", U.3, 2280, 22110, and E1.S form factors from 240 GB to 30 TB.**

Apacer Technology [www.apacer.com](http://www.apacer.com) [sales@apacer.nl](mailto:sales@apacer.nl)

electronica 2024  
Visit us at **Hall B4 Stand 419**

- File Server
- Proxy Server
- DNS Server
- Application Server
- Database Server
- Mail Server
- FTP Server
- Web Server

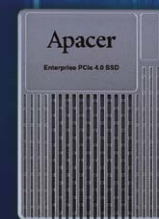



Reference design for on-board chargers

# Focus on miniaturization

*The circuit design of a compact charger with a three-phase mains connection, featuring high power density and efficiency, aids developers in implementing new designs.*

BY EDGAR SCHÄFER, FIELD APPLICATION ENGINEER IN THE AUTOMOTIVE BUSINESS UNIT (ABU) AT RUTRONIK

A three-phase mains connection for onboard chargers provides notable benefits, such as faster charging, improved efficiency, and reduced current load per phase. However, it also brings with it additional technical and infrastructural challenges, including complexity, costs, heat management, grid compatibility, and regulatory requirements. The development of such systems requires careful planning and design choices to achieve the aforesaid advantages while managing to overcome the

challenges – especially now that onboard chargers (OBC) are becoming increasingly important.

For this reason, the Automotive Business Unit (ABU) at Rutronik, together with its partners Vishay and Bosch Automotive Electronics (Bosch AE), has developed a reference design for an onboard charger with a three-phase mains connection for 400 V and a connected load of 11 kW as part of the "Reference designs for automotive applications" initiative.



## About the Rutronik Automotive Business Unit

The Automotive Business Unit (ABU) is tailored specifically to the automotive industry, partnering up with specially selected top-tier suppliers from the automotive sector. The ABU team sees itself as a consultant and intermediary, focused on understanding customer challenges and offering tailored information and expert recommendations.

The Automotive Business Unit is celebrating its tenth anniversary this year, and was holding its first ever Rutronik Automotive Convention in the USA in October 2024.



### High-Current Contact Elements

versatile possibilities for power applications and compact control units

mating with tab contacts – mateable from top, lateral or bottom direction

SMT and THT – also suitable for laser welding

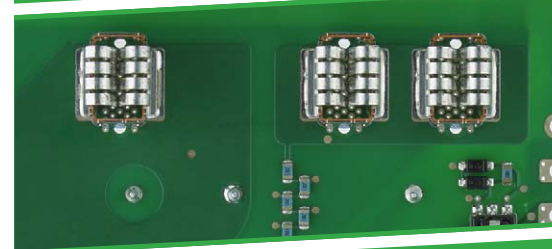

up to 75 A



Image: Vishay

**DIMENSIONS** in millimeters

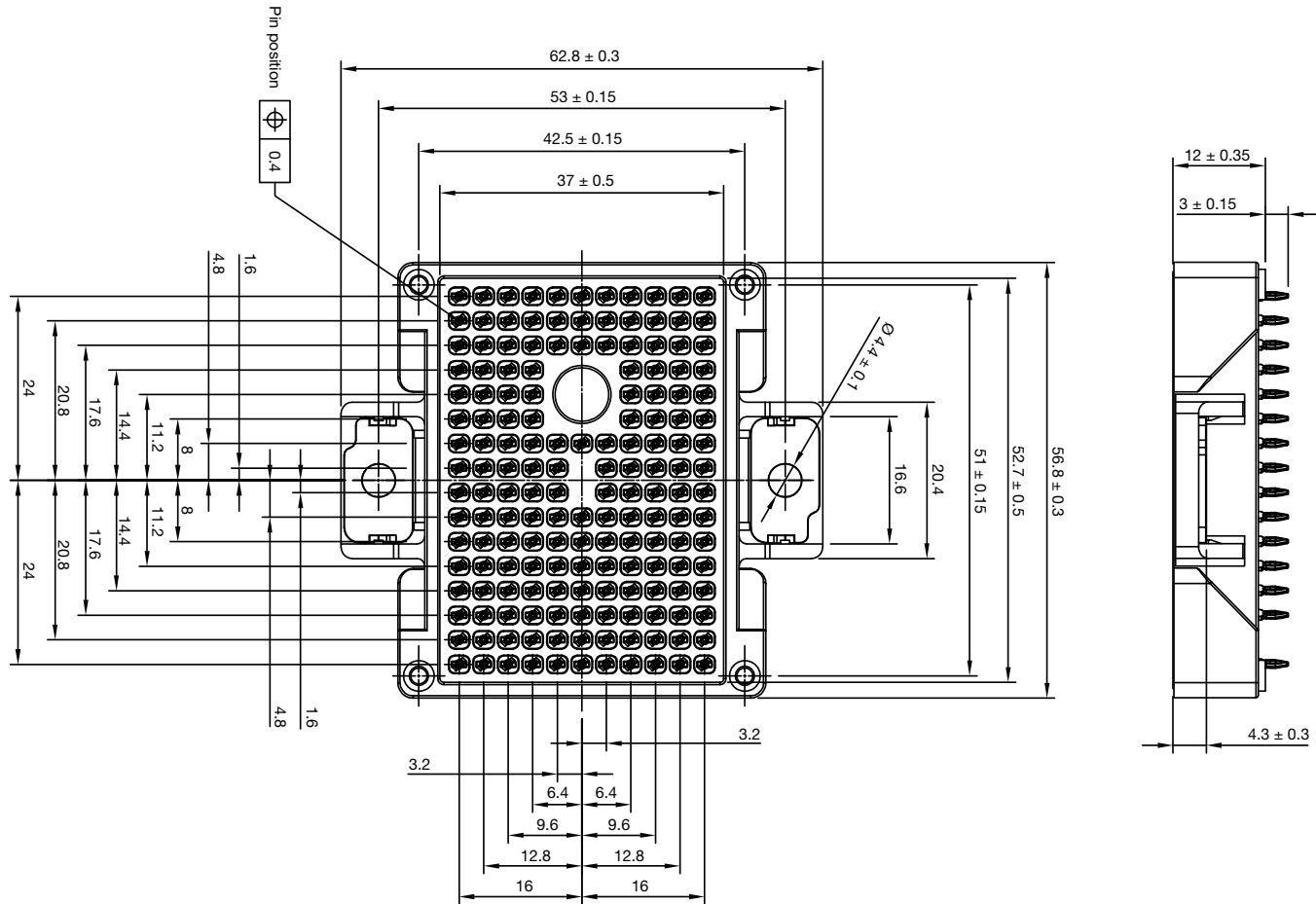

Advantages of the silicon carbide power MOSFETs in an EMIPAK 2B package: Equipped with PressFit pins for easy installation, the exposed substrate enhances thermal performance, while the optimized layout helps to reduce stray parameters for better EMI performance.

Particular focus is placed on miniaturization during the near-series development phase. In terms of its circuitry, the OBC consists of a Vienna rectifier with power factor correction, rectification, and a downstream DC/DC converter. The concept is brought to life with state-of-the-art high-performance components and the latest silicon carbide (SiC) technology. Discrete high-performance components and the package technology for the power modules are provided by Vishay. The non-packaged, silicon carbide MOSFETs (metal oxide semiconductor field-effect transistors) come from Bosch AE. The result is a compact charger with high-power density and efficiency. The rectifier with power factor correction is suitable for a wide input voltage range. Its application also facilitates compliance with circuit feedback requirements like EMC and reactive kVAh.

The DC/DC converter is designed as a galvanically isolated resonant converter with 500 V

secondary voltage and switching frequencies of between 150 kHz and 250 kHz. The key components are the pulse transformers and the resonant capacitors. The losses of both components have a significant impact on the overall efficiency of the converter.

*New components enable miniaturization*

The design uses the new 750 V series SiC MOSFETs from Bosch AE. Vishay integrates the silicon carbide dies into its EMIPAK 2B power modules (see Fig.). The SiC-MOSFETs have low on-resistances and enable high switching frequencies. At the same time, they exhibit low switching losses. The high operating frequency allows for the use of smaller inductances and capacitances. This enables smaller chokes, smaller pulse transformers, and smaller capacitors, which are essential for the mains filter or resonant cir-

cuit. MOSFETs therefore contribute significantly to reducing the required overall dimensions.

The power modules in the EMIPAK 2B package further support miniaturization. They offer high power density and are robust and field-proven. Their press-fit contacts ensure a secure and durable connection to the printed circuit board. Moreover, they can be easily and cost-effectively incorporated into the manufacturing process of the end product.

Integration of the power semiconductors into a package ensures low space requirements with excellent heat dissipation. The EMIPAK 2B base plate can be effortlessly connected to a water-cooled heat sink in the vehicle, for instance.

After DC/DC conversion, an asynchronous rectifier consisting of SiC diodes rectifies the voltage. Infineon is another partner and pro-

vides the microcontroller and the gate drivers.

*New developments in a short period of time*

The Automotive Business Unit at Rutronik along with its partners is excited about a circuit design that sparks new ideas and facilitates the transfer of knowledge. The development process of the customer is promoted and accelerated by Rutronik's comprehensive documentation and support. This includes free circuit diagrams and bill of materials (BOM). Moreover, the customer can customize the design to meet their needs. This allows developers to create bespoke products for various applications. ■

SF|robust  
Technology



- For Electric and Hybrid Electric Vehicle Applications:
- Brushless DC (BLDC) and permanent-magnet synchronous motor (PMSM) commutation in a safety-relevant environment
  - Electric brake booster
  - Electromechanical brake (EMB)
  - Clutch and transmission actuators
  - Starter/generator systems
  - Electric pumps
  - Electric valves

 TDK

## HAL 302x

### Fast 2D Hall-Effect Position Sensor Family

The HAL 302x hall-effect position sensor family was designed to excel in demanding automotive and industrial environments. Engineered with precision and reliability at the forefront, these sensors offer a dependable solution for precise motor position sensing. HAL 3020 and HAL 3021 feature:

- ◆ High-speed 360° angle measurement
- ◆ Robustness against magnetic stray-fields
- ◆ ASIL C ready for ISO 26262 compliance
- ◆ EMC robust analog output signals
- ◆ On-chip calibration and safety monitoring
- ◆ Wide magnetic-field range

Want to know more on our position sensor solutions for Automotive and Industrial applications?

Explore [www.micronas.tdk.com](http://www.micronas.tdk.com) for more details.





Reference design for micromobility with 48 V traction inverter

# For the mobility of tomorrow

*Traction inverters are crucial for the performance and efficiency of modern electric and hybrid drivetrains. Especially for the increasingly popular micromobility market, they must meet special requirements in terms of their size, weight, efficiency, and costs.*

BY RAHUL NAIK, FIELD APPLICATION ENGINEER IN THE AUTOMOTIVE BUSINESS UNIT (ABU) AT RUTRONIK

**M**icromobility refers to lightweight, often electrically powered, transportation designed for short distances in urban environments. Prime examples include e-scooters, e-bikes and e-skateboards. Due to their efficiency, comfort, and environmental friendliness, these mobility solutions have become very popular – especially for distances that are too far to walk comfortably but too short for conventional vehicles.

The traction inverter is a key component in the drive system of electric vehicles. It converts direct current (DC) from the vehicle battery into alternating current (AC), which powers the electric motor to drive the wheels. The traction inverter also manages the flow of current from the battery to the motor, controlling speed, torque, and regenerative braking. It plays a crucial role in determining the overall performance, efficiency, and responsiveness of the vehicle.

*Lightweight, compact, and cost-efficient*

Micromobility places special demands on traction inverters – they have to be compact, lightweight, and capable of efficiently man-

aging the power needs of the small electric motors. Technological advancements have propelled the development of traction inverters, resulting in smaller, lighter, and more efficient designs. Traditionally, bipolar traction inverters with an insulated control electrode (IGBTs) based on Si technology were used for power conversion. The use of semiconductors with a wide-bandgap offers improvements in terms of efficiency and thermal behavior: Modern materials such as silicon carbide (SiC) and gallium nitride (GaN) enable higher switching frequencies, lower power losses, and greater power density. Additionally, effective cooling methods are necessary to maintain optimal performance and reliability under demanding operating conditions. The challenge of dissipating the heat generated during operation has been solved by advances in thermal management.

*Reference designing as a team*

Together with its partner Vishay, the Automotive Business Unit at Rutronik has developed a traction inverter that meets the requirements of 48 V micromobility (Fig. 1). A decisive step was selecting the right components.

Images: Vishay



Figure 1: Prototype of the traction inverter

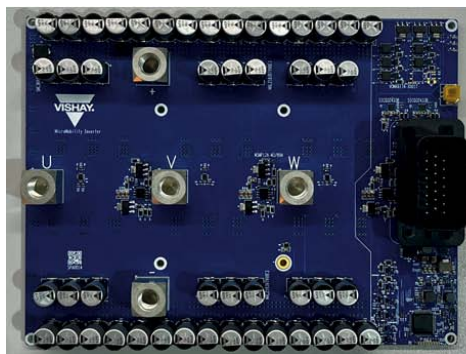
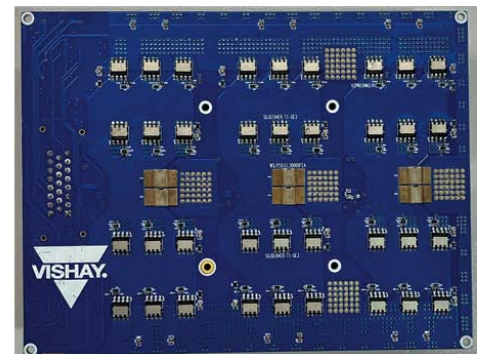

Figure 2: Printed circuit board of the traction inverter. Upper side with the DC link capacitors MAL218397998E3 (left). The surface-cooled MOSFETs are located on the underside of the PCB. The Power Metal Strip resistors WSLP5931 (right) are located in the center.





Type / Series	Description	Properties	Advantages
SQJQ184ER	TrenchFET Automotive N-Channel MOSFET	80 V, low $R_{DS(on)}$ , low $R_{th(j-c)}$ , top-side cooling, AEC-Q101	Automotive quality, low power loss, direct heat dissipation from the top, no heat dissipation through the PCB required, simple printed circuit board material, fewer vias
WSP5931, Power Metal Strip	Shunt resistor	AEC-Q200, low TCR (temperature coefficient of resistance), low thermoelectric voltage	Automotive quality, direct measuring principle with linear transfer function, insensitive to stray magnetic fields, no saturation effects during/after overcurrent
SiPQ32433B	eFuse IC with adjustable and precise overcurrent limitation	AEC-Q100, short response time, adjustable switch-on edge	Automotive quality, resettable fuse, fast triggering characteristic protects voltage source and electronic loads
183CPHT	Hybrid polymer aluminum capacitor	AEC-Q, 125°C, vibration resistance up to 30G, low ESR	Automotive quality, suitable for harsh environments, low self-heating, SMD can be populated
VOMA617A	Optocoupler with phototransistor output	AEC-Q101, high current carrying capacity, small flat package, 3,750 V RMA isolation voltage	Automotive quality, direct control by microcontroller possible, low space requirement on the printed circuit board

Properties and advantages of the components used for the reference design

In addition to current market requirements, the term "micro" also implies size requirements. Besides installation space, factors such as compatibility, heat dissipation, mechanical load, and component life cycle were also considered when selecting the components.

The result is a model implementation of a universal traction inverter designed for 48 V electrical systems for drivetrains in light-

weight L7e electric vehicles (four-wheeled vehicles with a maximum power output of 15 kW and a maximum speed of more than 45 km/h) and lower.

The reference design is based on cutting-edge, high-performance components such as power MOSFETs, TVS diodes, switching diodes and rectifiers, capacitors, resistors, NTC and PTC thermistors, as well as input filters (inductors and EMI filters). The 48 V traction

inverter has a continuous power output of 10 kW and a peak power output of 15 kW. The single PCB design reduces the complexity of the overall system.

The reference design demonstrates the circuit structure (Fig. 2) and the suitability of the selected components for the application (Table). As such, it serves as a customer guide for selecting components when developing a similar charger.

Advertisement



## Conductive Polymer Hybrid Aluminum Electrolytic Capacitor

### Features

- Excellent ripple characteristics
- Very low ESR
- Excellent low temperature characteristics (-55°C)
- Resolving the risk of short (dielectric self-restore function)

### Applications

- Automotive
  - Engine Control Unit
  - HVAC
  - Electric pump controller
  - DC-DC converter
- Communication equipment
  - 5G repeaters
- Household appliances
  - Vacuum cleaner (BLDC motor)
  - TV SMPS
- Medical devices



Please scan this QR Code for more information.

[www.samwha.co.kr/electric\\_eng](http://www.samwha.co.kr/electric_eng) | [europe@samwha.com](mailto:europe@samwha.com)





Figure 3:  
Design of the traction inverter

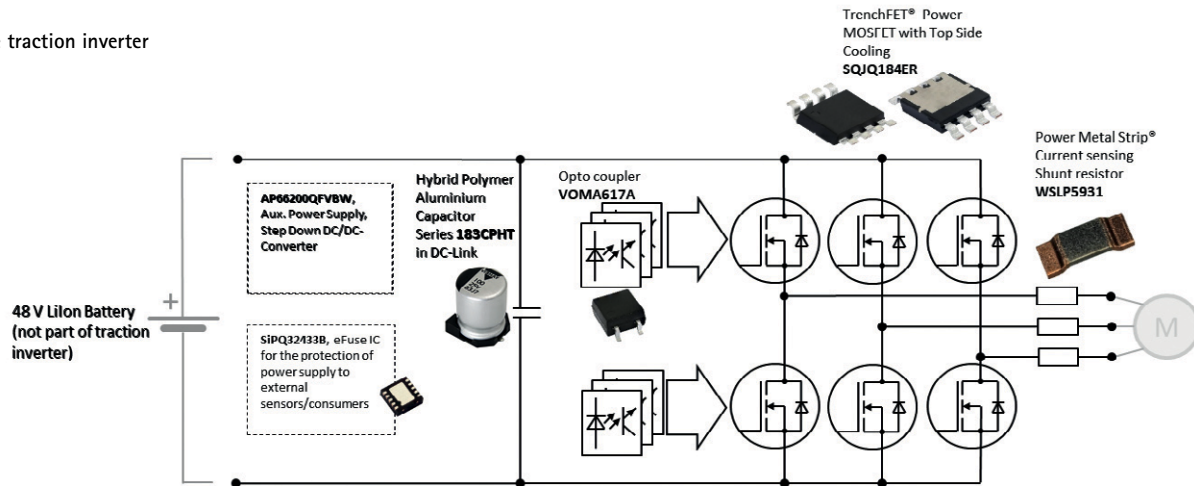

*Traction inverter offers new opportunities*

The effects of traction inverter technology extend well beyond individual vehicles, shaping the entire landscape of electric mobility. As electric vehicles become more prevalent, economies of scale and technological advancements will lower the costs of traction inverters and make electric drives more ac-

cessible to consumers. At the same time, there is increasing demand for specialized traction inverters tailored to the unique needs of micromobility vehicles, including size, weight, efficiency, and costs, while delivering the performance and reliability necessary for urban traffic.

Moreover, the electrification of transport opens up new opportunities for grid integra-

tion and demand management. Bidirectional charging functions enabled by traction inverters allow electric vehicles to act as mobile energy storage devices, feeding energy back into the grid during peak load periods or providing backup power in emergencies. ■

**Publishing details**

Editorial staff:  
Andreas Mangler – Rutronik, Director Strategic Marketing and authorized representative (Editor-in-Chief, responsible for all content), phone +49 7231 801 0  
Markus Krieg – Rutronik, Chief Marketing Officer  
Dr. Anna-Lena Gutberlet – freelance specialised journalist  
Dr. Alena Kirchenbauer – Rutronik, Team Leader International Communication

Advertising Manager: Ipek Baskurt – Rutronik, Communication Designer  
Final editing: Achim Grolman, Markt&Technik  
Layout and Design: Wolfgang Bachmaier, Markt&Technik; Alexander Zach, Markt&Technik

Print: Vogel Druck und Medienservice GmbH, Leibnizstr 5, 97204 Höchberg

Publisher and general address: Rutronik Elektronische Bauelemente GmbH, Industriestr. 2, 75228 Ispringen, Germany, phone +49 7231 801 0, fax +49 7231 82282

Copyright: All articles published in Rutroniker, powered by Markt&Technik are copyrighted. We reserve all rights to all such texts, including translations. Any kind of duplication, whether photocopies, microfilm or recording in data processing systems is only permitted following written approval by the publisher and editor.

An operated solution or used description should not be constructed as free from industrial proprietary rights on the basis of this publication.

Liability: In the event that Rutroniker, powered by Markt&Technik contains inaccurate information or if published programmes or advertisements contain errors, the publisher, its employees or the editor shall only be liable in case of gross negligence.

Circulation: 21,000 (German) + 5,000 (English)

Special thanks:  
Alexander Marder – Rutronik, Junior International Content Marketing Manager  
Achim Grolman, Markt&Technik  
Christian Stadler, Markt&Technik

**List of advertisers**

Adam Tech .....	57
Apacer Technology B.V. ....	76
Eaton Electrical Products Ltd .....	56
FCL Components Europe B.V. ....	51
Gowin .....	41
INFINEON Technologies AG .....	84
INTEL Corporation (UK) LTD .....	42–43
JAE Europe Ltd. ....	37, 63
Kioxia Europe GmbH .....	83
Kitagawa .....	54
Kontron Europe GmbH .....	9, 45
Littelfuse Europe GmbH .....	69
Lumberg Connect GmbH .....	77
Molex Interconnect GmbH .....	3, 7, 11
MPE Garry .....	53
Nordic Semiconductor ASA .....	2
Omron Electronic Components Europe B.V. ....	71
Powertip .....	29
RECOM Power GmbH .....	65
ROHM Semiconductor GmbH .....	28
Samwha .....	81
Sauro .....	33
Schurter .....	75
Su'scon .....	49
TDK - Micronas GmbH .....	79
Transcend Information Trading GmbH .....	59
TRUH GmbH .....	23
Vishay Europe Sales GmbH .....	31
Yageo Corporation .....	67



# KIOXIA

## KIOXIA – Memory Maker

Making Industrial Data storage more Reliable



### SLC NAND – High Endurance

KIOXIA's SLC NAND flash memory provides best in class endurance and data retention for sensitive or frequently used data, especially for long lasting products or systems working with extremely high data throughput between the host and the memory.

**Applications:**

- Industrial Applications
- Consumer Electronics
- Multimedia Applications
- Smart Metering & Intelligent Lighting
- Smart Applications

Based on the „one bit per cell“-structure, SLC NAND can resist a significant higher number of write erase stress during lifetime than any MLC/TLC based product. This enables the system designer to develop a long lasting and extreme reliable storage solution even in challenging environments or use case scenarios.

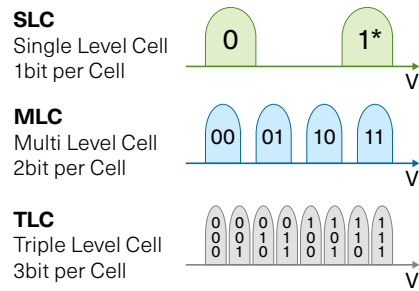

\* The binary assignment is individual set by each vendor

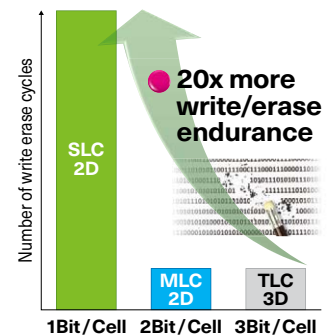

### e-MMC – High Efficiency

KIOXIA's e-MMC is a highly efficient NAND flash memory with an integrated controller for enhanced memory management. Based on an interface standardized by JEDEC, KIOXIA e-MMC offers the optimal solution for applications where higher data volumes need to be stored in an efficient way. Standard and extended temperature range of up to 105°C.

**Applications:**

- Industrial Applications
- Consumer Electronics
- Multimedia Applications
- Smart Metering & Intelligent Lighting
- Smart Applications

**4GB e-MMC available in 3 package sizes with same ball arrangement**

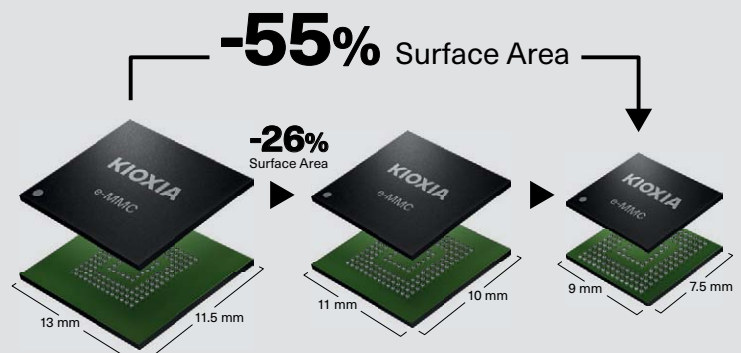



# Choose the correct High-Side Switch for your Industrial application

Smart Switches play a critical role in designing an industrial application, serving as fundamental components for controlling, monitoring, and safeguarding equipment and processes.

**Infineon Industrial PROFET™ smart high-side switches are according to JEDEC JESD47J and were designed for all types of resistive, inductive, and capacitive loads.**

- Supply voltage up to 60 V
- Adjustable current limitation with external resistor
- Discharge functionality for faster load discharge
- Digital Diagnostic via status pin
- Broad portfolio to cover wide output current range
- Single/dual/quad channel

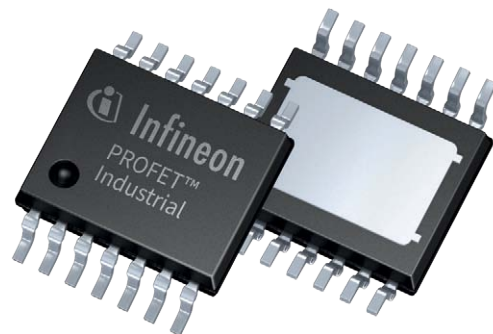

Feature set varies with product type.



Learn more  
[www.rutronik.com/Infineon/ee-architecture](http://www.rutronik.com/Infineon/ee-architecture)

