

# PAN1740A

Bluetooth<sup>®</sup> Low Energy Module  
Module Integration Guide

Rev. 1.1

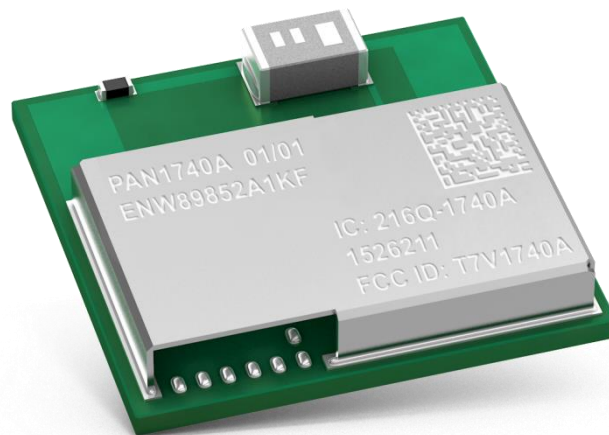

## Overview

The PAN1740A is an optimized version of the PAN1740, offering a reduced boot time and supporting up to eight connections. It has a fully integrated radio transceiver and baseband processor for Bluetooth® 5 Low Energy (LE). It can be used as a stand-alone application processor or as a data pump in hosted systems. The device is optimized for remote control units (RCU) requiring support for voice commands and motion/gesture recognition. Its integrated Audio Unit (AU) offers easy interface for MEMS microphones over PDM, external codecs over PCM/I<sup>2</sup>S, and a Sample Rate Converter unit. The Bluetooth LE firmware includes the L2CAP service layer protocols, Security Manager (SM), Attribute Protocol (ATT), the Generic Attribute Profile (GATT), and the Generic Access Profile (GAP). All profiles published by the Bluetooth SIG as well as custom profiles are supported. The transceiver interfaces directly to the antenna and is fully compliant with the Bluetooth 5 standard. The PAN1740A has dedicated hardware for the Link Layer implementation of Bluetooth LE and interface controllers for enhanced connectivity capabilities.

## Features

- Pre-programmed Bluetooth/MAC address
- Includes 16 MHz and 32 768 kHz crystal calibrated up to 1 ppm
- Single mode Bluetooth 5 System-on-Chip
- Programmable ARM® Cortex®-M0 CPU
- Autonomous Bluetooth LE stand-alone operation
- Bluetooth 5 (LE) embedded GATT profile (LE single mode)
- Dimensions: 9 mm x 9.5 mm x 1.8 mm (SMD package with antenna)
- Less than a few  $\mu$ A in low power modes
- Integrated shielding to resist EMI
- No external components needed

## Characteristics

- Peak power consumption: 4.9 mA (Rx and Tx)
- Link budget: 93 dB (Rx sensitivity: -93 dBm, Tx sensitivity 0 dBm)
- Operating temperature range -40 °C to 85 °C

## Block Diagram

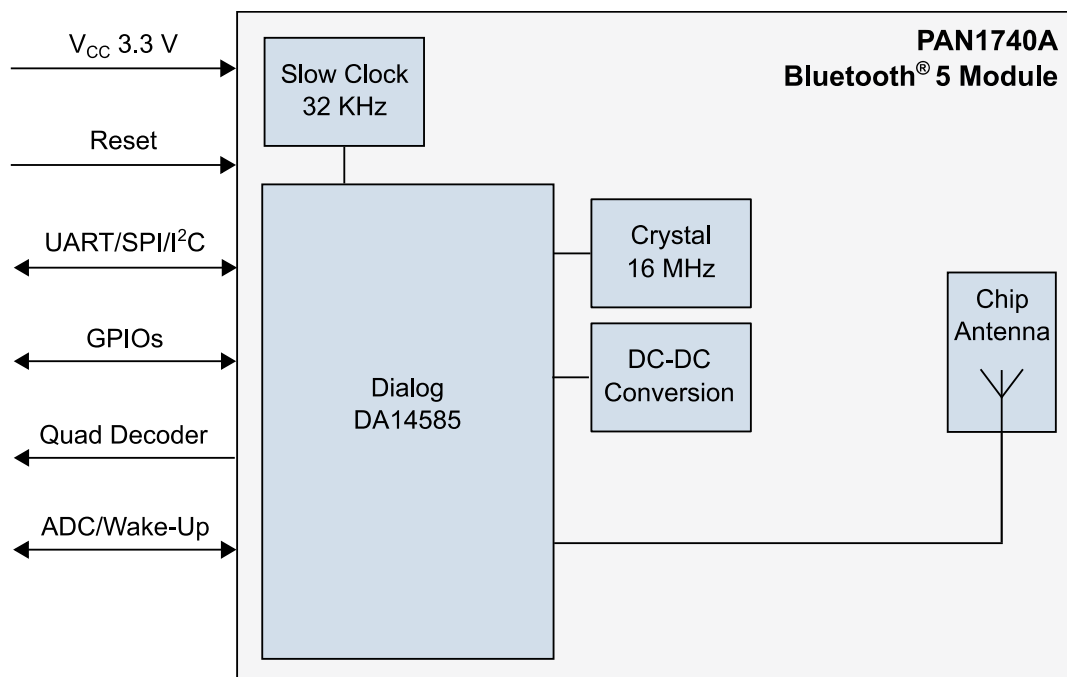

By purchase of any of the products described in this document the customer accepts the document's validity and declares their agreement and understanding of its contents and recommendations. Panasonic Industrial Devices Europe GmbH (Panasonic) reserves the right to make changes as required at any time without notification. Please consult the most recently issued Module Integration Guide before initiating or completing a design.

© Panasonic Industrial Devices Europe GmbH 2020.

This specification sheet is copyrighted. Reproduction of this document is permissible only if reproduction is without alteration and is accompanied by all associated warranties, conditions, limitations, and notices. Do not disclose it to a third party.

All rights reserved.

This Module Integration Guide does not lodge the claim to be complete and free of mistakes.

## Engineering Samples (ES)

If Engineering Samples are delivered to the customer, these samples have the status "Engineering Samples". This means that the design of this product is not yet concluded. Engineering Samples may be partially or fully functional, and they may differ from the published Product Specification.

Engineering Samples are not qualified and they are not to be used for reliability testing or series production.

### Disclaimer

The customer acknowledges that samples may deviate from the Module Integration Guide and may bear defects due to their status of development and the lack of qualification mentioned above.

Panasonic rejects any liability or product warranty for Engineering Samples. In particular, Panasonic disclaims liability for damages caused by:

- The use of the Engineering Sample other than for evaluation purposes, particularly the installation or integration in another product to be sold by the customer,
- Deviation or lapse in function of the Engineering Sample,
- Improper use of the Engineering Sample.

Panasonic Industrial Devices Europe GmbH disclaims any liability for consequential and incidental damages. In case of any queries regarding the Engineering Samples, please contact your local sales partner or the related product manager.

The information contained herein is presented only as guidance for Product use. No responsibility is assumed by Panasonic for any infringement of patents or any other intellectual property rights of third parties that may result from the use of Product. No license to any intellectual property right is granted by this document, whether express or implied, by estoppel or otherwise.

Description of hardware, software, and other information in this document is only intended to illustrate the functionality of the referred Panasonic product. It should not be construed as guaranteeing specific functionality of the product as described or suitable for a particular application.

Any provided (source) code shall not be used or incorporated into any products or systems whose manufacture, use or sale is prohibited under any applicable laws or regulations.

Any outlined or referenced (source) code within this document is provided on an "as is" basis without any right to technical support or updates and without warranty of any kind on a free of charge basis according to § 516 German Civil Law (BGB) including without limitation, any warranties or conditions of title, non infringement, merchantability, or fitness for a particular purpose. Customer acknowledges that (source) code may bear defects and errors.

The third-party tools mentioned in this document are offered by independent third-party providers who are solely responsible for these products. Panasonic has no responsibility whatsoever for the performance, product descriptions, specifications, referenced content, or any and all claims or representations of these third-party providers. Panasonic makes no warranty whatsoever, neither express nor implied, with respect to the goods, the referenced contents, or any and all claims or representations of the third-party providers. To the maximum extent allowable by Law Panasonic assumes no liability whatsoever including without limitation, indirect, consequential, special, or incidental damages or loss, including without limitation loss of profits, loss of opportunities, business interruption, and loss of data.

## Table of Contents

<b>1</b>	<b>About This Document .....</b>	<b>6</b>
1.1	Purpose and Audience.....	6
1.2	Revision History .....	6
1.3	Use of Symbols .....	6
1.4	Related Documents .....	7
<b>2</b>	<b>Overview.....</b>	<b>8</b>
<b>3</b>	<b>PAN1740A Module.....</b>	<b>9</b>
3.1	Block Diagram.....	9
3.2	Footprint.....	10
3.3	Placement .....	11
<b>4</b>	<b>Reference Design .....</b>	<b>13</b>
4.1	USB-Dongle.....	13
4.2	Mother Board .....	14
4.3	Adapter Board.....	15
<b>5</b>	<b>Getting Started .....</b>	<b>16</b>
5.1	Device Drivers.....	16
5.2	Software Examples.....	16
<b>6</b>	<b>Run the Keil Project (Example) .....</b>	<b>17</b>
<b>7</b>	<b>Proximity Profile with two PAN1740A USB-Dongles (Example).....</b>	<b>20</b>
<b>8</b>	<b>Smart Snippets.....</b>	<b>23</b>
8.1	Program Structure .....	23
8.2	Application Demo: Proximity Profile.....	27
<b>9</b>	<b>Dialog Serial Port Service (DSPS).....</b>	<b>29</b>
9.1	Pro Kit with PAN1740A Adapter Board (iPod) .....	29
9.2	Two Pro Kits with PAN1740A Adapter Board .....	32
9.3	Two PAN1740A USB Sticks.....	32
<b>10</b>	<b>Production Tools.....</b>	<b>34</b>
<b>11</b>	<b>Regulatory and Certification Information .....</b>	<b>35</b>
11.1	General Certification Information.....	35
11.2	Federal Communications Commission (FCC) for US.....	35
11.3	Innovation, Science, and Economic Development (ISED) for Canada.....	37
11.4	European Conformity According to RED (2014/53/EU).....	41
11.5	Bluetooth.....	42
<b>12</b>	<b>Restricted Use.....</b>	<b>43</b>
12.1	Life Support Policy.....	43
12.2	Restricted End Use.....	43
<b>13</b>	<b>Contact Details.....</b>	<b>44</b>
13.1	Contact Us .....	44
13.2	Product Information .....	44

# 1 About This Document

## 1.1 Purpose and Audience

This Module Integration Guide is intended to support the easy integration of the PAN1740A into a product and to ensure the compliance with regulatory requirements.

This guide gives an overview about the hardware design requirements by providing a reference design, which is the evaluation board of the PAN1740A. It describes how to use the PAN1740A on the evaluation board with the software packages and tools provided by Dialog® Semiconductors. In addition, it explains how to start up the evaluation board, get all the needed software sources, execute example code and build own implementations.



It is intended for hardware design, application, and Original Equipment Manufacturers (OEM) engineers.

The product is referred to as “the PAN1740A” or “the module” within this document.

## 1.2 Revision History

Revision	Date	Modifications/Remarks
1.0	2019-11-07	First version
1.1	2020-05-14	New design. Renamed “Design Guide” into „Module Integration Guide“ and updated structure. Renamed “PAN1740/1740A” into “PAN1740A”. Updated chapter “Bluetooth”: added end product ID. Updated chapter “Regulatory and Certification Information”. Updated picture “Antenna Placement Recommendation”.

## 1.3 Use of Symbols

Symbol	Description
	<b>Note</b> Indicates important information for the proper use of the product. Non-observance can lead to errors.
	<b>Attention</b> Indicates important notes that, if not observed, can put the product’s functionality at risk.
	<b>Tip</b> Indicates useful information designed to facilitate working with the module and software.
⇒ [chapter number] [chapter title]	<b>Cross reference</b> Indicates cross references within the document. <b>Example:</b> Description of the symbols used in this document ⇒ <a href="#">1.3 Use of Symbols</a> .

Symbol	Description
✓	<p><b>Requirement</b></p> <p>Indicates a requirement that must be met before the corresponding tasks can be completed.</p>
➔	<p><b>Result</b></p> <p>Indicates the result of a task or the result of a series of tasks.</p>
This font	<p><b>GUI text</b></p> <p>Indicates fixed terms and text of the graphical user interface.</p> <p><b>Example:</b></p> <p>Click <b>Save</b>.</p>
Menu > Menu item	<p><b>Path</b></p> <p>Indicates a path, e.g. to access a dialog.</p> <p><b>Example:</b></p> <p>In the menu, select <b>File &gt; Setup page</b>.</p>
This font	<p><b>File names, messages, user input</b></p> <p>Indicates file names or messages and information displayed on the screen or to be selected or entered by the user.</p> <p><b>Examples:</b></p> <p>pan1760.c contains the actual module initialization.</p> <p>The message Failed to save your data is displayed.</p> <p>Enter the value Product 123.</p>
<span style="border: 1px solid black; padding: 2px;">Key</span>	<p><b>Key</b></p> <p>Indicates a key on the keyboard, e.g. <span style="border: 1px solid black; padding: 2px;">F10</span>.</p>

## 1.4 Related Documents

For related documents please refer to the Panasonic website ⇒ [13.2 Product Information](#).

## 2 Overview

The PAN1740A is an optimized version of the PAN1740, offering a reduced boot time and supporting up to eight connections. It has a fully integrated radio transceiver and baseband processor for Bluetooth 5 LE. It can be used as a stand-alone application processor or as a data pump in hosted systems. The device is optimized for remote control units (RCU) requiring support for voice commands and motion/gesture recognition. Its integrated Audio Unit (AU) offers easy interface for MEMS microphones over PDM, external codecs over PCM/I<sup>2</sup>S, and a Sample Rate Converter unit. The Bluetooth LE firmware includes the L2CAP service layer protocols, Security Manager (SM), Attribute Protocol (ATT), the Generic Attribute Profile (GATT), and the Generic Access Profile (GAP). All profiles published by the Bluetooth SIG as well as custom profiles are supported. The transceiver interfaces directly to the antenna and is fully compliant with the Bluetooth 5 standard. The PAN1740A has dedicated hardware for the Link Layer implementation of Bluetooth LE and interface controllers for enhanced connectivity capabilities.

For related documents please refer to ⇒ [13.2 Product Information](#).



### 3 PAN1740A Module

#### 3.1 Block Diagram

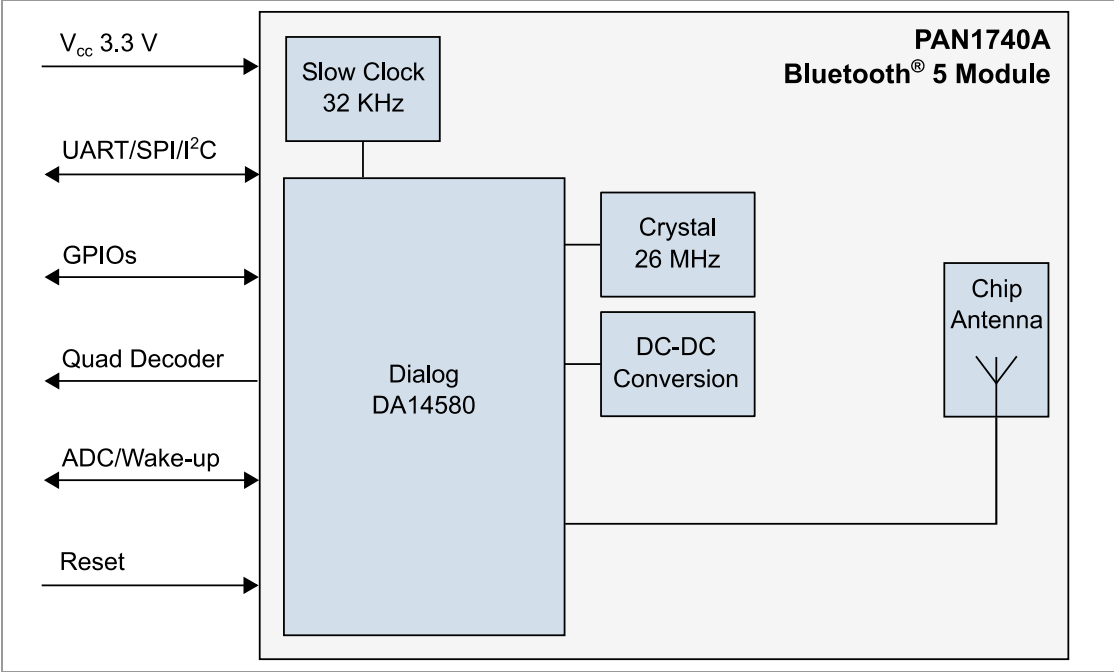

Total capacity shall not exceed 2.5  $\mu$ F.  
The total inductance shall not exceed 2.5  $\mu$ H.  
There is no resistor value in this design.

### 3.2 Footprint

 The dimensions are in millimeters.  
The outer dimensions have a tolerance of  $\pm 0.2$  mm.  
The inner pins (2, 4, 6, 9, 11, 14, 16, 18, 21, 23) are shifted to the center by 1 mm.

Top View

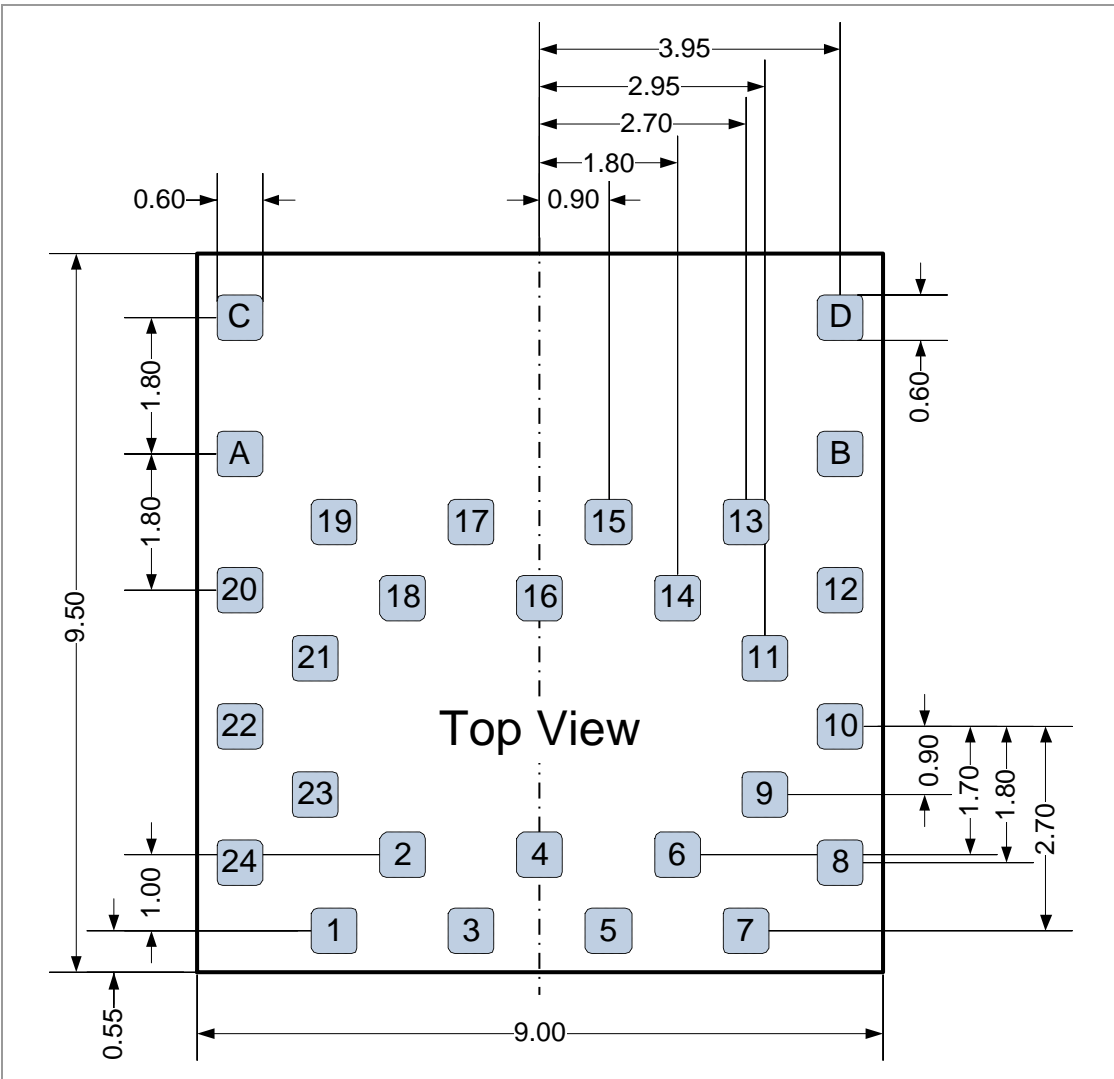

### 3.3 Placement



#### Antenna “Keep out Area”

Do not place any ground plane under the marked restricted antenna area in any layer! This would be affecting the performance of the chip antenna in a critical manner.



#### Impact of Placement on the Antenna Radiation Pattern

The placement of the module, surrounding material, and customer components has an impact on the radiation pattern of the antenna.



The recommendation for the ground plane is based on a FR4 4-Layer PCB.

The following requirements must be met:

- ✓ Keep this product away from heat. Heat is the major cause of decreasing the life of these products.
- ✓ Keep this product away from other high frequency circuits.

The antenna requires a cutout area of 5 mm x 3 mm under the PAN1740A module. This “Keep out Area” shall be located in every layer under the module antenna. Note for example the “Keep out Area” in all four layers of the PAN1740A evaluation board.

It is recommended to verify the perfect position of the module in the target application before fixing the design.

 All dimensions are in millimeters.

 Use a ground plane in the area surrounding the module wherever possible.

It is recommended to place the module:

- In the center (horizontal) of mother PCB.
- At the edge (horizontal) of mother PCB.

### Antenna Placement Recommendation

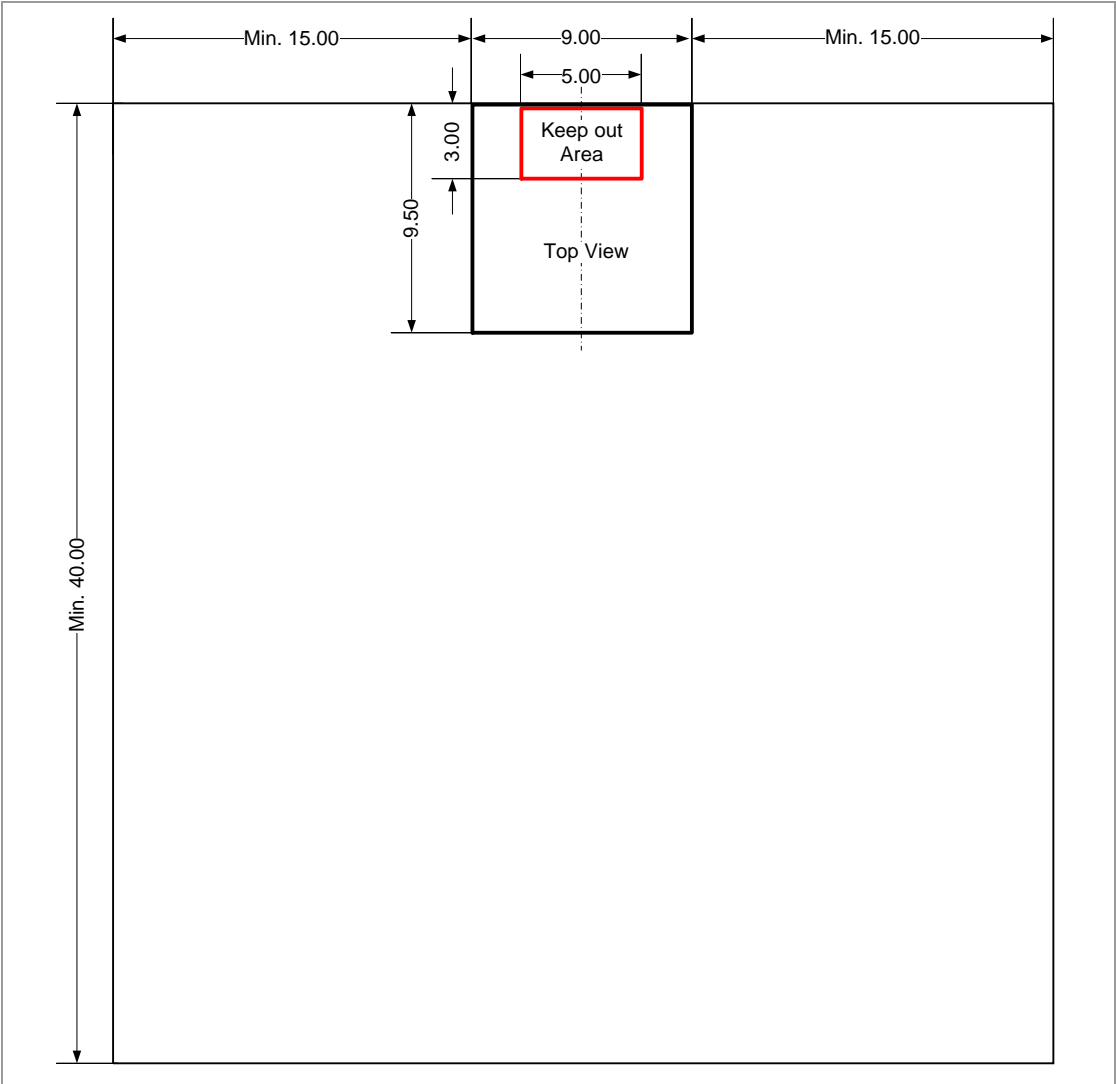

# 4 Reference Design

## 4.1 USB-Dongle

### 4.1.1 Functionality

- Atmel  $\mu$ C includes Segger USB-to-UART programmer (serial number on the backside)
- OTP cannot be damaged (fail-safe development)
- Runs with Dialog's Keil<sup>®</sup> Compiler projects
- Runs with Connection Manager
- Can be used for software development "on the fly"

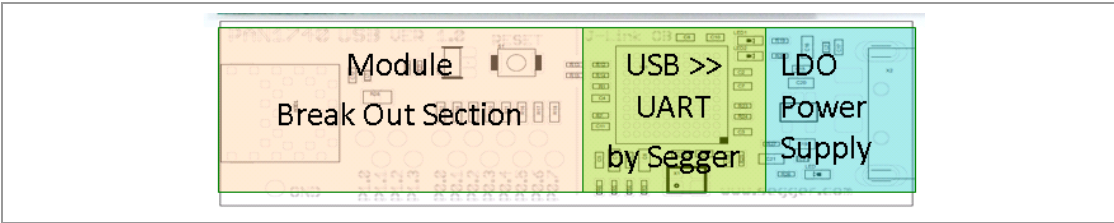
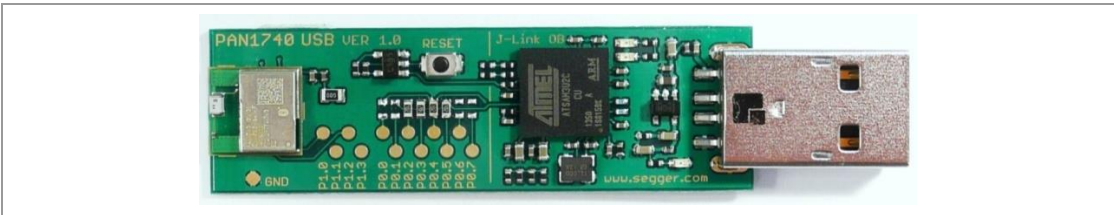

### 4.1.2 Schematic

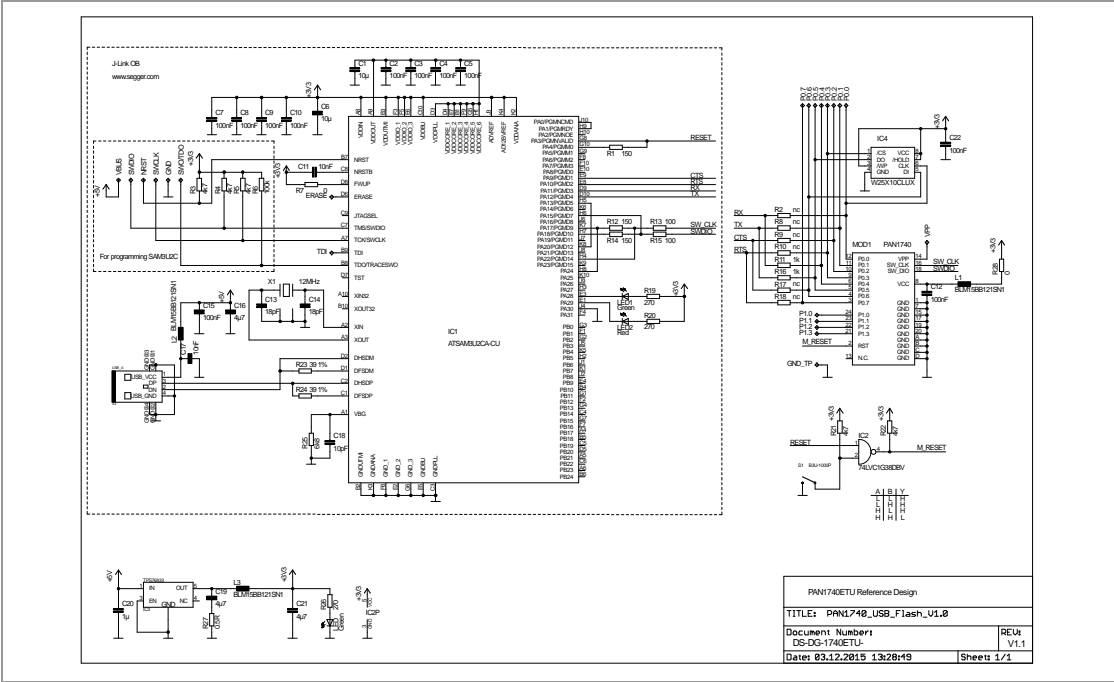

## 4.2 Mother Board

### 4.2.1 Functionality

- Can be used with PAN1740A Adapter Board
- OTP can be programmed
- Runs with Dialog's Keil Compiler projects
- Runs with Connection Manager
- Can be used for software development "on the fly"
- Runs with Smart Snippets™ including Power Profiler



### 4.2.2 Placement

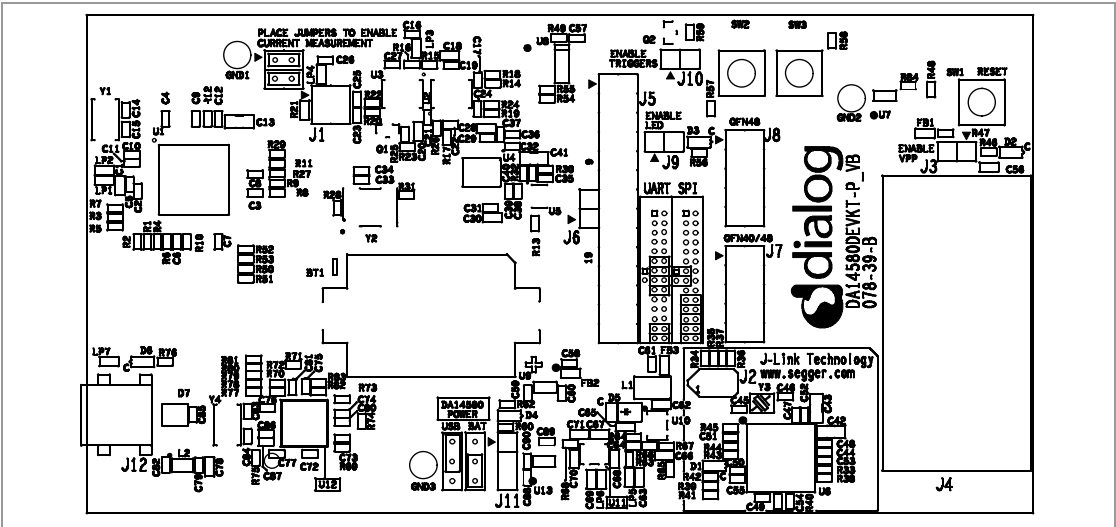

**4.3 Adapter Board**

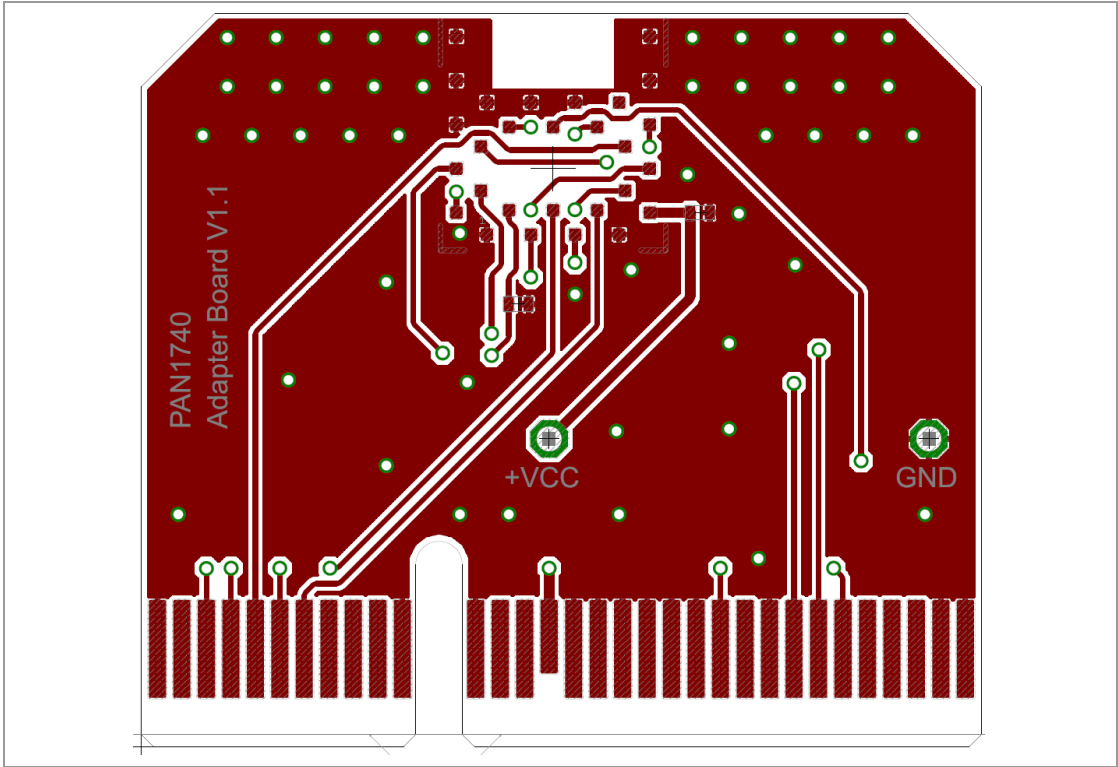

**Schematic**

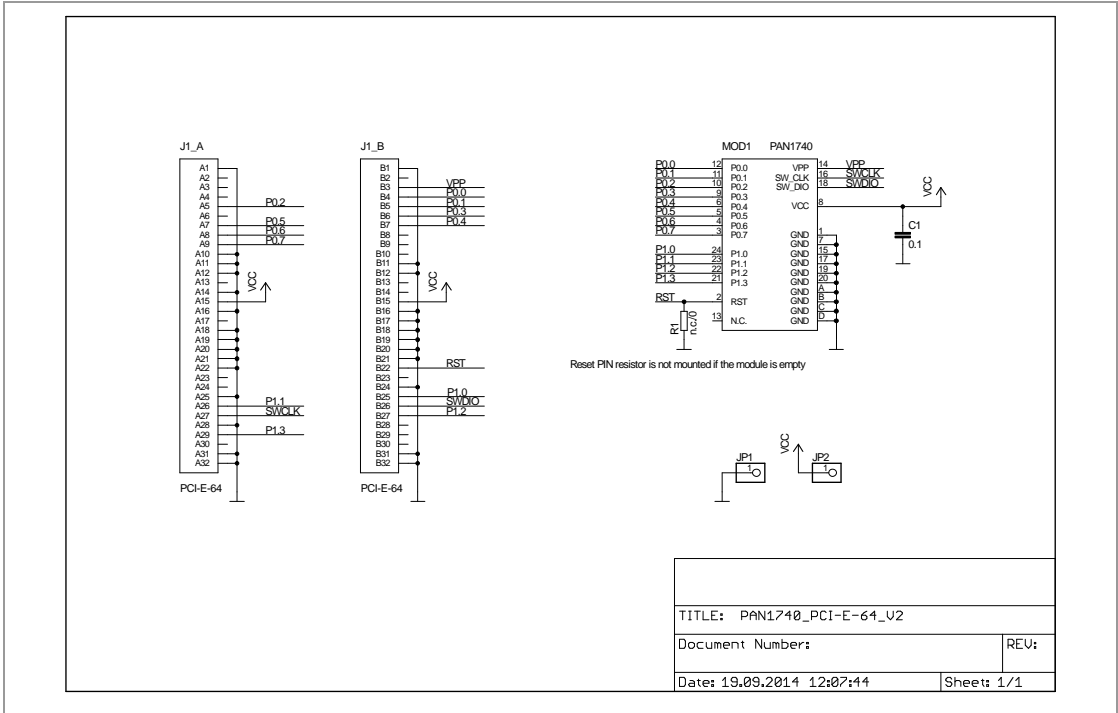

## 5 Getting Started

### 5.1 Device Drivers

#### 5.1.1 FTDI USB UART

Depending on the operating system that is used, drivers for the “FTDI USB UART” might not be installed automatically. If in doubt, please check the FTDI website and install the drivers manually.

For further information please visit <https://www.ftdichip.com/Drivers/VCP.htm>.

#### 5.1.2 Segger J-Link SWD Debugger

Depending on the operating system that is used, drivers for “Segger J-Link” SWD debugger might not be installed automatically. If in doubt, please check the “Segger” website and install the drivers manually.

For further information please visit <https://www.segger.com/downloads/jlink/>.

### 5.2 Software Examples

The PAN1740A USB evaluation board is delivered without any preinstalled software examples, but the following chapters describe how to use the recommended development environment and the Dialog Semiconductors Software Development Kit (SDK) to run different kinds of software examples.



## 6 Run the Keil Project (Example)

The following requirements must be met:

- ✓ SDK is installed.
- ✓ USB-Dongle is installed.



Use always the latest release from Dialog's website <https://www.dialogs.com/>.

1. Open the Dialog SDK.
2. Open the proximity project example. The project is located in the following SDK folder.

```

131 * Brief Main routine of the DA14580 Engineering Examples Functions
132 * DA14580 Peripherals Usage Examples
133 *
134 * - UART
135 * - SPI Flash
136 * - Boot From SPI flash
137 * - EEPROM
138 * - Timers
139 * - Battery Level Indication - ADC
140 * - Quadrature
141 *
142 * Due to HW Development Kit limitations, user must select one of the following configuration for UART, SPI, I2C.
143 * Additional Hardware (SPI, EEPROM boards) or Hardware modification may be needed for some of the tests.
144 * More information in the file periph_setup.h, Application Notes, and User Guide for DA14580
145 * - UART only (No HW modifications on rev C2 motherboard, No additional hardware)
146 * - SPI Flash with UART (HW modifications & additional Hardware needed, SPI_DI PIN on the additional SPI / EEPROM daughterboard )
147 * - Boot From SPI Flash without UART (Additional Hardware needed)
148 * - Boot From EEPROM with UART (Additional Hardware needed)
149 *
150 * .....
151 */
152 int main (void)
153 {
154     short int index = 0;
155     char mchoicex;
156
157     periph_init();
158     printf_string("DA14580 Engineering Examples\n\r");
159     printf_string("Connect the appropriate peripheral before choosing each test\n\r\n\r");
160     printf_string("Refer to Engineering Examples User Guide\n\r\n\r");
161
162     print_menu();
163
164     while(1){
165         if (index==1) break;
166         mchoicex = uart_receive_byte();
167         switch (mchoicex){
168             case 'u': uart_test(); endtest_bridge(index); break;
169             case 'f': spi_test(); endtest_bridge(index); break;
170             case 'i': spi_image(); endtest_bridge(index); break;
171             case 'e': i2c_test(); endtest_bridge(index); break;
172             case 'd': i2c_image(); endtest_bridge(index); break;
173             case 'c': swt_test(); endtest_bridge(index); break;
174             #ifdef QUADEC_ENABLED
175                 case 'q': quad_decoder_test(); endtest_bridge(index); break;
176             #endif //QUADEC_ENABLED
177             case 't': timers_test(); endtest_bridge(index); break;
178         }
179         index++;
180     }
181 }
    
```

Build Output

```

Build target 'Cortex-M0 SDR - Simulator'
linking...
Program Size: Code=11516 RO-data=18584 RW-data=32 ZI-data=1908
FromELF: creating hex file...
"..Out\periph_setup.axf" - 0 Errors, 0 Warning(s).
    
```

3. Open Keil Compiler.

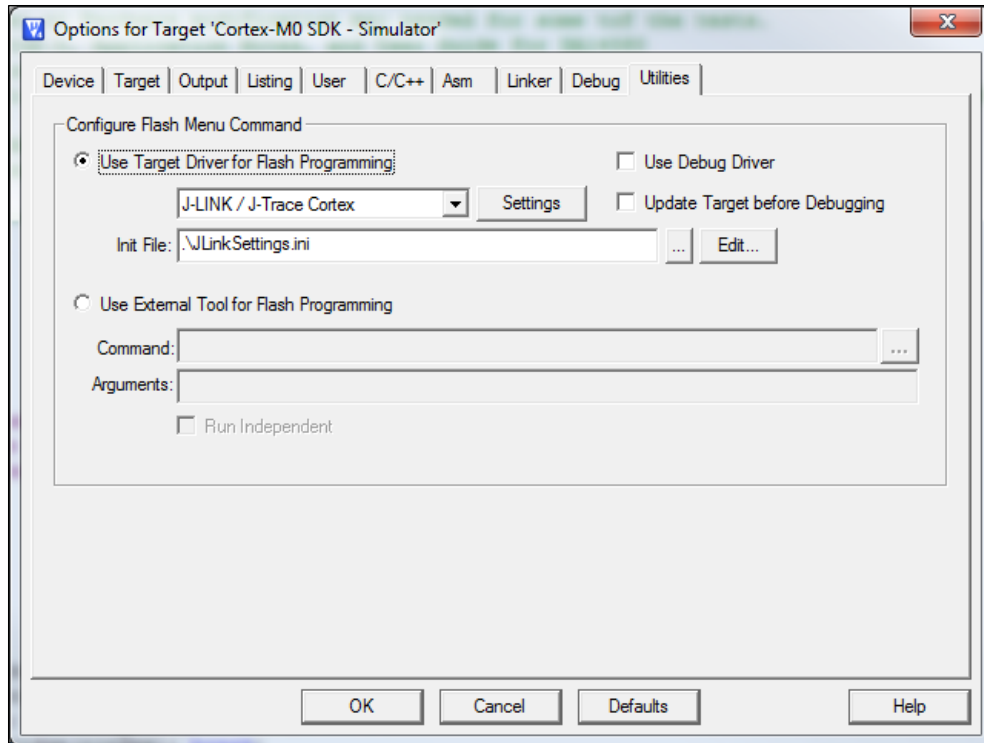

- Configure the Flash Target: Flash > Configure Flash Tools. Choose **Settings**.

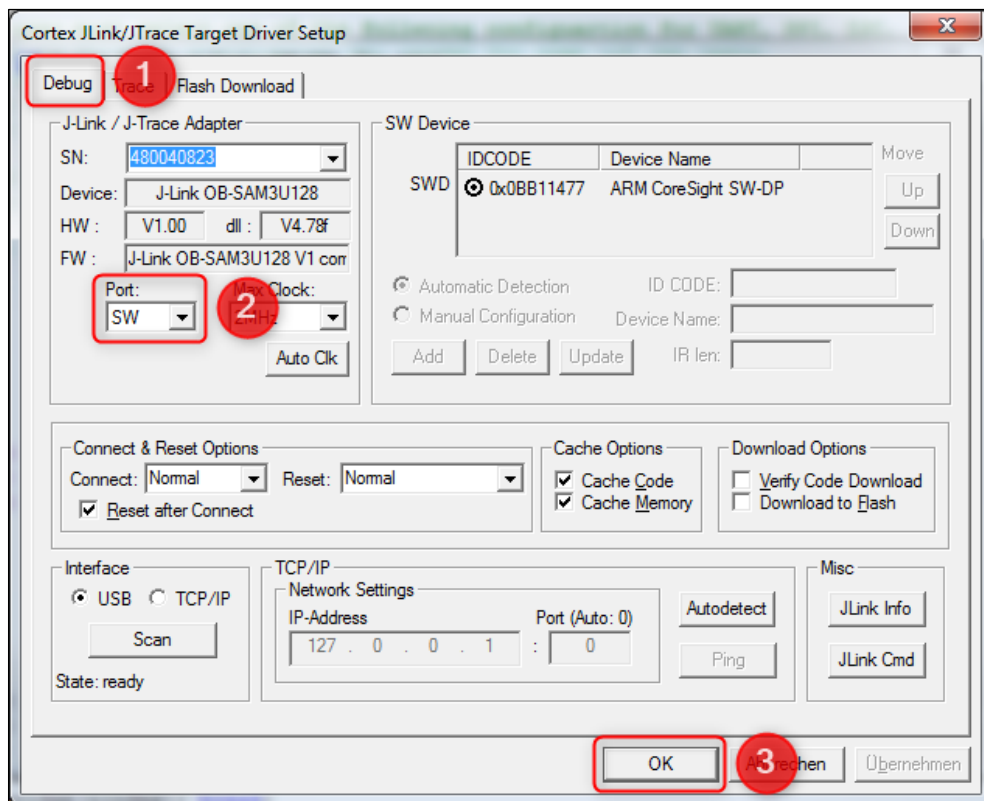

- Click on the tab **Debug** (1).



- Setup the Port to **SW** (2).
- Click **OK** (3).

8. Click on the icon **Build**  to build the target files.
9. Click on the icon **Debug**  to run the debug session.
  - ➔ The proximity project has now been compiled and downloaded into the RAM of the PAN1740A ETU.



For more detailed information on project examples, please refer to Dialog's download website <https://www.dialogs.com/>. Recommended is the proximity example as this is the most common profile.

## 7 Proximity Profile with two PAN1740A USB-Dongles (Example)

This example uses Dialog's SDK version 3.0.2.1.

The following requirement must be met:

- ✓ Microsoft® Visual C++ 2010 Express – Freeware Compiler is installed.



Use always the latest release from Dialog's website <https://www.dialogs.com/>.

### Receiver Configuration

1. Navigate to DA14580\_SDK\_3.0.2.1\dk\_apps\keil\_projects\proximity\monitor\_fe\_usb.
2. Download the image proximity/monitor\_fe\_usb into the USB-Dongle. For details please refer to ⇒ 6 Run the Keil Project (Example).
3. Open **Keil Compiler** and compile this project.

Download the .hex-file:

4. Start and stop the debug mode or load the .hex-file with the **Connection Manager**. For debug mode using the **Keil Compiler**, be sure to check the Configure Flash Tool setting described in ⇒ 6 Run the Keil Project (Example).

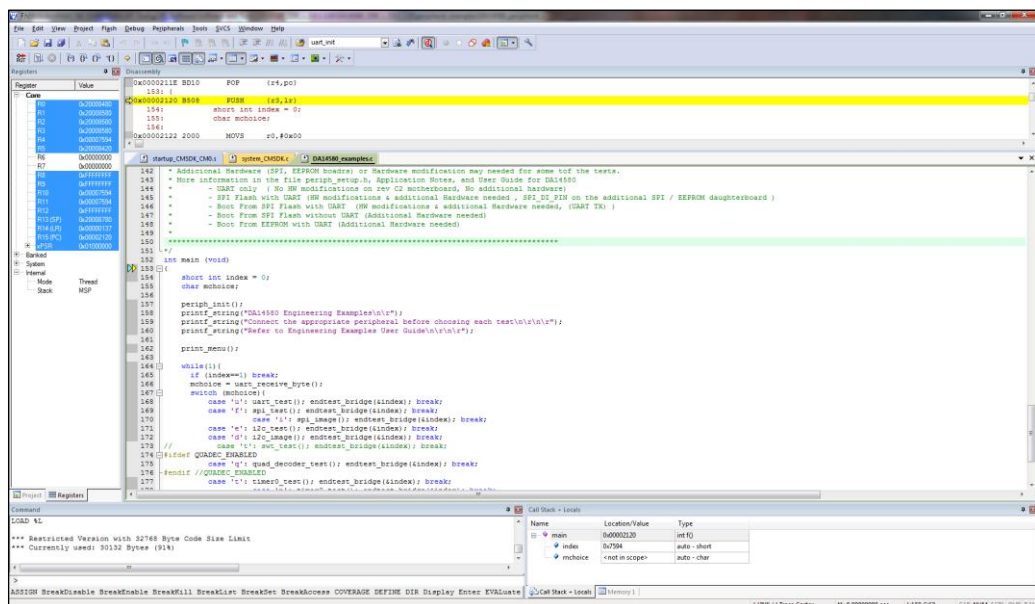



The Debug session must be stopped.

1. Open the folder `Monitor Host Application` in the SDK.
2. Open the project file `host_proxm.sln` with the Microsoft C++ Compiler.
3. Compile and run the software.
4. Determine the correct COM port using Windows® Device Manager and enter this port number in the Proximity Host application (DOS window).

```
C:\Users
#####
# DA14580 Proximity Monitor demo application #
#####
No cmdline arguments.
Enter COM port number (values: 1-65535, blank to exit): 13
Connecting to COM13
COM13 succesfully opened, baud rate 115200
Waiting for DA14580 Device
```

### Transmitter Configuration

1. Download the image `proximity/reporter_fe_usb` into the USB-Dongle.
2. Open **Keil Compiler** and compile this project.
3. Start and stop the debug mode or load the `.hex`-file with the **Connection Manager** to download the `.hex`-file.
4. Open the reporter host application.
5. Open the project file `host_proxr.sln` with the Microsoft C++ Compiler.
6. Compile and run the software.

7. Determine the correct COM port using Windows Device Manager and enter this port number in the proximity host application (DOS window).
  - The receiver side will show the connection status.
  - The USB-Dongles are connected with the proximity profile.

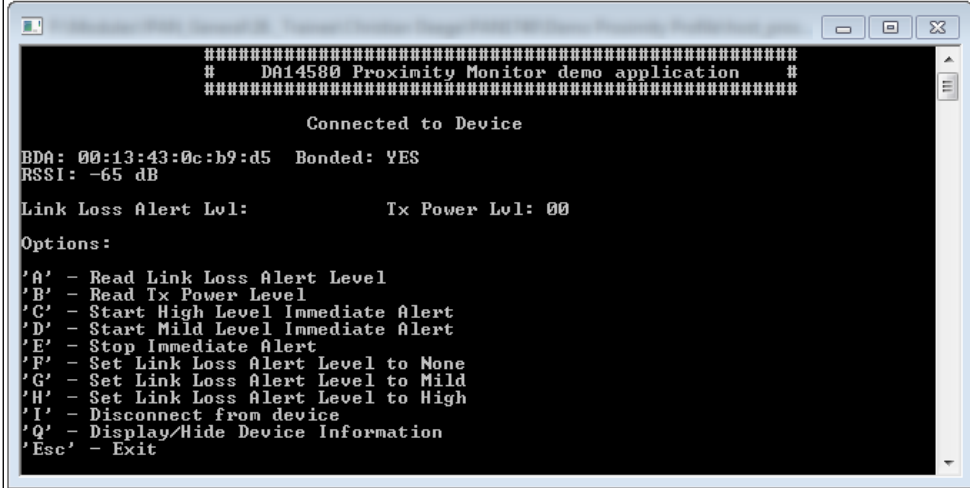

```
#####  
#   DA14580 Proximity Monitor demo application   #  
#####  
  
                Connected to Device  
  
BDA: 00:13:43:0c:b9:d5  Bonded: YES  
RSSI: -65 dB  
  
Link Loss Alert Lvl:          Tx Power Lvl: 00  
  
Options:  
'A' - Read Link Loss Alert Level  
'B' - Read Tx Power Level  
'C' - Start High Level Immediate Alert  
'D' - Start Mild Level Immediate Alert  
'E' - Stop Immediate Alert  
'F' - Set Link Loss Alert Level to None  
'G' - Set Link Loss Alert Level to Mild  
'H' - Set Link Loss Alert Level to High  
'I' - Disconnect from device  
'Q' - Display/Hide Device Information  
'Esc' - Exit
```



For more detailed information on Proximity Profile, please refer to Dialog's download website <https://www.dialogs.com/>.

## 8 Smart Snippets

The following description describes the structure and the usage of Smart Snippets in a nutshell. For more information as well as related documents, please refer to the Panasonic website

⇒ [13.2 Product Information](#).

### 8.1 Program Structure

For details, please refer to the Smart Snippets help (Help/User Guide/Sleep Mode Advisor).

#### 8.1.1 Project and Port Selection

1. Open **Smart Snippets**.
2. Select a project, the virtual COM port, and the chip version to be able to control the development kit.

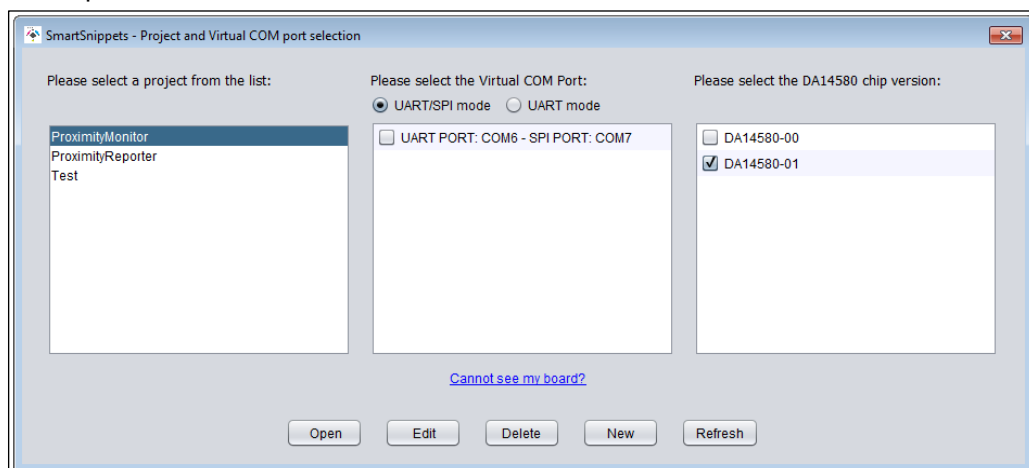

When the application launches the first time, there will be no projects to select.

Click **New** to create a new project. The name should not contain any spaces or special characters.

3. Select the chip version **DA14580** and a virtual COM port which is assigned to the connected dialog development kit.
4. Click **Open** to establish a connection to the development kit.
  - ➔ The software will show its default layout with a toolbar (Board Setup, UART Booter, Power Profiler, Sleep Mode Advisor, OTP Programmer, SPI Flash Programmer, EEPROM Programmer, and SPotA) and a few of these tools in the center of the display.

### 8.1.2 Board Setup

The tab **Board Setup** in the toolbox has to be used before any other tool as it establishes a communication with the development kit during the boot sequence and comes along with two lists.

The upper list contains UART ports with its baud rate, which connect the FTDI chip version “DA14580”. The other list selects the GPIO pin which enables 6.8 V for OTP programming.

### 8.1.3 UART Booter

The **UART Booter** enables to download application code directly into the RAM of the “DA14580” to test its behavior in terms of power consumption for instance.

1. Click **Browse** (1) to select the desired code (.bin, hex., .ihex).

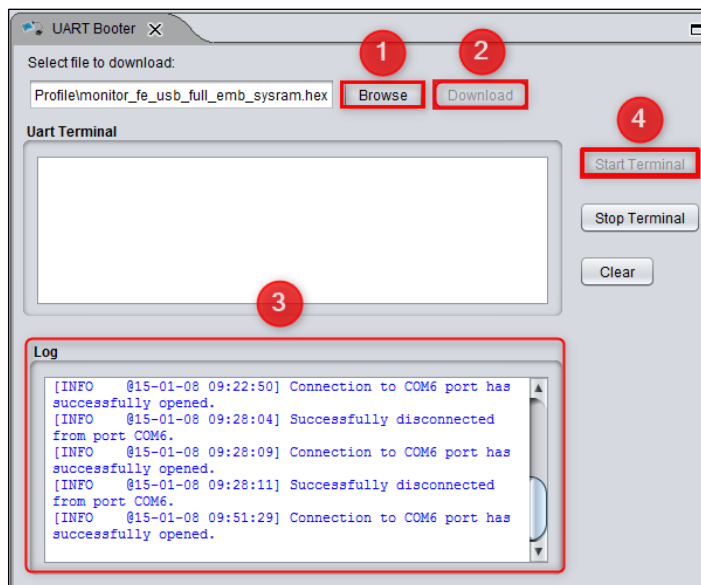

2. Click **Download** (2) and observe the **Log** (3) to handle the requested hardware reset.
3. Optional: Click **Start Terminal** (4) to receive debugging information via UART.



Note that an activated UART connection disables the OTP connection with the result that the UART connection has to be closed to enable the OTP connection and vice versa.



### 8.1.4 Power Profiler

The tool **Power Profiler** enables the user to measure the power consumption of the desired application with all its functionality.

#### Start the measurement

1. Click **Initialize**.
  - ➔ The program will be initialized and the COM port connection will be opened.
2. Click **Start**.

#### Measurement example of the Bluetooth scanning process

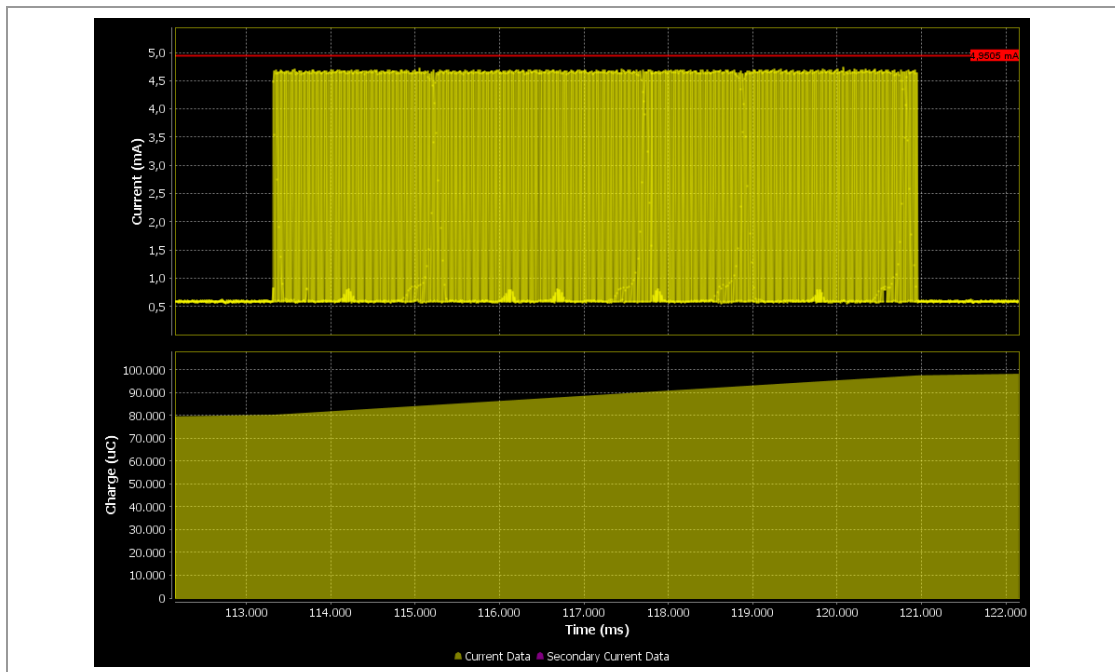

On the right side, the tool provides the measurement information about Peak Current (mA), Average Current (mA), Charge (µC) and the Sleep Mode of the current measurement.

In addition, the tool provides the following control functionalities:

#### Auto Trigger Mode

In Auto Trigger Mode the measurement process starts as soon as the current (mA) exceeds a user-definable threshold.

#### Auto Stop Mode

In Auto Stop Mode the measurement process stops automatically when the user-definable time (ms) is elapsed.

## Toolbar



The toolbar can be found in the top of Smart Snippets and enables the user to add:

- Measurements and markers
- Export/import data to/from CSV-files
- Clear secondary current data
- Take snapshots of the Power Profiler chart (.png), which can be found in the path `Dialog/Smart Snippets/Projects/UserProject`.

### 8.1.5 Sleep Mode Advisor

The tool **Sleep Mode Advisor** uses the gathered consumption data from the Power Profiler and depicts the power consumption in the sleep modes: Deep Sleep and Extended Sleep in a circle diagram. The parameters such as battery size, to obtain reliable calculation results have to be configured.

The following figure from the Smart Snippets help shows an example that prefers the Extended Sleep Mode as the battery lasts 171 days compared to 170 days in deep sleep.

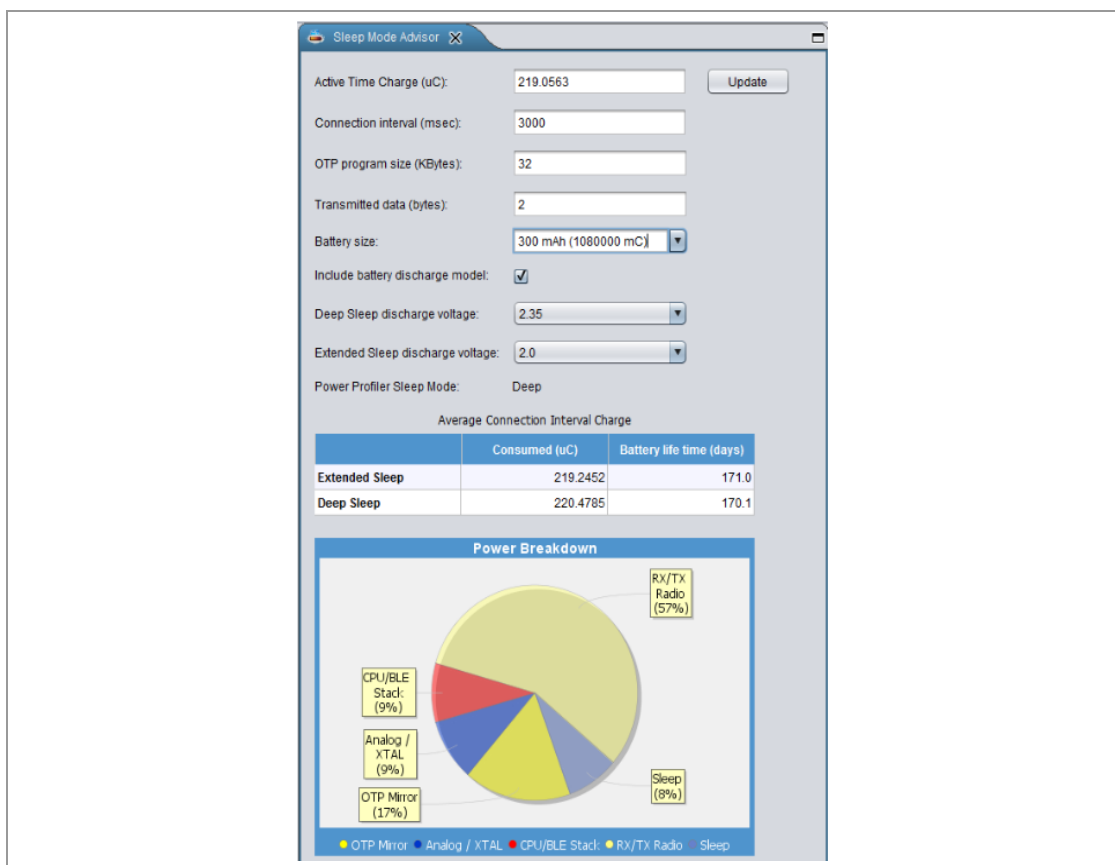

### 8.1.6 OTP Programmer, SPI Flash Programmer, and EEPROM Programmer

To burn the OTP memory and the OTP header on the “DA14580” with a user-definable .hex-, .ihex-, or .bin-file, the tool OTP Programmer is used.

The tab **OTP Image** serves the purpose to read and burn the OTP memory while the tab **OTP header** is used to validate and burn the OTP header. The tab **OTP NVDS** is used to burn the OTP NVDS memory block.

The SPI Flash Programmer enables the user to download an image file to the SPI flash memory of the “DA14580”. The functionality is similar to the OTP Programmer functionality, but the used firmware is different.

The EEPROM Programmer is used for downloading an image file to the “DA14580” EEPROM Memory similar to the OTP Programmer and SPI Flash Programmer functionality.

### 8.1.7 SPotA (Software Patch over the Air)

The tab **SPotA** can be used to execute software patches from changing a single variable in the code which resides in the SRAM to changing an instruction or data value read from the ROM used for protocol realization.



Note that a SPotA is only possible with a SPotA capable counterpart.

## 8.2 Application Demo: Proximity Profile

This application example demonstrates the usage of Smart Snippets based on the previously used proximity profile demo. Two evaluation boards “DA14580” with PAN1740A adapter boards are used which are connected to Smart Snippets.

One kit is loaded with the application code for the monitor `monitor_fe_usb_full_emb_sysram.hex` by the UART Booter. The other kit is loaded with the application code for the reporter `reporter_fe_usb_full_emb_sysram.hex`.

After that, the applications **host\_proxm\_sdk** and **host\_proxr\_sdk** will be launched and the respective COM ports will be entered and opened.

Once the devices are connected, Smart Snippets enables live evaluation of the application code for instance by measuring the power consumption as depicted below.

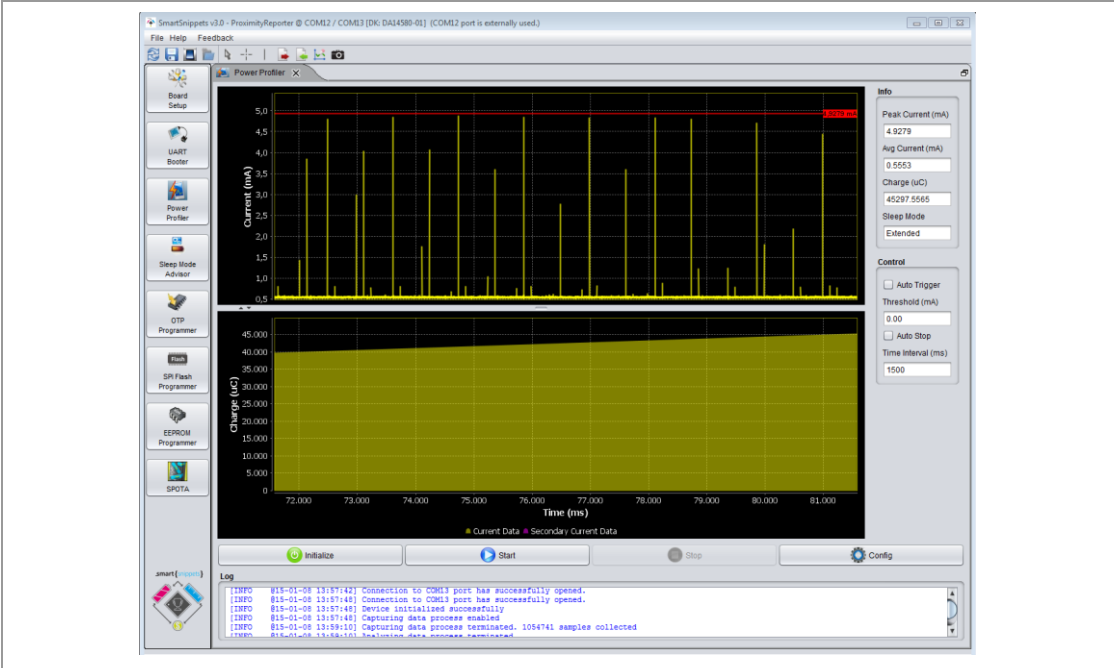
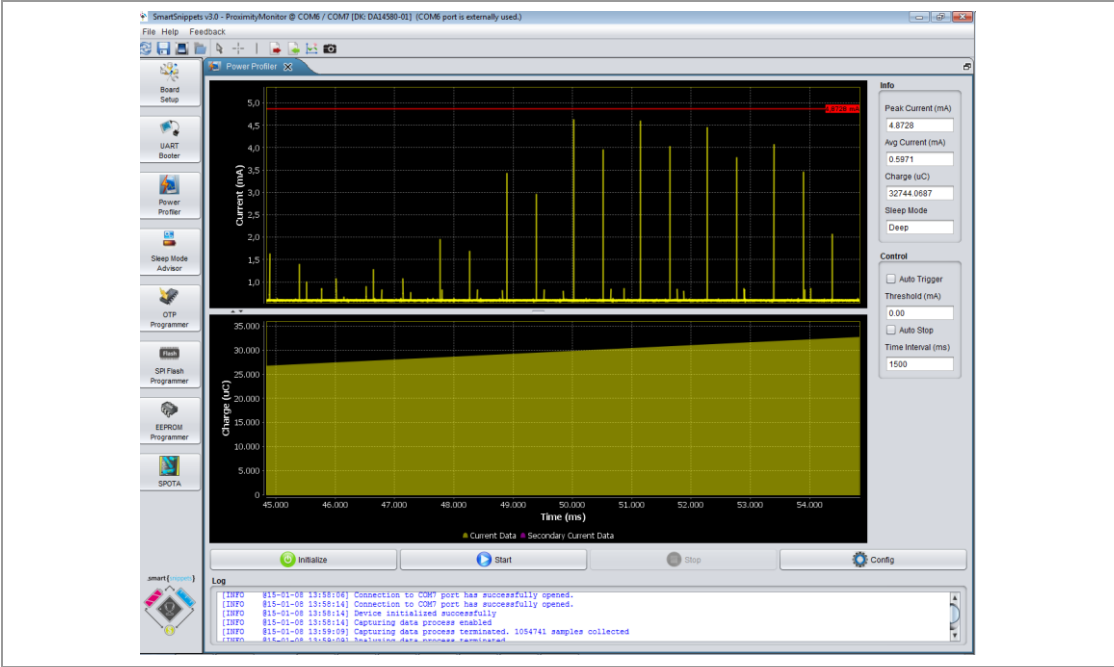

## 9 Dialog Serial Port Service (DSPS)

Dialog provides with DSPS its own Bluetooth LE communication profile. Software has been developed for the Development kit and tablets/phones allowing a serial port to be emulated between development kits, handheld devices, and PAN1740A USB sticks. This software can be downloaded from dialog's support website.

In the following are a few different examples.

### 9.1 Pro Kit with PAN1740A Adapter Board (iPod)

The following example shows an easy application of the SPS with Dialog's Pro Kit with a PAN1740A Adapter Board as device and an iPod running the DSPS application as host to exchange data.

#### 9.1.1 Set up the Pro Kit

The Pro Kit needs to be set up as device using Dialog's SPS application example **sps\_device**. The **Connection Manager** or **Smart Snippets** can be used.

The default pin assignment for the DSPS application software with hardware flow control on the Pro Kit:

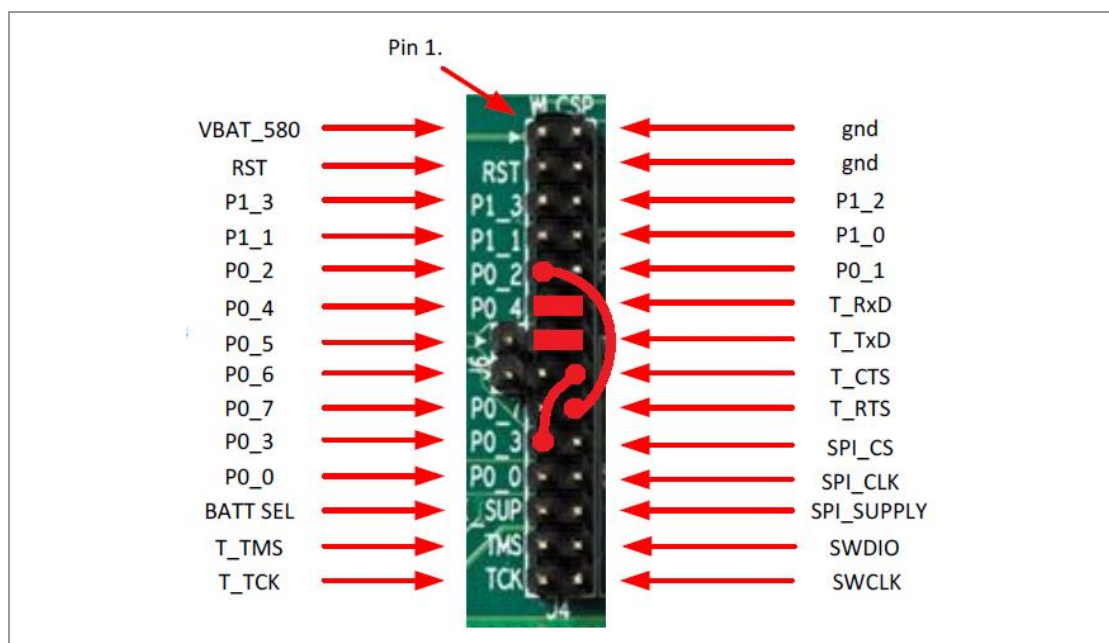

This pin assignment can be changed to any desired pin assignment in the application source code file `periph_setup.h`. To simplify the connection by using jumpers, the following pin assignment is suitable.

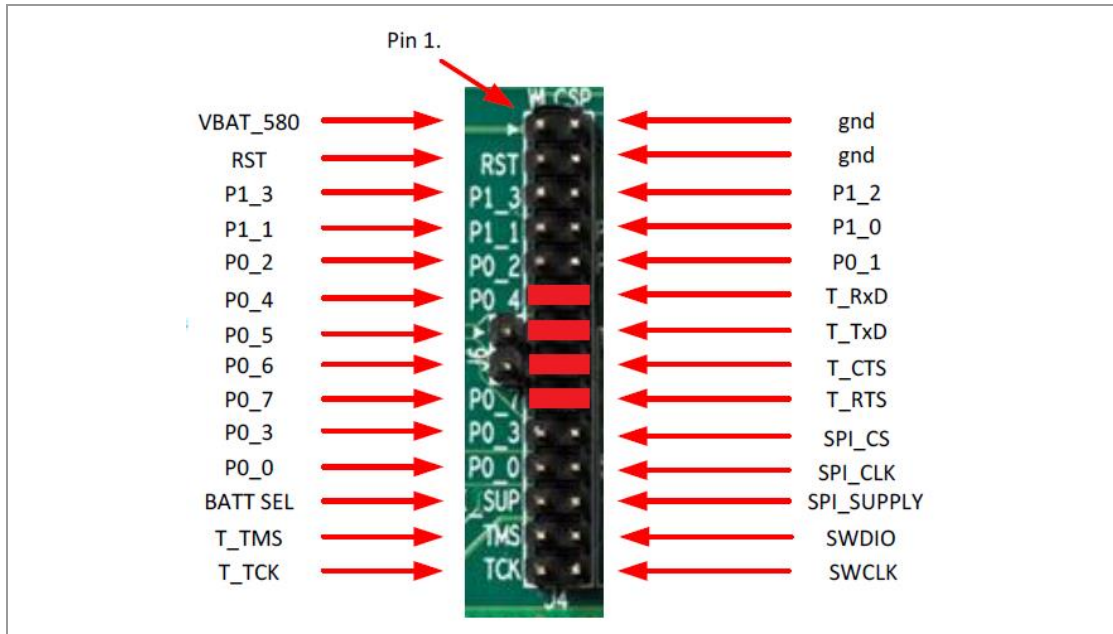

This assignment does only require a simple amendment in the code.

```
#define UART1_RTS_PORT GPIO_PORT_0
//#define UART1_RTS_PIN GPIO_PIN_3 // Previous configuration
#define UART1_RTS_PIN GPIO_PIN_6 // New configuration

#define UART1_CTS_PORT GPIO_PORT_0
//#define UART1_CTS_PIN GPIO_PIN_2 // Previous configuration
#define UART1_CTS_PIN GPIO_PIN_7 // New configuration
```

### 9.1.2 Start Dialog Serial Port Service (DSPS)

The following requirement must be met:

- ✓ The Pro Kit is set up.
1. Open the iOS application **DSPS**.
    - ➔ DSPS starts scanning automatically for discoverable devices supporting the Serial Port Service.
  2. Select the desired device to connect it.

→ The following window appears.

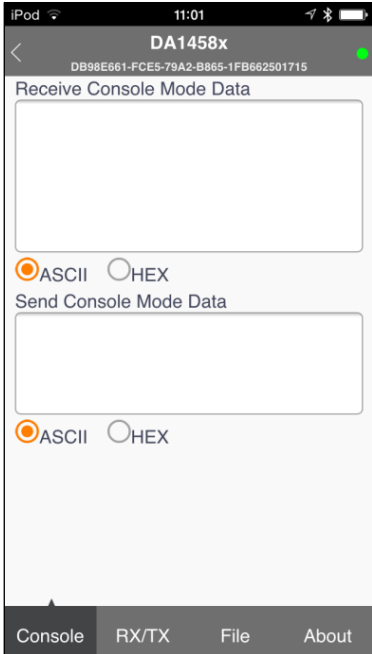

**Tab Description**

The tab **Console** enables to send data (ASCII or HEX) immediately after typing the data into the field **Send Console Mode Data** and receives data from the device, e.g. Smart Snippet UART Terminal, as shown below.

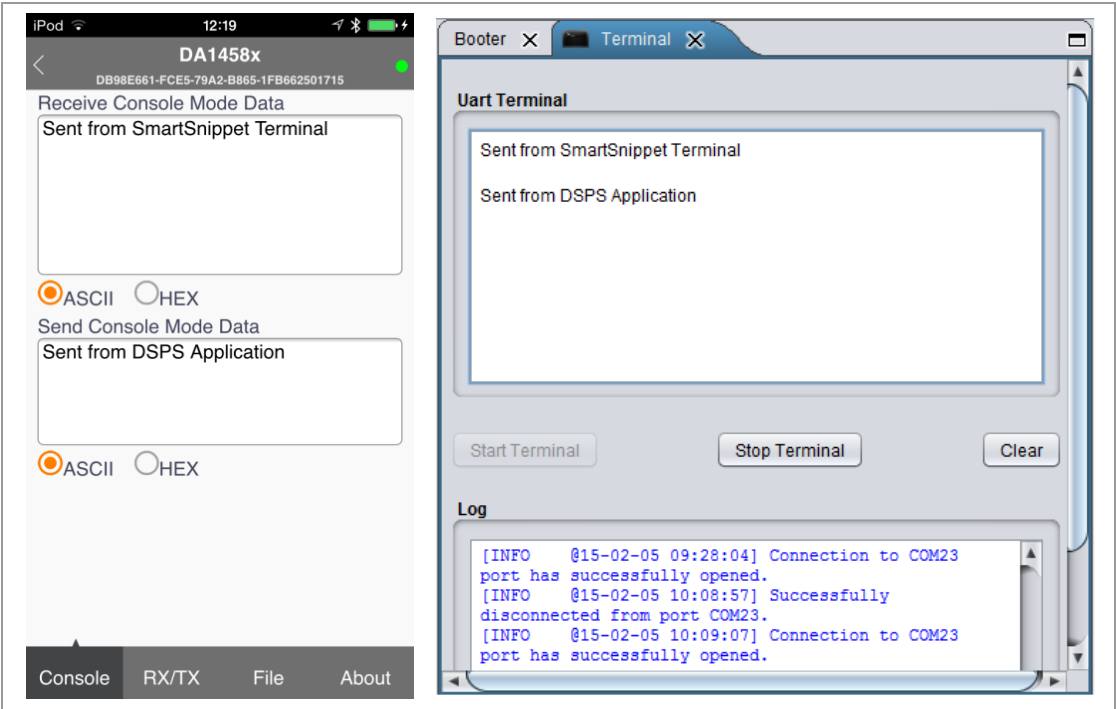

The tab **RX/TX** allows similar functionality as the tab **Console**, but enables to send data character by character manually or based on a cyclic sending interval which can be determined by the user.

The tab **File** enables to send data files instead of character strings. After the definition of a connection interval, the file directory of the device can be browsed to select the desired file.

## 9.2 Two Pro Kits with PAN1740A Adapter Board

Similar to the previous example it is possible to use two of Dialog's Pro Kits with PAN1740A Adapter Boards to emulate a serial port.



Note the hardware flow control changes (jumper or source code) required as explained in ⇒ [9.1 Pro Kit with PAN1740A Adapter Board \(iPod\)](#).

Set up one Pro Kit with the application software **sps\_device** and the other Pro Kit with the application software **sps\_host** by downloading the .hex-files onto the Pro Kits.

- ➔ The host will be discovered and connected to the device.
- ➔ A Terminal can be launched (for instance the Smart Snippet Terminal) and exchange data.

## 9.3 Two PAN1740A USB Sticks

### Establish a serial port connection with two PAN1740A USB sticks

The `da14580_config.h` of the host and the device source code has to be amended.

1. Change the flow control mode from the default hardware flow control to software flow control.

```

/* Previous configuration */
/*
#define CFG_UART_HW_FLOW_CTRL
#undef CFG_UART_SW_FLOW_CTRL

#ifdef CFG_UART_HW_FLOW_CTRL
    #undef CFG_UART_SW_FLOW_CTRL
#endif
*/

/* New configuration */
#define CFG_UART_SW_FLOW_CTRL
#undef CFG_UART_HW_FLOW_CTRL
    
```



2. Disable the sleep mode, as this is not fully supported for software flow control.

```

/*Sleep modes*/
/* Previous configuration
//#define CFG_EXT_SLEEP
*/

// New configuration
#undef CFG_EXT_SLEEP

```

3. Compile the amended source codes.
4. Download the output .hex-files onto the sticks by using Dialog's **Connection Manager** or **Keil µVision®**.



Note that it is not possible to run the sticks with Dialog's Smart Snippets.

5. Launch two terminals (e.g. Tera Term) with the corresponding COM port and the following settings:

- Baud Rate: 115 200 bps
- Data Bits: 8
- Stop Bits: 1
- Parity: None
- Flow Control: Xon/Xoff

6. Start data exchange.

➔ The data transmission happens immediately. One terminal window will stay empty for unidirectional data transfer as depicted below.

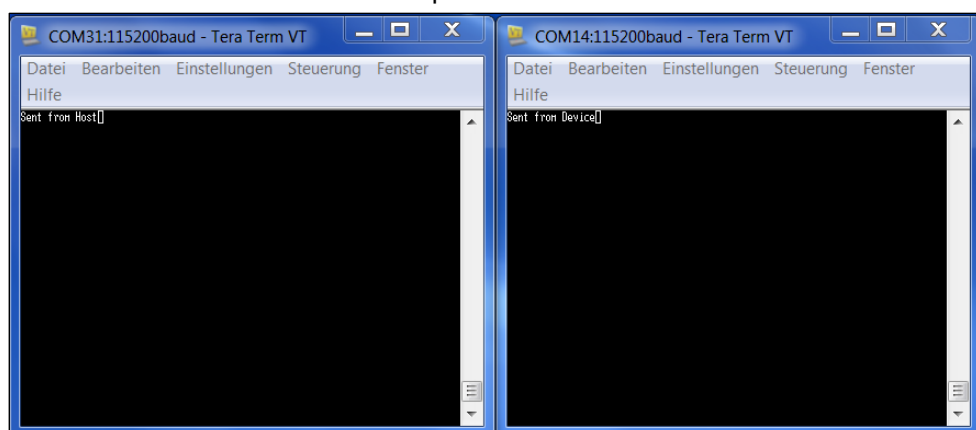

## 10 Production Tools

To program the PAN1740A in production a J-Link programmer and the 6.8 V programming voltage on the input pin VPP is required.

### Example schematic for a programming jig:

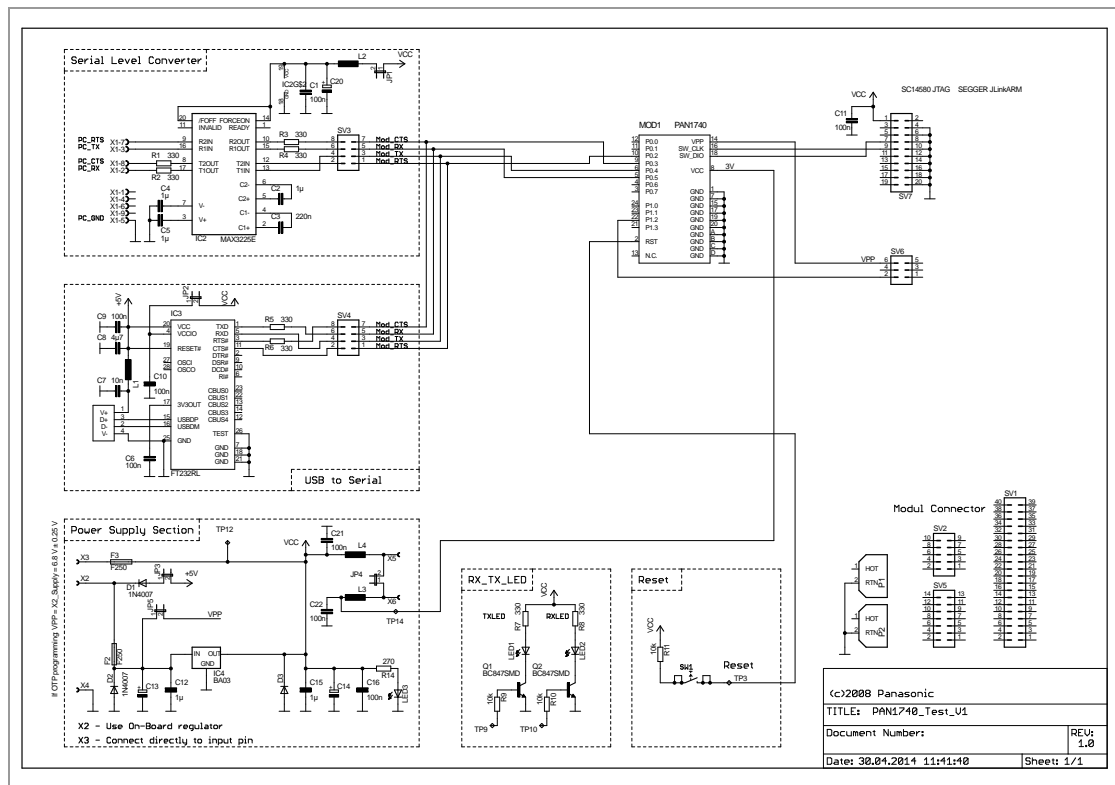

For more details on programming the OTP, please refer to the Smart Snippets website and Dialog's website.



The crystal frequency register and flag as well as the Bluetooth MAC address are already burned.

### Example of the programming into OTP:



## 11 Regulatory and Certification Information

### 11.1 General Certification Information



Regulatory certifications are valid for the following radio relevant software:

- Dialog Semiconductor ROM of chip DA14585
- Bluetooth Specification 5



For further certification requests for other radio software please contact Panasonic ⇒ [13 Contact Details](#).

### 11.2 Federal Communications Commission (FCC) for US

#### 11.2.1 FCC Statement

**The following FCC statement has to be printed in the OEM end product user information:**

The device meets the requirements for modular transmitter approval as detailed in FCC public Notice DA00-1407. The transmitter operation is subject to the following two conditions:

1. This device may not cause harmful interference, and
2. This device must accept any interference received, including interference that may cause undesired operation.

#### 11.2.2 Caution

**The following FCC caution has to be printed in the OEM end product user information:**



The FCC requires the user to be notified that any changes or modifications made to this device that are not expressly approved by Panasonic Industrial Devices Europe GmbH may void the user's authority to operate the equipment.



This equipment has been tested and found to comply with the limits for a Class B digital device, pursuant to Part 15 of the FCC Rules.

These limits are designed to provide reasonable protection against harmful interference in a residential installation. This equipment generates uses and can radiate radio frequency energy and, if not installed and used in accordance with the instructions, may cause harmful interference to radio communications.

However, there is no guarantee that interference will not occur in a particular installation. If this equipment does cause harmful interference to radio or television reception (which can be determined by turning the equipment off and on) the user is encouraged to try to correct the interference by one or more of the following measures:

- Reorient or relocate the receiving antenna,
- Increase the separation between the equipment and receiver,
- Connect the equipment into an outlet on a circuit different from that to which the receiver is connected,
- Consult the dealer or an experienced radio/TV technician for help.

### 11.2.3 Label Requirements

The following labelling requirements have to be implemented on the OEM end product:



The OEM must ensure that FCC labelling requirements are met. This includes a clearly visible label on the outside of the OEM enclosure specifying the appropriate Panasonic FCC identifier for this product as well as the FCC notice above.

The FCC identifier is **FCC ID: T7V1740A**.

This FCC identifier is valid for the PAN1740A.  
The end product must in any case be labelled on the exterior with:

"Contains FCC ID: T7V1740A "

Due to the PAN1740A model size, the FCC identifier is displayed in the installation instruction only and it cannot be displayed readable on the module's label due to the limited size.

### 11.2.4 Antenna Warning

The following Antenna has to be followed by the OEM:

This antenna warning refers to the device with the model number PAN1740A.

The device is tested with a integrated antenna listed below. When integrated into the OEM's product, these fixed antennas require installation preventing end users from replacing them with non-approved antennas. Any antenna not in the following table must be tested to comply with FCC Section 15.203 for unique antenna connectors and with Section 15.247 for emissions.

### 11.2.5 Approved Antenna List

Item	Part Number	Manufacturer	Frequency Band	Type	Max. Gain (dBi)
1	ANT016008LCS2442MA1	TDK	2.4 GHz	Chip antenna	-1.7

## 11.2.6 RF Exposure



To comply with FCC RF Exposure requirements, the OEM must ensure that only antennas from the Approved Antenna List are installed  
⇒ [11.2.5 Approved Antenna List](#).

The preceding statement must be included as a “CAUTION” statement in manuals for products operating with the approved antennas to alert users on FCC RF Exposure compliance.

Any notification to the end user of installation or removal instructions about the integrated radio module is not allowed.

The radiated output power of the PAN1740A with a mounted ceramic antenna (**FCC ID: T7V1740A**) is below the FCC radio frequency exposure limits. Nevertheless, the PAN1740A shall be used in such a manner that the potential for human contact during normal operation is minimized.

End users may not be provided with the module installation instructions. OEM integrators and end users must be provided with transmitter operating conditions for satisfying RF exposure compliance.

## 11.3 Innovation, Science, and Economic Development (ISED) for Canada

The following IC rules have to be followed by end product OEM's:

### English

The PAN1740A is licensed to meet the regulatory requirements of ISED.

License ID: **IC: 216Q-1740A**

HVIN: **ENW89852A1KF**

Manufacturers of mobile, fixed or portable devices incorporating this module are advised to clarify any regulatory questions and ensure compliance for SAR and/or RF exposure limits. Users can obtain Canadian information on RF exposure and compliance from [www.ic.gc.ca](http://www.ic.gc.ca).

This device has been designed to operate with the antennas listed in Approved Antenna List, having a maximum gain of -1.7 dBi. Antennas not included in this list or having a gain greater than -1.7 dBi are strictly prohibited for use with this device. The required antenna impedance is 50 ohms. The antenna used for this transmitter must not be co-located or operating in conjunction with any other antenna or transmitter without the need of re-assessment of conformity by ISED.

Due to the model size, the IC identifier is displayed in the installation instruction and on the package label only. It cannot be displayed readable on the module's label due to the limited size.



The end customer has to assure that the device has a distance of more than 5 mm from the human body under all circumstances.

If the end customer application intends to use the PAN1740A in a distance smaller 5 mm from the human body, SAR evaluation has to be repeated by the OEM.

The end customer equipment must meet the actual Safety/Health requirements according to ISED.

### French

PAN1740A est garanti conforme aux dispositions réglementaires d'Industry Canada (ISED).

License: **IC: 216Q-1740A**

HVIN: **ENW89852A1KF**

Il est recommandé aux fabricants d'appareils fixes, mobiles ou portables de consulter la réglementation en vigueur et de vérifier la conformité de leurs produits relativement aux limites d'exposition aux rayonnements radiofréquence ainsi qu'au débit d'absorption spécifique maximum autorisé.

Des informations pour les utilisateurs sur la réglementation Canadienne concernant l'exposition aux rayonnements RF sont disponibles sur le site [www.ic.gc.ca](http://www.ic.gc.ca).

Ce produit a été développé pour fonctionner spécifiquement avec les antennes listées dans le tableau Approved Antenna List, présentant un gain maximum de -1.7 dBi. Des antennes autres que celles listées ici, ou présentant un gain supérieur à -1.7 dBi ne doivent en aucune circonstance être utilisées en combinaison avec ce produit. L'impédance des antennes compatibles est 50 Ohm. L'antenne utilisée avec ce produit ne doit ni être située à proximité d'une autre antenne ou d'un autre émetteur, ni être utilisée conjointement avec une autre antenne ou un autre émetteur.

En raison de la taille du produit, l'identifiant IC est fourni dans le manuel d'installation.



Le client final doit s'assurer que l'appareil se trouve en toutes circonstances à une distance de plus de 5 mm du corps humain.

Si le client final envisage une application nécessitant d'utiliser le PAN1740A à une distance inférieure à 5 mm du corps humain, alors le FEO doit répéter l'évaluation DAS.

L'équipement du client final doit répondre aux exigences actuelles de sécurité et de santé selon l'ISED.

### 11.3.1 IC Notice

The following IC notice has to be printed in English and French in the OEM end product user information:

#### English



The device PAN1740A, including the integrated antenna mentioned in ⇒ [11.2.5 Approved Antenna List](#), complies with Canada RSS-GEN Rules. The device meets the requirements for modular transmitter approval as detailed in RSS-Gen.

Operation is subject to the following two conditions:

1. This device may not cause harmful interference, and
2. This device must accept any interference received, including interference that may cause undesired operation.

#### French



Le présent appareil PAN1740A, les antennes y compris ⇒ [11.2.5 Approved Antenna List](#) est conforme aux CNR-Gen d'Industrie Canada applicables aux appareils radio exempts de licence.

L'exploitation est autorisée aux deux conditions suivantes:

1. L'appareil ne doit pas produire de brouillage, et
2. L'utilisateur de l'appareil doit accepter tout brouillage radioélectrique subi, même si le brouillage est susceptible d'en compromettre le fonctionnement.

### 11.3.2 Labeling Requirements

The following IC labelling requirements have to be followed by end product OEM's:

#### English



##### Labeling Requirements

The OEM must ensure that IC labelling requirements are met. This includes a clearly visible label on the outside of the OEM enclosure specifying the appropriate Panasonic IC identifier for this product as well as the IC Notice above.

The IC identifier is: **IC: 216Q-1740A**

This IC identifier is valid for the PAN1740A module. In any case, the end product must be labelled on the exterior with:

"Contains IC: 216Q-1740A"

#### French



##### Obligations d'étiquetage

Les fabricants d'équipements d'origine (FEO) – en anglais Original Equipment Manufacturer (OEM) – doivent s'assurer que les obligations d'étiquetage IC du produit final sont remplies. Ces obligations incluent une étiquette clairement visible à l'extérieur de l'emballage externe, comportant l'identifiant IC du module Panasonic inclus, ainsi que la notification ci-dessus.

L' identifiant IC est: **IC: 216Q-1740A**

Cet identifiant est valide pour module PAN1740A. Dans tous les cas les produits finaux doivent indiquer sur leur emballage externe la mention suivante:

"Contient IC: 216Q-1740A"



## 11.4 European Conformity According to RED (2014/53/EU)



All modules described in this Module Integration Guide comply with the standards according to the following LVD (2014/35/EU), EMC-D (2014/30/EU) together with RED (2014/53/EU) articles.

### Standards

- Due to the model size, the CE marking is displayed in the installation instruction and on the package label only. It cannot be displayed according to regulation (EU) No. 765/2008 in 5 mm height on the module's label due to the limited space.
- The end product OEM has to re-assess the conformity of the end product to EU regulations, but can use the PAN1740A RED pre-assessment to shorten this procedure.
- The RED EU Type Examination Certificate No. **T818698M** issued by the Notified Body 0682 can be used for the OEM end product conformance assessment. If a Notified Body has been contracted for the end product conformity assessment, it should be noted that this EU Type Examination Certificate should be used for conformance assessment.

As a result of the OEM end product conformity assessment procedure described in 2014/53/EU Directive and other applicable EU directives, the end customer equipment should be labelled as follows:



The requirements for CE marking are described in regulation (EU) No. 765/2008 Annex II.



The end customer has to assure that the device has a distance of more than 5 mm from the human body under all circumstances.

If the end customer application intends to use the PAN1740A in a distance smaller 5 mm from the human body, SAR evaluation has to be repeated by the OEM.

The end customer equipment must meet the actual Safety/Health requirements according to RED.

PAN1740A and its model versions in the specified reference design can be used in all countries of the European Economic Area (Member States of the EU, European Free Trade Association States [Iceland, Liechtenstein, Norway]), Monaco, San Marino, Andorra, and Turkey.

## 11.5 Bluetooth

For Bluetooth end products which integrate the PAN1740A the OEM needs to apply for an own end product listing (EPL) at the Bluetooth SIG. If the PAN1740A is used on more than one OEM product, costs can be saved by applying for a family EPL.

For the end product EPL the following IDs can be used in order to avoid re-testing:

Bluetooth 5	Declaration ID	QDID
End product	D050149	148713

### Bluetooth Marks

According to the Bluetooth SIG, the PAN1740A fulfills the criteria to label your product as a Bluetooth device:



For further information please refer to the Bluetooth website [www.bluetooth.com](http://www.bluetooth.com)

## **12 Restricted Use**

### **12.1 Life Support Policy**

This Panasonic Industrial Devices Europe GmbH product is not designed for use in life support appliances, devices, or systems where malfunction can reasonably be expected to result in a significant personal injury to the user, or as a critical component in any life support device or system whose failure to perform can be reasonably expected to cause the failure of the life support device or system, or to affect its safety or effectiveness.

Panasonic customers using or selling these products for use in such applications do so at their own risk and agree to fully indemnify Panasonic Industrial Devices Europe GmbH for any damages resulting.

### **12.2 Restricted End Use**

This Panasonic Industrial Devices Europe GmbH product is not designed for any restricted activity that supports the development, production, handling usage, maintenance, storage, inventory or proliferation of any weapons or military use.

Transfer, export, re-export, usage or reselling of this product to any destination, end-user or any end-use prohibited by the European Union, United States or any other applicable law is strictly prohibited.

## 13 Contact Details

### 13.1 Contact Us

Please contact your local Panasonic Sales office for details on additional product options and services:

For Panasonic Sales assistance in the **EU**, visit

<https://eu.industrial.panasonic.com/about-us/contact-us>

Email: [wireless@eu.panasonic.com](mailto:wireless@eu.panasonic.com)

For Panasonic Sales assistance in **North America**, visit the Panasonic website “Sales & Support” to find assistance near you at

<https://na.industrial.panasonic.com/distributors>

Please visit the **Panasonic Wireless Technical Forum** to submit a question at

<https://forum.na.industrial.panasonic.com>

### 13.2 Product Information

Please refer to the Panasonic Wireless Connectivity website for further information on our products and related documents:

For complete Panasonic product details in the **EU**, visit

<http://pideu.panasonic.de/products/wireless-modules.html>

For complete Panasonic product details in **North America**, visit

<http://www.panasonic.com/rfmodules>