

PAN1781

Bluetooth® Low Energy Module
Module Integration Guide

Rev. 1.1



Overview

The PAN1781 is a Bluetooth 5.1 Low Energy (LE) module based on the Nordic nRF52820 single chip controller.

Features

- Surface mount type dimensions: 15.6 mm × 8.7 mm × 2 mm
- Drop-in replacement for PAN1026A and PAN1762
- Nordic nRF52820 featuring ARM Cortex®-M4 with 64 MHz
- Bluetooth 5.1 LE including LE 2M and LE Coded PHY
- Embedded 256 kB flash memory and 32 kB internal RAM
- 128-bit AES/ECB/CCM/AAR co-processor
- Up to 16 General Purpose I/O's (GPIO), which are shared with up to 2× SPI, 2× I²C, UART, COMP, QDEC, nRESET
- USB 2.0 full-speed device interface
- Built-in temperature sensor

Bluetooth

- LE 2 Mbps high speed PHY, LE long range coded PHY
- LE advertising extensions (advertising on 40 channels total)
- Channel selection algorithm #2
- LE secure connections
- Angle of arrival (AoA) and angle of departure (AoD) direction finding

Characteristics

- Typical sensitivity: -95 dBm at 1 Mb/s and -103 dBm at 125 kb/s
- Typical max. output power: 8 dBm, configurable from -20 dBm in 4 dB steps and -40 dBm in whisper mode
- Typical current consumption: 4.9 mA in Tx (at 0 dBm) and 4.7 mA in Rx mode
- Typical current consumption: 0.3 µA in System OFF mode, 1.2 µA with RTC wake up
- On-module DC/DC and LDO regulators with automated low current modes
- Voltage range: 1.7 V to 5.5 V
- Temperature range: -40 °C to 85 °C

Block Diagram

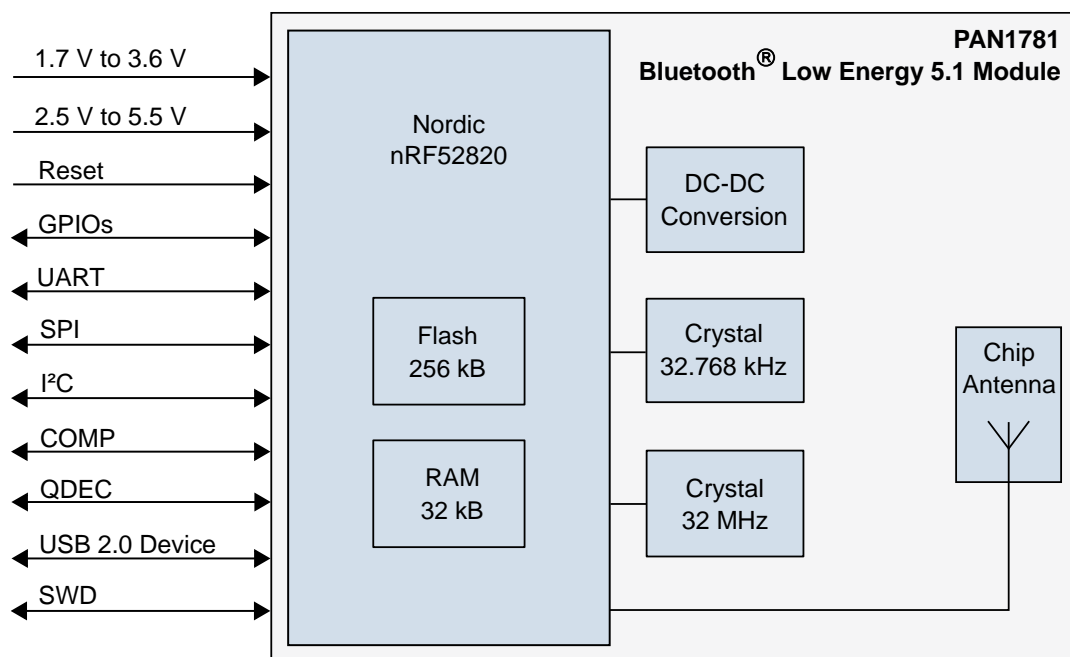

By purchase of any of the products described in this document the customer accepts the document's validity and declares their agreement and understanding of its contents and recommendations. Panasonic Industrial Devices Europe GmbH (Panasonic) reserves the right to make changes as required at any time without notification. Please consult the most recently issued Module Integration Guide before initiating or completing a design.

© Panasonic Industrial Devices Europe GmbH 2021.

This specification sheet is copyrighted. Reproduction of this document is permissible only if reproduction is without alteration and is accompanied by all associated warranties, conditions, limitations, and notices. Do not disclose it to a third party.

All rights reserved.

This Module Integration Guide does not lodge the claim to be complete and free of mistakes.

Engineering Samples (ES)

If Engineering Samples are delivered to the customer, these samples have the status "Engineering Samples". This means that the design of this product is not yet concluded. Engineering Samples may be partially or fully functional, and they may differ from the published Product Specification.

Engineering Samples are not qualified and they are not to be used for reliability testing or series production.

Disclaimer

The customer acknowledges that samples may deviate from the Module Integration Guide and may bear defects due to their status of development and the lack of qualification mentioned above.

Panasonic rejects any liability or product warranty for Engineering Samples. In particular, Panasonic disclaims liability for damages caused by:

- The use of the Engineering Sample other than for evaluation purposes, particularly the installation or integration in another product to be sold by the customer,
- Deviation or lapse in function of the Engineering Sample,
- Improper use of the Engineering Sample.

Panasonic Industrial Devices Europe GmbH disclaims any liability for consequential and incidental damages. In case of any queries regarding the Engineering Samples, please contact your local sales partner or the related product manager.

The information contained herein is presented only as guidance for Product use. No responsibility is assumed by Panasonic for any infringement of patents or any other intellectual property rights of third parties that may result from the use of Product. No license to any intellectual property right is granted by this document, whether express or implied, by estoppel or otherwise.

Description of hardware, software, and other information in this document is only intended to illustrate the functionality of the referred Panasonic product. It should not be construed as guaranteeing specific functionality of the product as described or suitable for a particular application.

Any provided (source) code shall not be used or incorporated into any products or systems whose manufacture, use or sale is prohibited under any applicable laws or regulations.

Any outlined or referenced (source) code within this document is provided on an "as is" basis without any right to technical support or updates and without warranty of any kind on a free of charge basis according to § 516 German Civil Law (BGB) including without limitation, any warranties or conditions of title, non infringement, merchantability, or fitness for a particular purpose. Customer acknowledges that (source) code may bear defects and errors.

The third-party tools mentioned in this document are offered by independent third-party providers who are solely responsible for these products. Panasonic has no responsibility whatsoever for the performance, product descriptions, specifications, referenced content, or any and all claims or representations of these third-party providers. Panasonic makes no warranty whatsoever, neither express nor implied, with respect to the goods, the referenced contents, or any and all claims or representations of the third-party providers. To the maximum extent allowable by Law Panasonic assumes no liability whatsoever including without limitation, indirect, consequential, special, or incidental damages or loss, including without limitation loss of profits, loss of opportunities, business interruption, and loss of data.

Table of Contents

- 1 About This Document.....6**
 - 1.1 Purpose and Audience6
 - 1.2 Revision History.....6
 - 1.3 Use of Symbols6
 - 1.4 Related Documents7

- 2 Overview.....8**

- 3 PAN1781 Module.....9**
 - 3.1 Block Diagram9
 - 3.2 Footprint10
 - 3.3 Placement.....11

- 4 Regulatory and Certification Information13**
 - 4.1 General Certification Information13
 - 4.2 Federal Communications Commission (FCC) for US13
 - 4.3 Innovation, Science, and Economic Development (ISED) for Canada16
 - 4.4 European Conformity According to RED (2014/53/EU)20
 - 4.5 Japanese Radio Law Compliance21
 - 4.6 China (Label Requirements).....22
 - 4.7 Korea (Label Requirements).....23
 - 4.8 Australia and New Zealand Conformity according to RCM.....24
 - 4.9 Bluetooth25

- 5 Contact Details.....26**
 - 5.1 Contact Us.....26
 - 5.2 Product Information26

1 About This Document

1.1 Purpose and Audience

This Module Integration Guide is intended to support the easy integration of the PAN1781 into a product and to ensure the compliance with regulatory requirements. It gives an overview about the hardware design requirements

It is intended for hardware design, application, and Original Equipment Manufacturers (OEM) engineers.



Please read this guide carefully to assure the compliance of your product to regulatory.

The product is referred to as “the PAN1781” or “the module” within this document.

1.2 Revision History

Revision	Date	Modifications/Remarks
1.0	2021-04-22	First version
1.1	2021-11-02	Updated Bluetooth version. Added country certifications information for Japan, Korea, China, New Zealand, Australia.

1.3 Use of Symbols

Symbol	Description
	Note Indicates important information for the proper use of the product. Non-observance can lead to errors.
	Attention Indicates important notes that, if not observed, can put the product's functionality at risk.
	Tip Indicates useful information designed to facilitate working with the module and software.
⇒ [chapter number] [chapter title]	Cross Reference Indicates cross references within the document. Example: Description of the symbols used in this document ⇒ 1.3 Use of Symbols.
✓	Requirement Indicates a requirement that must be met before the corresponding tasks can be completed.
→	Result Indicates the result of a task or the result of a series of tasks.

Symbol	Description
This font	<p>GUI Text</p> <p>Indicates fixed terms and text of the graphical user interface.</p> <p>Example:</p> <p>Click Save.</p>
Menu > Menu item	<p>Path</p> <p>Indicates a path, e.g. to access a dialog.</p> <p>Example:</p> <p>In the menu, select File > Setup page.</p>
This font	<p>File Names, Messages, User Input</p> <p>Indicates file names or messages and information displayed on the screen or to be selected or entered by the user.</p> <p>Examples:</p> <p><code>pan1760.c</code> contains the actual module initialization.</p> <p>The message <code>Failed to save your data</code> is displayed.</p> <p>Enter the value <code>Product 123</code>.</p>
Key	<p>Key</p> <p>Indicates a key on the keyboard, e.g. F10.</p>

1.4 Related Documents

For related documents please refer to the Panasonic website ⇒ [5.2 Product Information](#).

2 Overview

The PAN1781 is a Bluetooth 5.1 Low Energy (LE) module based on the Nordic nRF52820 single chip controller.

The Bluetooth 5.1 features additionally a higher symbol rate of 2 Mbps using the high speed LE 2M PHY or a significantly longer range using the LE coded PHY at 500 kb/s or 125 kb/s. The new channel selection algorithm (CSA#2) improves the performance in high interference environments. Furthermore, the new LE advertising extensions allow for much larger amounts of data to be broadcasted in connectionless scenarios.

An output power of up to 8 dBm and the high sensitivity of the nRF52820 in combination with the LE coded PHY make the module very attractive in applications, where a long range is required.

In addition, the ultra-low current consumption of the PAN1781 makes the module an ideal choice for battery powered devices.

With the Cortex-M4 processor, 32 kB RAM, and the built-in 256 kB flash memory, the PAN1781 can easily be used in standalone mode, thereby eliminating the need for an external processor, saving complexity, space, and cost.

The PAN1781 also supports angle of arrival (AoA) and angle of departure (AoD) direction finding using Bluetooth.

A 128-bit AES/ECB/CCM/AAR co-processor may be used for on-the-fly packet encryption.

For related documents please refer to [⇒ 5.2 Product Information](#).

3 PAN1781 Module

3.1 Block Diagram

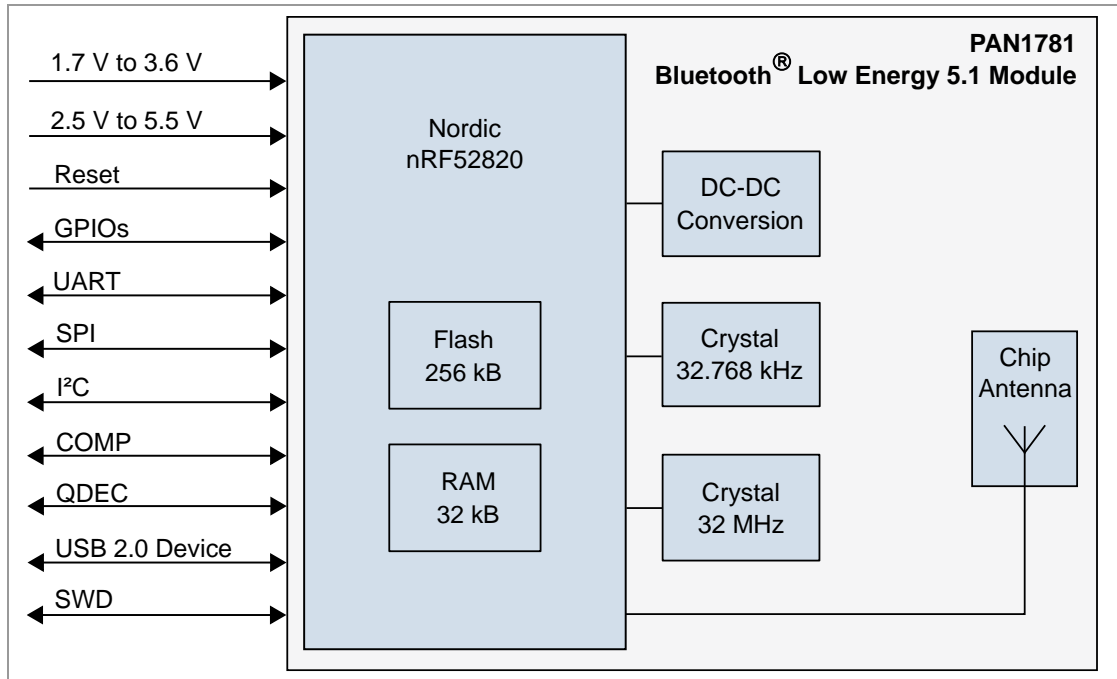

3.2 Footprint

 The dimensions are in millimeters.
The outer dimensions have a tolerance of ± 0.3 mm.

Top View

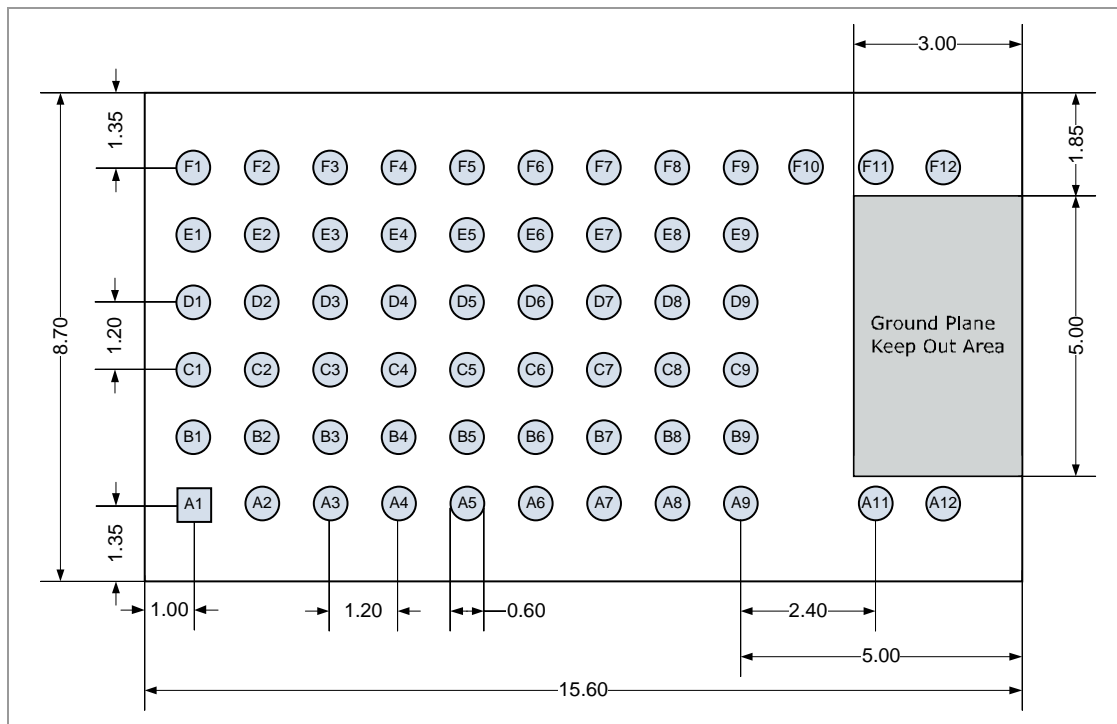

3.3 Placement



Antenna “Keep out Area”

Do not place any ground plane under the marked restricted antenna area in any layer! This would be affecting the performance of the chip antenna in a critical manner.



Impact of Placement on the Antenna Radiation Pattern

The placement of the module, surrounding material, and customer components has an impact on the radiation pattern of the antenna.



The recommendation for the ground plane is based on a FR4 4-Layer PCB.

The following requirements must be met:

- ✓ The supply voltage must be free of AC ripple voltage (for example from a battery or a low noise regulator output). For noisy supply voltages, provide a decoupling circuit (for example a ferrite in series connection and a bypass capacitor to ground of at least 47 μ F directly at the module).
- ✓ This module should not be mechanically stressed when installed.
- ✓ Keep this module away from heat. Heat is the major cause of decreasing the life time of these modules.
- ✓ Avoid assembly and use of the target equipment in conditions where the module temperature may exceed the maximum tolerance.
- ✓ Keep this module away from other high frequency circuits.
- ✓ Refer to the recommended pattern when designing a board.

The antenna requires a cutout area of 5 mm \times 3 mm under the PAN1781 module. This “Keep out Area” shall be located in every layer under the module antenna.

It is recommended to verify the perfect position of the module in the target application before fixing the design.



All dimensions are in millimeters.



Use a ground plane in the area surrounding the module wherever possible.

It is recommended to place the module:

- In the center (horizontal) of mother PCB.
- At the edge (horizontal) of mother PCB.

Antenna Placement Recommendation

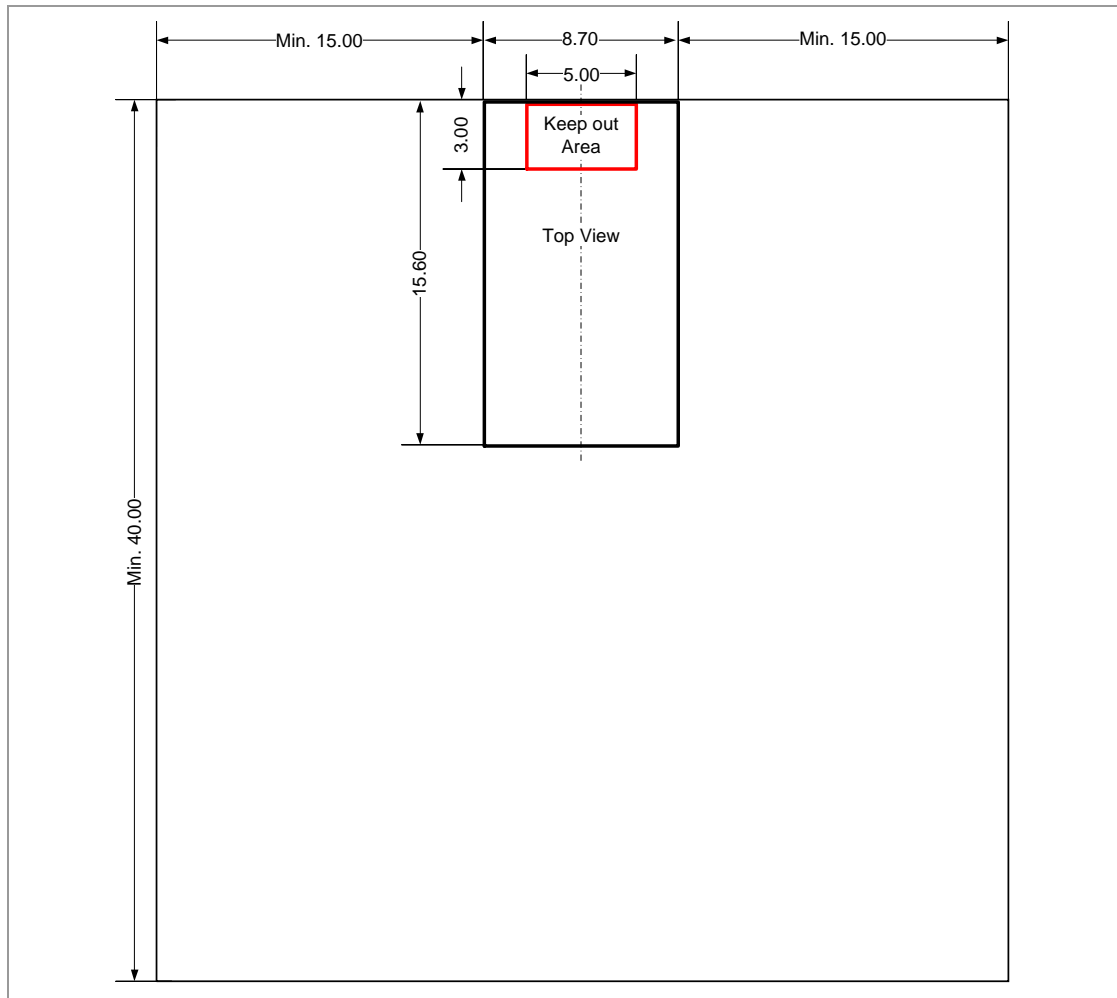

4 Regulatory and Certification Information

4.1 General Certification Information



Regulatory certifications are valid for the following radio relevant software:

- Nordic SoftDevices S112, S113, or S140
- Bluetooth Specification 5



For further certification requests for other radio software please contact Panasonic ⇒ [5 Contact Details](#).

4.2 Federal Communications Commission (FCC) for US

4.2.1 FCC Statement

The following FCC statement has to be printed in the OEM end product user information:

The device meets the requirements for modular transmitter approval as detailed in FCC public Notice DA00-1407. The transmitter operation is subject to the following two conditions:

1. This device may not cause harmful interference, and
2. This device must accept any interference received, including interference that may cause undesired operation.

4.2.2 Caution

The following FCC caution has to be printed in the OEM end product user information:



The FCC requires the user to be notified that any changes or modifications made to this device that are not expressly approved by Panasonic Industrial Devices Europe GmbH may void the user's authority to operate the equipment.



This equipment has been tested and found to comply with the limits for a Class B digital device, pursuant to Part 15 of the FCC Rules.

These limits are designed to provide reasonable protection against harmful interference in a residential installation. This equipment generates uses and can radiate radio frequency energy and, if not installed and used in accordance with the instructions, may cause harmful interference to radio communications.

However, there is no guarantee that interference will not occur in a particular installation. If this equipment does cause harmful interference to radio or television reception (which can be determined by turning the equipment off and on) the user is encouraged to try to correct the interference by one or more of the following measures:

- Reorient or relocate the receiving antenna,
- Increase the separation between the equipment and receiver,
- Connect the equipment into an outlet on a circuit different from that to which the receiver is connected,
- Consult the dealer or an experienced radio/TV technician for help.

4.2.3 Label Requirements

The following labelling requirements have to be implemented on the OEM end product:



The OEM must ensure that FCC labelling requirements are met. This includes a clearly visible label on the outside of the OEM enclosure specifying the appropriate Panasonic FCC identifier for this product as well as the FCC notice above.

The FCC identifier is **FCC ID: T7V1781**.

This FCC identifier is valid for the PAN1781.

The end product must in any case be labelled on the exterior with:

"Contains FCC ID: T7V1781"

Due to the PAN1781 model size, the FCC identifier is displayed in the installation instruction only and it cannot be displayed readable on the module's label due to the limited size.

4.2.4 Antenna Warning

The following antenna has to be followed by the OEM:

This antenna warning refers to the device with the model number PAN1781.

The device is tested with a integrated antenna listed below. When integrated into the OEM's product, these fixed antennas require installation preventing end users from replacing them with non-approved antennas. Any antenna not in the following table must be tested to comply with FCC Section 15.203 for unique antenna connectors and with Section 15.247 for emissions.

4.2.5 Approved Antenna List

Item	Part Number	Manufacturer	Frequency Band	Type	Max. Gain (dBi)
1	ANT016008LCS2442MA1	TDK	2.4 GHz	Chip Antenna	+2

4.2.6 RF Exposure



To comply with FCC RF Exposure requirements, the OEM must ensure that only antennas from the Approved Antenna List are installed ⇒ [4.2.5 Approved Antenna List](#).

The preceding statement must be included as a “CAUTION” statement in manuals for products operating with the approved antennas to alert users on FCC RF Exposure compliance.

Any notification to the end user of installation or removal instructions about the integrated radio module is not allowed.

The radiated output power of the PAN1781 with a mounted ceramic antenna (**FCC ID: T7V1781**) is below the FCC radio frequency exposure limits. Nevertheless, the PAN1781 shall be used in such a manner that the potential for human contact during normal operation is minimized.

End users may not be provided with the module installation instructions. OEM integrators and end users must be provided with transmitter operating conditions for satisfying RF exposure compliance.

4.3 Innovation, Science, and Economic Development (ISED) for Canada

The following IC rules have to be followed by end product OEM's:

English

The PAN1781 is licensed to meet the regulatory requirements of ISED.

License ID: **IC: 216Q-1781**

HVIN: **ENW89857A1KF, ENW89857A2KF**

Manufacturers of mobile, fixed or portable devices incorporating this module are advised to clarify any regulatory questions and ensure compliance for SAR and/or RF exposure limits. Users can obtain Canadian information on RF exposure and compliance from www.ic.gc.ca.

This device has been designed to operate with the antennas listed in Approved Antenna List, having a maximum gain of +2 dBi. Antennas not included in this list or having a gain greater than +2 dBi are strictly prohibited for use with this device. The required antenna impedance is 50 ohms. The antenna used for this transmitter must not be co-located or operating in conjunction with any other antenna or transmitter without the need of re-assessment of conformity by ISED.

Due to the model size, the IC identifier is displayed in the installation instruction and on the package label only. It cannot be displayed readable on the module's label due to the limited size.



The end customer has to assure that the device has a distance of more than 10 mm from the human body under all circumstances.

If the end customer application intends to use the PAN1781 in a distance smaller 10 mm from the human body, SAR evaluation has to be repeated by the OEM.

The end customer equipment must meet the actual Safety/Health requirements according to ISED.

French

PAN1781 est garanti conforme aux dispositions réglementaires d'Industry Canada (ISED).

License: **IC: 216Q-1781**

HVIN: **ENW89857A1KF, ENW89857A2KF**

Il est recommandé aux fabricants d'appareils fixes, mobiles ou portables de consulter la réglementation en vigueur et de vérifier la conformité de leurs produits relativement aux limites d'exposition aux rayonnements radiofréquence ainsi qu'au débit d'absorption spécifique maximum autorisé.

Des informations pour les utilisateurs sur la réglementation Canadienne concernant l'exposition aux rayonnements RF sont disponibles sur le site www.ic.gc.ca.

Ce produit a été développé pour fonctionner spécifiquement avec les antennes listées dans le tableau Approved Antenna List, présentant un gain maximum de + 2 dBi. Des antennes autres que celles listées ici, ou présentant un gain supérieur à + 2 dBi ne doivent en aucune circonstance être utilisées en combinaison avec ce produit. L'impédance des antennes compatibles est 50 Ohm. L'antenne utilisée avec ce produit ne doit ni être située à proximité d'une autre antenne ou d'un autre émetteur, ni être utilisée conjointement avec une autre antenne ou un autre émetteur.

En raison de la taille du produit, l'identifiant IC est fourni dans le manuel d'installation.



Le client final doit s'assurer que l'appareil se trouve en toutes circonstances à une distance de plus de 10 mm du corps humain.

Si le client final envisage une application nécessitant d'utiliser le PAN1781 à une distance inférieure à 10 mm du corps humain, alors le FEO doit répéter l'évaluation DAS.

L'équipement du client final doit répondre aux exigences actuelles de sécurité et de santé selon l'ISED.

4.3.1 IC Notice

The following IC notice has to be printed in English and French in the OEM end product user information:

English



The device PAN1781, including the integrated antenna mentioned in ⇒ [4.2.5 Approved Antenna List](#), complies with Canada RSS-GEN Rules. The device meets the requirements for modular transmitter approval as detailed in RSS-Gen.

Operation is subject to the following two conditions:

1. This device may not cause harmful interference, and
2. This device must accept any interference received, including interference that may cause undesired operation.

French



Le présent appareil PAN1781, les antennes y compris ⇒ [4.2.5 Approved Antenna List](#) est conforme aux CNR-Gen d'Industrie Canada applicables aux appareils radio exempts de licence.

L'exploitation est autorisée aux deux conditions suivantes:

1. L'appareil ne doit pas produire de brouillage, et
2. L'utilisateur de l'appareil doit accepter tout brouillage radioélectrique subi, même si le brouillage est susceptible d'en compromettre le fonctionnement.

4.3.2 Labeling Requirements

The following IC labelling requirements have to be followed by end product OEM's:

English



Labeling Requirements

The OEM must ensure that IC labelling requirements are met. This includes a clearly visible label on the outside of the OEM enclosure specifying the appropriate Panasonic IC identifier for this product as well as the IC Notice above.

The IC identifier is: **IC: 216Q-1781**

This IC identifier is valid for the PAN1781 module. In any case, the end product must be labelled on the exterior with:

"Contains IC: 216Q-1781"

French



Obligations d'étiquetage

Les fabricants d'équipements d'origine (FEO) – en anglais Original Equipment Manufacturer (OEM) – doivent s'assurer que les obligations d'étiquetage IC du produit final sont remplies. Ces obligations incluent une étiquette clairement visible à l'extérieur de l'emballage externe, comportant l'identifiant IC du module Panasonic inclus, ainsi que la notification ci-dessus.

L'identifiant IC est: **IC: 216Q-1781**

Cet identifiant est valide pour module PAN1781. Dans tous les cas les produits finaux doivent indiquer sur leur emballage externe la mention suivante:

"Contient IC: 216Q-1781"

4.4 European Conformity According to RED (2014/53/EU)



All modules described in this Module Integration Guide comply with the standards according to the following LVD (2014/35/EU), EMC-D (2014/30/EU) together with RED (2014/53/EU) articles.

Standards

- Due to the model size, the CE marking is displayed in the installation instruction and on the package label only. It cannot be displayed according to regulation (EU) No. 765/2008 in 5 mm height on the module's label due to the limited space.
- The end product OEM has to re-assess the conformity of the end product to EU regulations, but can use the PAN1781 RED pre-assessment to shorten this procedure.
- The RED EU Type Examination Certificate No. **T818833N-01-TEC** issued by the Notified Body 0682 can be used for the OEM end product conformance assessment. If a Notified Body has been contracted for the end product conformity assessment, it should be noted that this EU Type Examination Certificate should be used for conformance assessment.

As a result of the OEM end product conformity assessment procedure described in 2014/53/EU Directive and other applicable EU directives, the end customer equipment should be labelled as follows:



The requirements for CE marking are described in regulation (EU) No. 765/2008 Annex II.



The end customer has to assure that the device has a distance of more than 5 mm from the human body under all circumstances.

If the end customer application intends to use the PAN1781 in a distance smaller 5 mm from the human body, SAR evaluation has to be repeated by the OEM.

The end customer equipment must meet the actual Safety/Health requirements according to RED.

PAN1781 and its model versions in the specified reference design can be used in all countries of the European Economic Area (Member States of the EU, European Free Trade Association States [Iceland, Liechtenstein, Norway]), Monaco, San Marino, Andorra, and Turkey.

4.5 Japanese Radio Law Compliance

This device is granted pursuant to the Japanese Radio Law (電波法).

This device should not be modified (otherwise the granted designation number will become invalid).

The following models are qualified for the Japanese market:

MIC ID: [R]202-DGJ063

Since the printable area on the PAN1781 is too small to show the MIC logo and the MIC ID, this information is placed on the package and in the user information.

The package label shows the Giteki mark and the Radio Law sign with the MIC ID as depicted below:

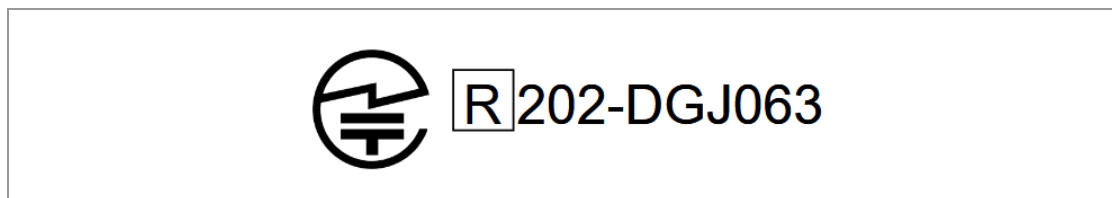

Any product with the PAN1781 integrated and to be sold on the Japanese market has to display the following statement on the product label:

End product Labelling Example



4.6 China (Label Requirements)

The PAN1781 has a Modular CMIIT certification.



The OEM must ensure that SRRC labelling requirements are met. This includes a clearly visible label on the outside of the OEM enclosure specifying the appropriate Panasonic SRRC identifier for this module.

The final Bluetooth product must be marked with an approval code, known as the “China MII ID”, product name, model number, and battery information, place of production, manufacturer name, and CMIIT number.

本设备包含型号核准代码为：CMIIT ID: 2021DJ12938(M) 的无线电发射模块。

Format of the ID is as follows: “**CMIIT ID: 2021DJ12938(M)**”, where:

- **CMIIT**: Abbreviation for China Ministry of Information Industry
- **2021**: Year of application
- **DJ**: Code indicating equipment category
- **12938(M)**: Approval serial number issued by SRRC

End product Labelling Example:

本设备包含型号核准代码为：CMIIT ID: 2021DJ12938(M) 的无线电发射模块。

4.7 Korea (Label Requirements)

Since the printable area on the PAN1781 is too small to show the KC logo and ID, this information is placed on the package and in the user information.



The OEM must ensure KC marking requirements. The integrator of the module should refer to the labeling requirements for Korea available on the Korea Communications Commission (KCC) website.

The module is not labeled with its own KC mark. The final product requires the KC mark and MSIP certificate number of the module.

Format of the ID is as follows: “**MSIP: R-R-Pid-PAN1781**”, where

- **MSIP:** Ministry of Science, ICT & Future Planning
- **R:** Indication of Broadcasting Communication Equipment code
- **R:** Indication of Basic Registration Information
- **Pid:** Indication of Application Information
- **PAN1781:** Indication of Product

End Product Labelling Example:



The label of end product should indicate the RF approved module's certification number as well as the end-device's certification number.

For more details please visit:

Korea Communications Commission (KCC)

<http://www.kcc.go.kr>

National Radio Research Agency (RRA)

<http://rra.go.kr>

4.8 Australia and New Zealand Conformity according to RCM

This Suppliers Declaration of Conformity (SDoC) is also valid for Australia.

4.8.1 Supplier's Details

Name	Microsystem Support Limited
New Zealand (Physical Address)	62 Heathcote Road Castor Bay Auckland 0620
New Zealand (Postal Address)	PO Box 31-372 Milford Auckland 0741
(New Zealand) Company Number/GST Number	256648
Supplier Number	E7689

New Zealand Contact Information

Telephone	+ 64 9 4109286
Mobile	+ 64 27 4928152
Email	mikefoxnz@gmail.com

4.8.2 Conformity According to Section 134 (1) (g) of the New Zealand Radio-communications Act 1989

Product Details

Brand Name	Model	Description
Panasonic	PAN1781	Bluetooth Low Energy Module 2 402 MHz to 2 480 MHz

All modules described in this Product Specification comply with the standards according to the following articles:

3.1a Safety/Health: ETSI EN 62368-1: 2014/AC: 2015/A11: 2017/AC:2017
ETSI EN 62479:2010

3.1b EMC: ETSI EN 301 489-1 V2.2.3
ETSI EN 301 489-17 V3.2.4

3.2 Radio: AS/NZS 4268:2017
ETSI EN 300 328 V2.2.2

4.9 Bluetooth

For Bluetooth end products which integrate the PAN1781 the OEM needs to apply for an own end product listing (EPL) at the Bluetooth SIG. If the PAN1781 is used on more than one OEM product, costs can be saved by applying for a family EPL.

For the end product EPL the following IDs can be used in order to avoid re-testing:

Bluetooth 5.1	Declaration ID	QDID
Component (Tested) Link Layer	D043345	136204
Component (Tested) Host Layer	D043346	136227
Component (Tested) RF PHY	D043344	137461
End Product (PAN1781 Bluetooth LE LR Module)	D054152	164160

Bluetooth Marks

According to the Bluetooth SIG, the PAN1781 fulfills the criteria to label your product as a Bluetooth device:



For further information please refer to the Bluetooth website www.bluetooth.com

5 Contact Details

5.1 Contact Us

Please contact your local Panasonic Sales office for details on additional product options and services:

For Panasonic Sales assistance in the **EU**, visit

<https://eu.industrial.panasonic.com/about-us/contact-us>

Email: wireless@eu.panasonic.com

For Panasonic Sales assistance in **North America**, visit the Panasonic website “Sales & Support” to find assistance near you at

<https://na.industrial.panasonic.com/distributors>

Please visit the **Panasonic Wireless Technical Forum** to submit a question at

<https://forum.na.industrial.panasonic.com>

5.2 Product Information

Please refer to the Panasonic Wireless Connectivity website for further information on our products and related documents:

For complete Panasonic product details in the **EU**, visit

<http://pideu.panasonic.de/products/wireless-modules.html>

For complete Panasonic product details in **North America**, visit

<http://www.panasonic.com/rfmodules>