

PAN9026

Wi-Fi Dual Band 2.4/5 GHz and Bluetooth Module Design Guide

Rev. 1.1



Overview

The PAN9026 is a 2.4/5 GHz ISM band Wi-Fi and Bluetooth radio module, which includes a wireless radio for easy integration of Wi-Fi and Bluetooth connectivity into various electronic devices.

Features

- Dual band 2.4/5 GHz 802.11 a/b/g/n Wi-Fi/BT combo module
- Supports 802.11i security standards through AES, CCMP, and more security mechanisms
- 802.11e Quality of Service is supported for multimedia applications
- IEEE 802.11n-compliant, 1x1 spatial stream with data rates up to MCS7 150 Mbps
- Bluetooth 5.0 (includes LE)
- Dual simultaneous and independent WLAN and Bluetooth operation
- Dynamic Rapid Channel Switching (DRCS) for simultaneous operation in 2.4 GHz and 5 GHz bands
- Indoor Location and Navigation with IEEE 802.11mc

- Power management with sleep clock
- Coexistence interface for arbitration of co-located WLAN, Bluetooth, or Mobile Wireless System (e.g. LTE)
- Generic interfaces include SDIO 3.0 and high-speed UART for host processor connection
- Software Linux driver

Characteristics

- Surface Mount Type (SMT)
17.5 mm x 10.0 mm x 2.6 mm
- Marvell® 88W8977 WLAN 2.4/5 GHz and Bluetooth single-chip solution inside
- TX Power +16 dBm @ 802.11b
- RX Sensitivity -98 dBm @ 802.11b DSSS 1 Mbps
- IEEE 802.11n 20 MHz and 40 MHz channel bandwidth
- Long and Short Guard Interval support
- Power supply 3.3 V, 2.2 V, 1.8 V
- Current consumption Wi-Fi typical 400 mA @ TX and 70 mA @ RX
- SDIO 1-bit or 4-bit
- Wide temperature range of -30 to +85 °C

Block Diagram

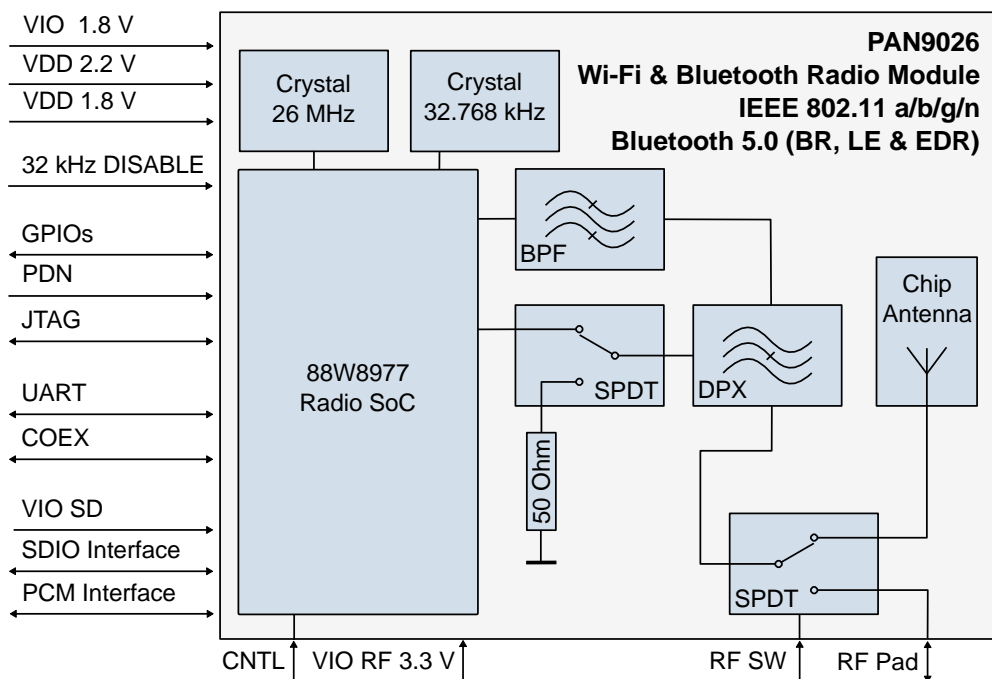

By purchase of any of the products described in this document the customer accepts the document's validity and declares their agreement and understanding of its contents and recommendations. Panasonic Industrial Devices Europe GmbH (Panasonic) reserves the right to make changes as required at any time without notification. Please consult the most recently issued Design Guide before initiating or completing a design.

© Panasonic Industrial Devices Europe GmbH 2017.

This specification sheet is copyrighted. Reproduction of this document is permissible only if reproduction is without alteration and is accompanied by all associated warranties, conditions, limitations, and notices. Do not disclose it to a third party.

All rights reserved.

This Design Guide does not lodge the claim to be complete and free of mistakes.

Engineering Samples (ES)

If Engineering Samples are delivered to the customer, these samples have the status "Engineering Samples". This means that the design of this product is not yet concluded. Engineering Samples may be partially or fully functional, and they may differ from the published Product Specification.

Engineering Samples are not qualified and they are not to be used for reliability testing or series production.

Disclaimer

The customer acknowledges that samples may deviate from the Design Guide and may bear defects due to their status of development and the lack of qualification mentioned above.

Panasonic rejects any liability or product warranty for Engineering Samples. In particular, Panasonic disclaims liability for damages caused by:

- The use of the Engineering Sample other than for evaluation purposes, particularly the installation or integration in another product to be sold by the customer,
- Deviation or lapse in function of the Engineering Sample,
- Improper use of the Engineering Sample.

Panasonic Industrial Devices Europe GmbH disclaims any liability for consequential and incidental damages. In case of any queries regarding the Engineering Samples, please contact your local sales partner or the related product manager.

Table of Contents

1	About This Document	5
1.1	Purpose and Audience	5
1.2	Revision History.....	5
1.3	Use of Symbols	5
1.4	Related Documents	5
2	Overview	6
3	PAN9026 Module	7
3.1	Block Diagram	7
3.2	Footprint	8
3.3	Land Pattern	8
3.4	Solder Mask.....	9
3.5	Placement.....	10
3.6	Power Supply	12
3.7	RF Path	14
4	PAN9026 SDIO Adapter	16
4.1	Live View	16
4.2	Functional Blocks	17
4.3	Part Placement	18
4.4	Schematic.....	19
4.5	PCB Layout	20
5	PAN9026 MicroSD Adapter	24
5.1	Live View	24
5.2	Functional Blocks	25
5.3	Part Placement	26
5.4	Schematic.....	27
5.5	PCB Layout	28
6	Cautions	32
6.1	Restricted Use	32
7	Appendix	33
7.1	Ordering Information.....	33
7.2	Contact Details	34

1 About This Document



1.1 Purpose and Audience

This Design Guide provides details on the electrical integration of the Panasonic PAN9026 module. It is intended for hardware design, application, and Original Equipment Manufacturers (OEM) engineers. The product is referred to as “the PAN9026” or “the module” within this document.

1.2 Revision History

Revision	Date	Modifications/Remarks
1.0	18.12.2017	First design guide version.
1.1	03.07.2018	Add section: ⇒ 5 PAN9026 MicroSD Adapter , 5.1 Live View , 5.2 Functional Blocks , 5.3 Part Placement , 5.4 Schematic , 5.5 PCB Layout Additional models: ⇒ 7.1 Ordering Information

1.3 Use of Symbols

Symbol	Description
	Note Indicates important information for the proper use of the product. Non-observance can lead to errors.
	Attention Indicates important notes that, if not observed, can put the product's functionality at risk.
	Tip Indicates useful information designed to facilitate working with the PAN9026.
⇒ [chapter number] [chapter title]	Cross reference Indicates cross references within the document. Example: Description of the symbols used in this document ⇒ 1.3 Use of Symbols .
✓	Requirement Indicates a requirement that must be met before the corresponding tasks can be completed.

1.4 Related Documents

Please refer to the Panasonic website for related documents ⇒ [7.2.2 Product Information](#).

2 Overview

This Design Guide applies to the PAN9026 WLAN/BT combo module and the PAN9026 SDIO Adapter development platform. The intention is to enable our customers to easily and fast integrate our module PAN9026 in their product. This Design Guide describes the hardware integration and gives useful hints.

This document is structured into three main parts:

- The hardware integration of the PAN9026 module.
- The PAN9026 SDIO Adapter as an example for the module integration.
- The PAN9026 MicroSD Adapter as an example for the module integration.

Please refer to the Panasonic website for related documents ⇒ [7.2.2 Product Information](#).

Further information on the variants and versions ⇒ [7.1 Ordering Information](#).

3 PAN9026 Module

3.1 Block Diagram

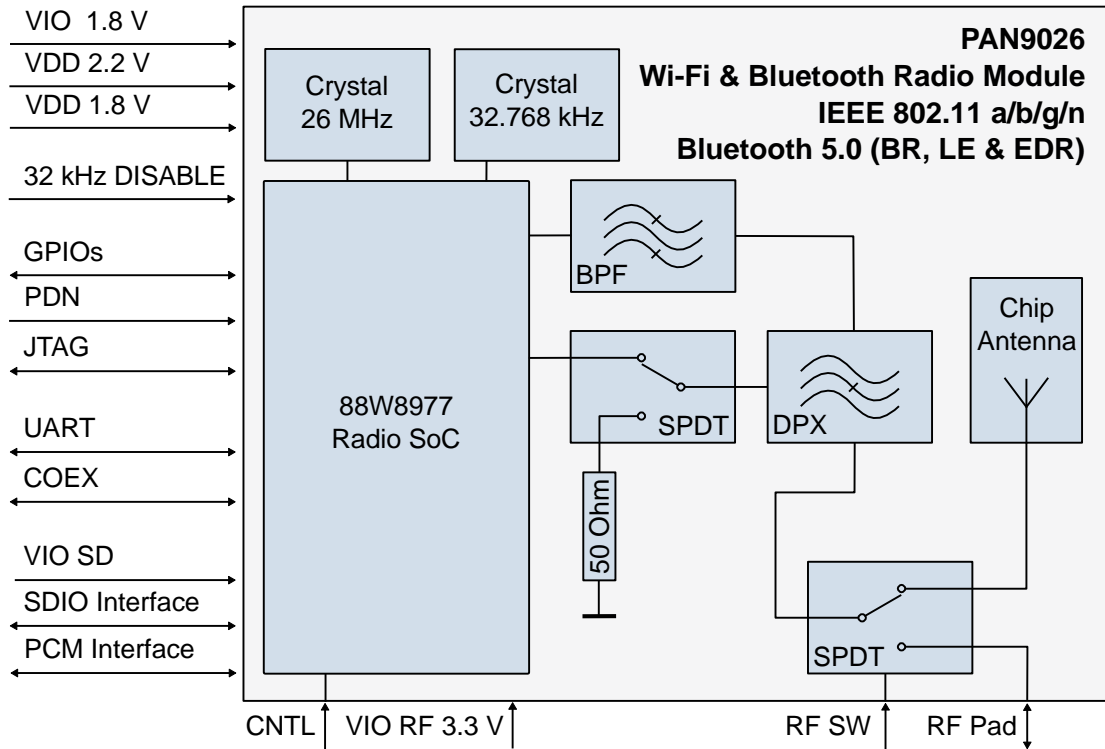

3.2 Footprint

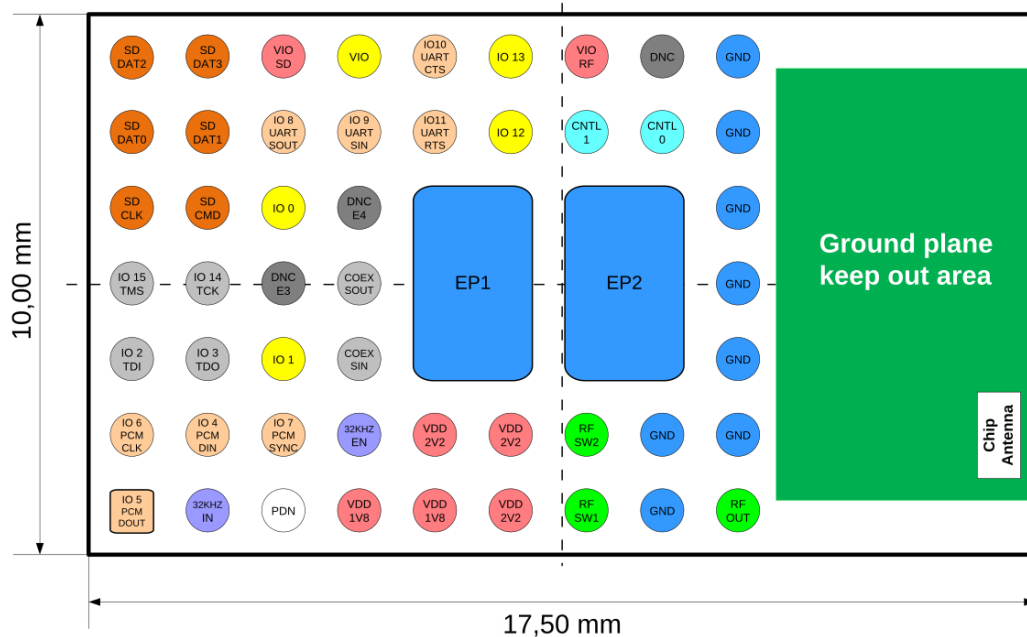

Top View

3.3 Land Pattern

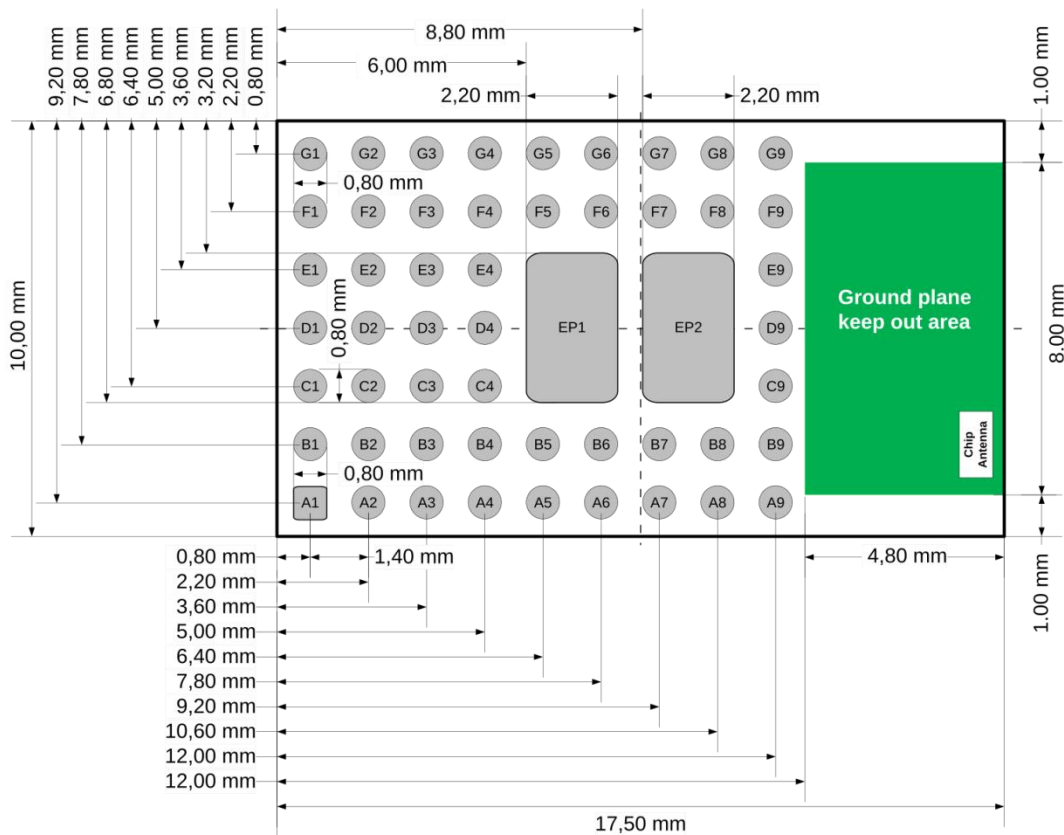

Top View

3.4 Solder Mask

It is recommended to use the first layout (⇒ [Variant 1](#)) for the soldering mask layout to reduce voids on the thermal pads. Use the following dimensions:

- ✓ The Resist Mask should be 50 µm bigger than the pad size (⇒ [3.3 Land Pattern](#)).
- ✓ The Solder Mask apertures should have the diameter as the pads (⇒ [3.3 Land Pattern](#)); they are separated in two semi circles with 300 µm distance, and a shifting about 150 µm.

Variant 1

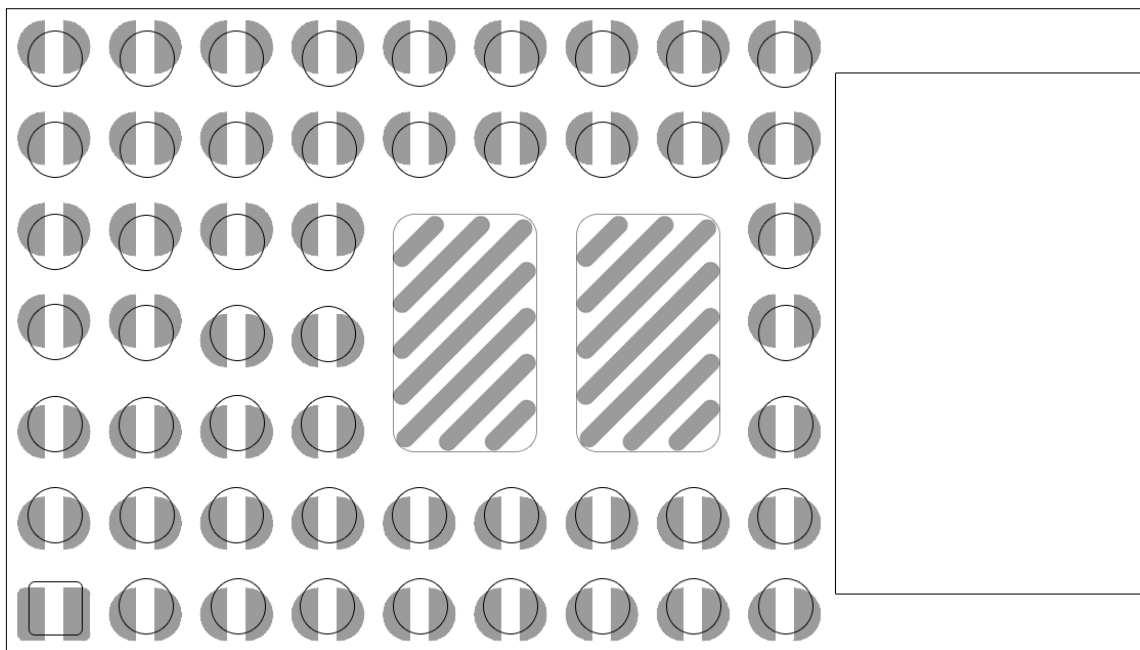

Variant 2

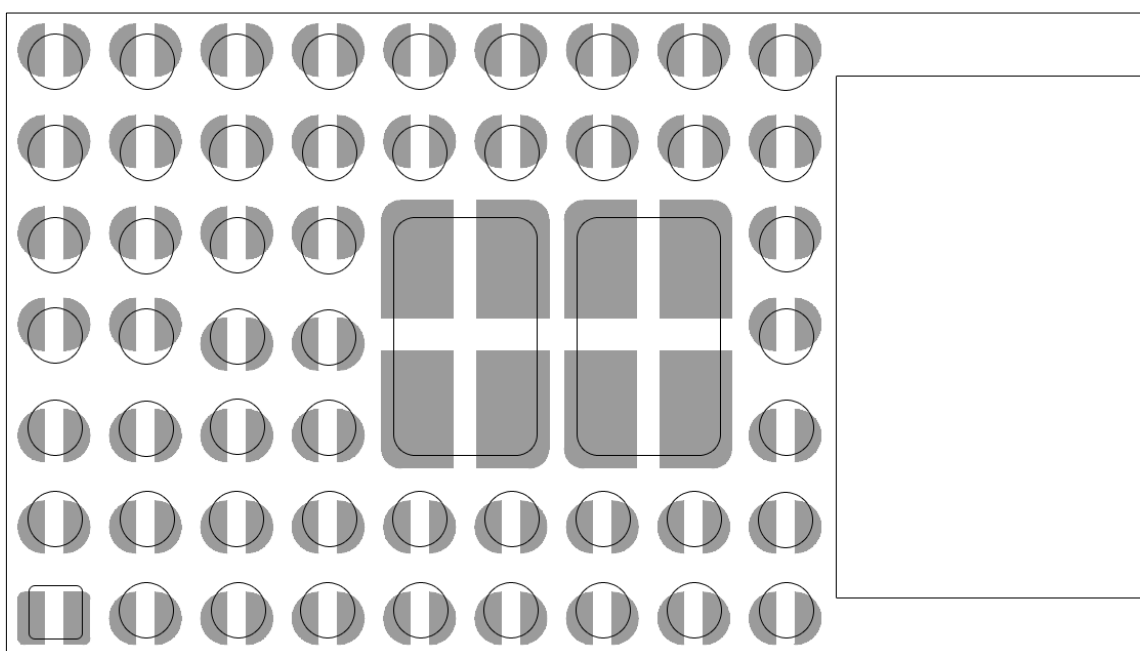

3.5 Placement



Antenna Keep-out Area

Do not place any ground plane under the marked restricted antenna area in any layer! This would be affecting the performance of the chip antenna in a critical manner.

Further information ⇒ [Antenna Keep-out Area](#).

The following conditions must be met:

- ✓ Keep this product away from heat. Heat is the major cause of decreasing the life of these products.
- ✓ Keep this product away from other high frequency circuits.

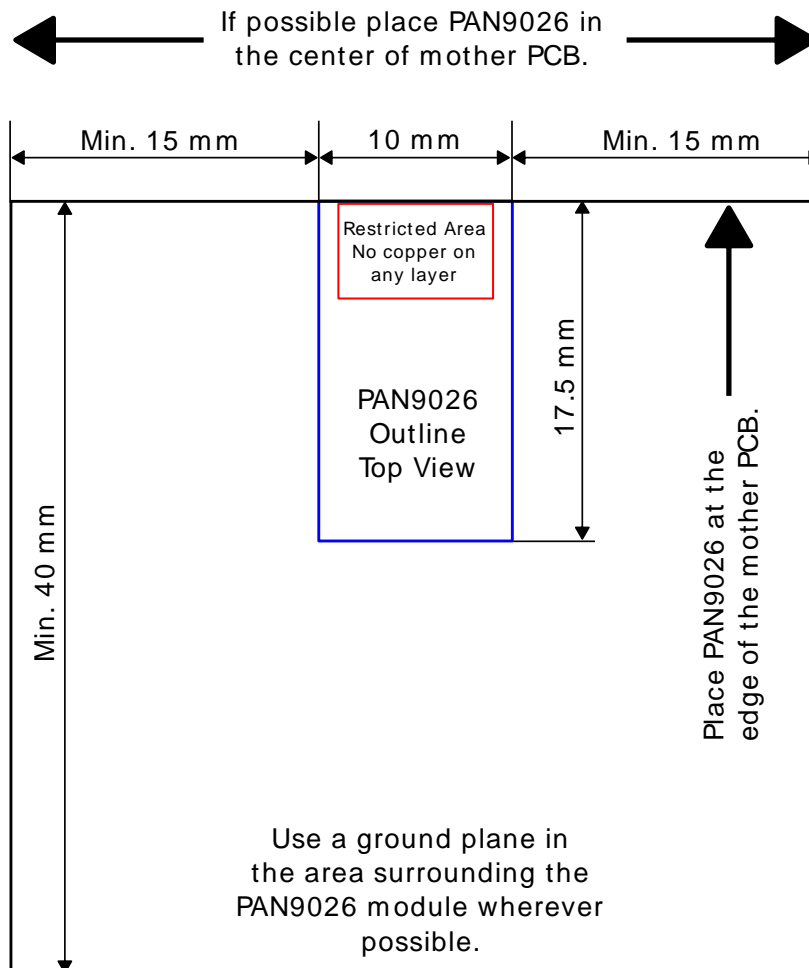

Dimensions are in mm.

Note: The above recommendation for the ground plane is based on a FR4 4-Layer PCB.

Antenna Keep-out Area

The use of the internal module antenna requires a cutout area of 8.0 mm x 4.8 mm under the PAN9026 module. This keep-out area shall be located in any layer under the module antenna keep-out area.

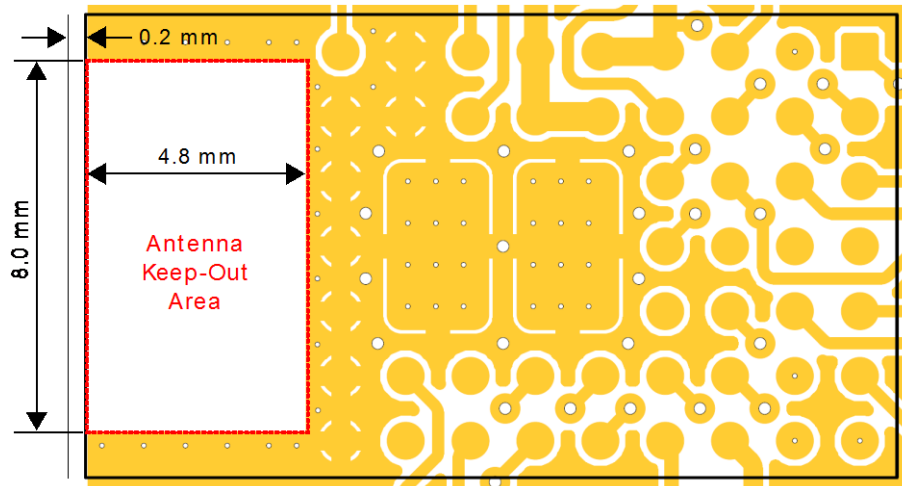

Note exemplify the keep-out area in all layers of the PAN9026 SDIO Adapter: ⇒ [Top Layer](#), ⇒ [Layer 2](#), ⇒ [Layer 3](#) and ⇒ [Bottom Layer](#).

For the use of an external antenna refer to section ⇒ [3.7.1 External Antenna](#).

Impact of Placement on the Antenna Radiation Pattern



The placement of the module, the surrounding material, and the customer components might have an impact on the radiation pattern of the on-board antenna.

It is recommended to verify the perfect position of the module in the target application before fixing the design. In some applications it could be reasonable to use an external antenna to handle application caused placement restrictions.

For the use of an external antenna refer to section ⇒ [3.7.1 External Antenna](#).

3.6 Power Supply

The following conditions must be met:

- ✓ The supply voltage must be free of AC ripple voltage (for example from a battery or a low noise regulator output). For noisy supply voltages, provide a decoupling circuit (for example a ferrite in series connection and a bypass capacitor to ground of at least 47 μ F directly at the module).
- ✓ The supply voltage should not be exceedingly high or reversed. It should not carry noise and/or spikes.
- ✓ Make sure that the power-up sequence meets the requirements mentioned in the PAN9026 Product Specification.
- ✓ The supply current of VDD 1.8 V and VDD 2.2 V must be limited to maximal 1 A.



Leakage Optimization

The PAN9026 can be put into low-leakage mode of operation for applications not using Wi-Fi and Bluetooth. There are two possibilities:

- The power-down state provides the lowest leakage mode of operation. Assert the PDn pin low to enter the power-down mode.
- Power off all power rails. In this case, the state of the PDn pin is irrelevant.

Power Configuration Example with 3.3 V Host Operation and 1.8 V VIO

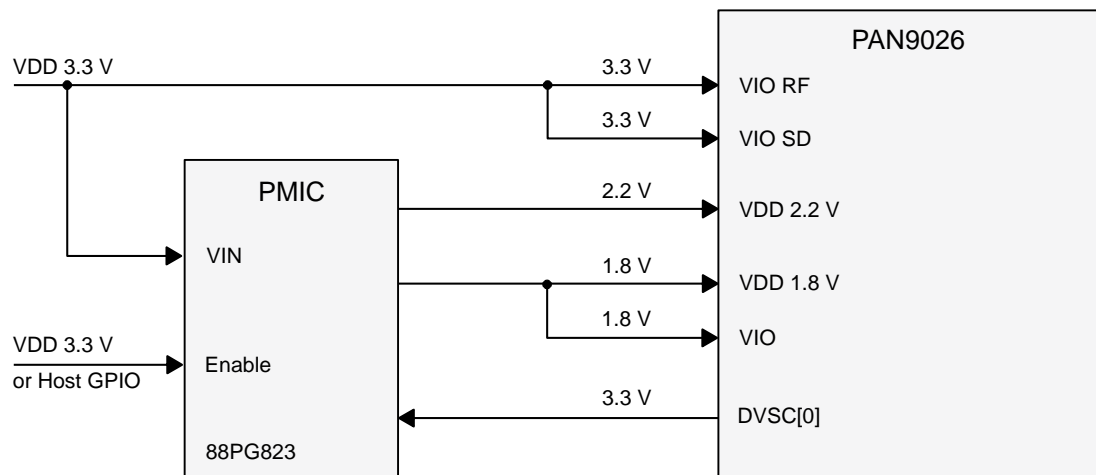

This configuration with a Marvell® 88PG823 Power Management IC is used in the PAN9026 SDIO Adapter ⇒ [4 PAN9026 SDIO Adapter](#).

Power Configuration Example with 3.3 V Host Operation and 3.3 V VIO



GPIOs with 3.3 V Level

It is possible to connect the VIO pin to VDD 3.3 V, to enable the 3.3 V operation of the GPIOs. In this case, it is not possible to use the internal 32.768 kHz crystal oscillator for low power modes. Connect the 32KHZ_EN pin via a 100 Ω resistor to ground to disable the internal 32.768 kHz crystal oscillator. The low power modes will then use the reference clock, which has lower accuracy. This is not recommended for the IEEE 802.11 power save mode.

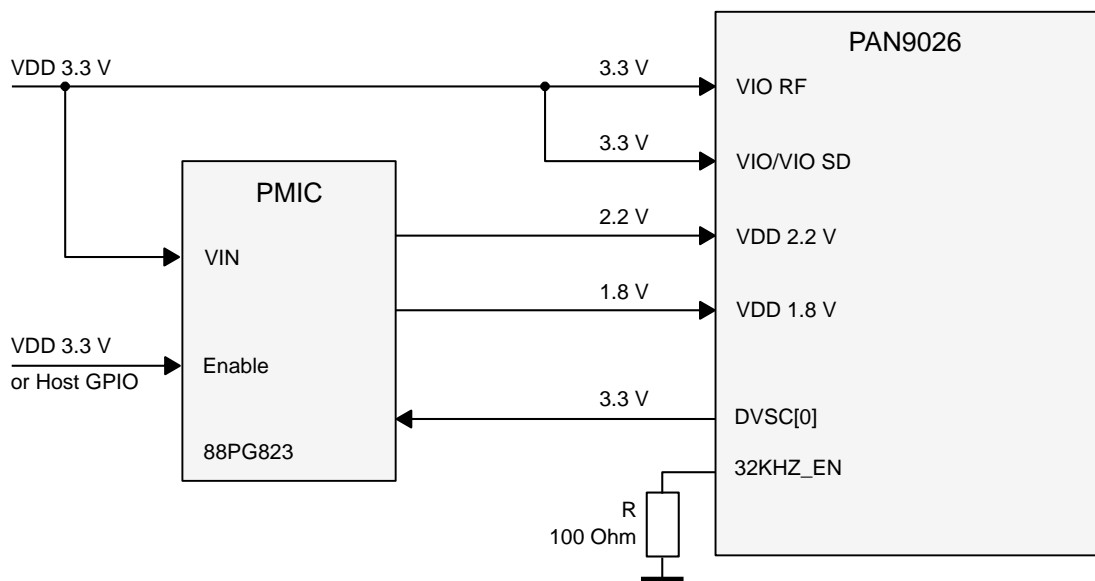

Power Configuration Example with 1.8 V Host Operation

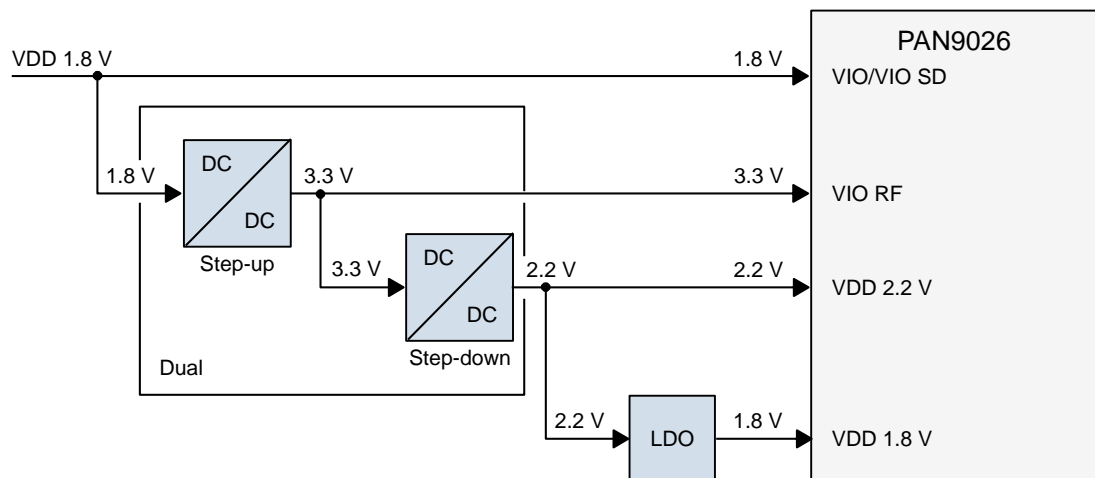



Power-up Sequence

The power-up sequence must meet the requirements mentioned in the chapter Power-up Sequence in the PAN9026 Product Specification.

3.7 RF Path

3.7.1 External Antenna



Antenna Warning

The PAN9026 is tested with a standard U.FL connector and with the antenna listed in the regulatory and certification chapter of the PAN9026 Product Specification. When integrated into the OEM's product, these fixed antennas require installation preventing end users from replacing them with non-approved antennas. Any antenna not in the regulatory and certification chapter of the PAN9026 Product Specification must be tested to comply with FCC Section 15.203 for unique antenna connectors and with Section 15.247 for emissions.

The PAN9026 module has a 50 Ω RF pin (SMD pad). Connect an external antenna directly or via a connector (e.g. U.FL) with RF trace to this RF pin. This RF trace shall be matched to 50 Ω ⇒ [3.7.2 RF Trace](#).

3.7.2 RF Trace

Ensure that the RF trace impedance is nearly 50 Ω . It is recommended to use a Coplanar Waveguide with Ground (CPWG) design. The impedance is related to the trace width, the distances of the trace to the ground layers and the material of the PCB.

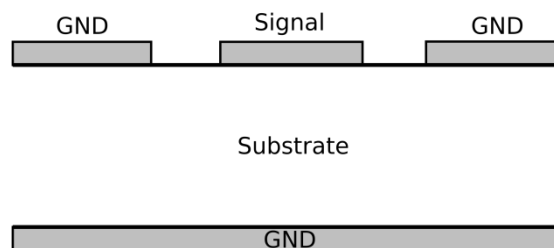

The following design recommendation shall be met:

- ✓ Trace impedance of 50 Ω
- ✓ Trace length shall not exceed 2 cm
- ✓ Via fence around the trace
- ✓ Crossing no other lines (power supply, interfaces or clock traces)

Example 1: 50 Ω Coplanar Waveguide with Ground on SDIO Adapter

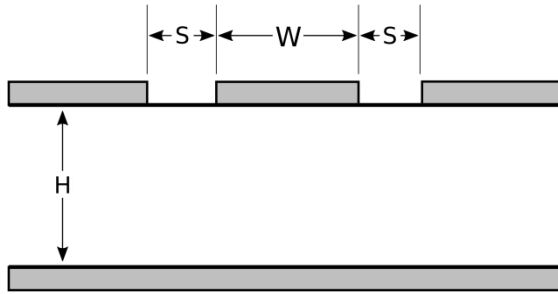

Trace width	$W = 180 \mu\text{m}$
Trace distance to ground	$S = 150 \mu\text{m}$
Substrate thickness	$H = 80 \mu\text{m}$
Effective Permittivity	$\epsilon_r = 3.9$
Loss Tangent	$\tan \delta = 0.015$

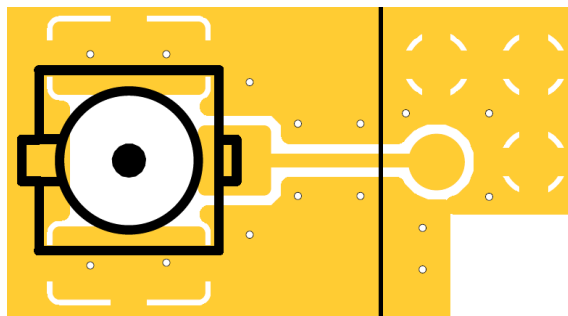

Example 2: 50 Ω Coplanar Waveguide with Ground and Micro Vias

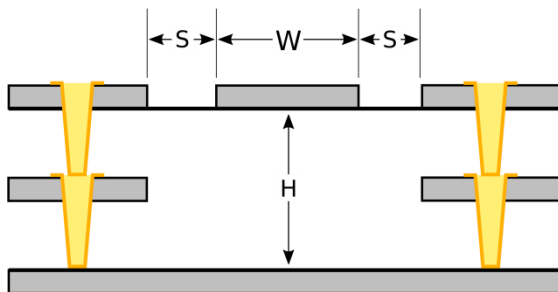

Trace width	$W = 300 \mu\text{m}$
Trace distance to ground	$S = 300 \mu\text{m}$
Substrate thickness	$H = 160 \mu\text{m}$
Effective Permittivity	$\epsilon_r = 4.2$
Loss Tangent	$\tan \delta = 0.006$



4 PAN9026 SDIO Adapter

4.1 Live View

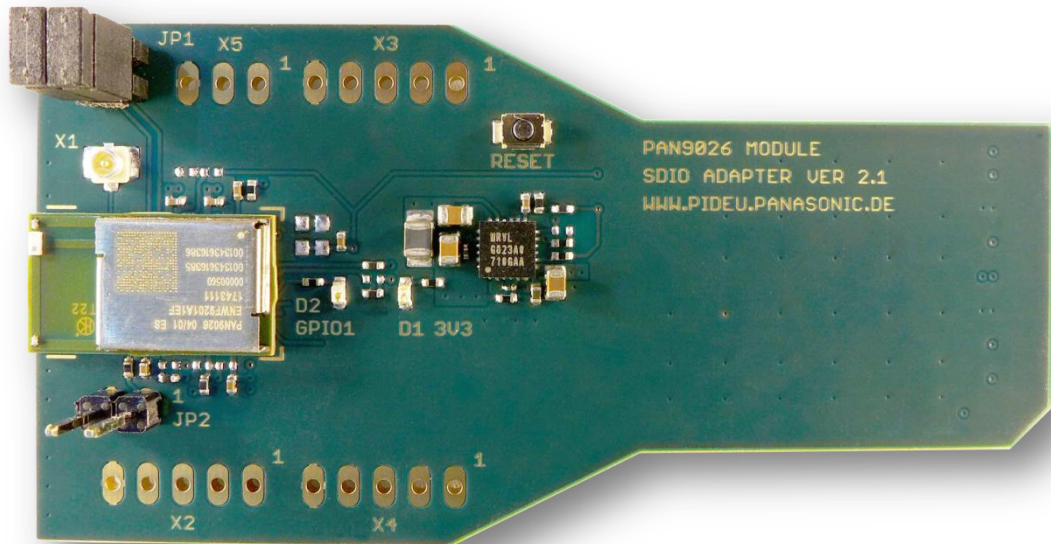

Jumper Configuration

JP1	RF_OUT	
1 - 2 3 - 4	PAN9026 on-board antenna	1 
1 - 3 2 - 4	X1 U.FL connector	1 

JP2	WLAN Interface	Bluetooth Interface	Commentary
1 - 2	SDIO	UART	The configuration is related to the used Linux driver package and its dedicated firmware download.
Open	SDIO	SDIO	

4.2 Functional Blocks

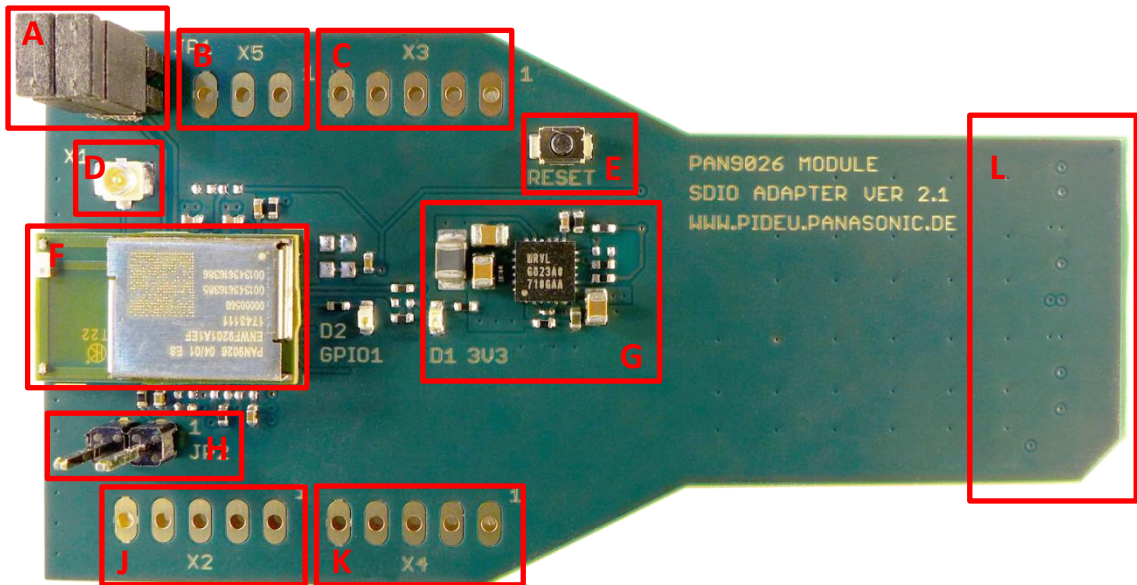
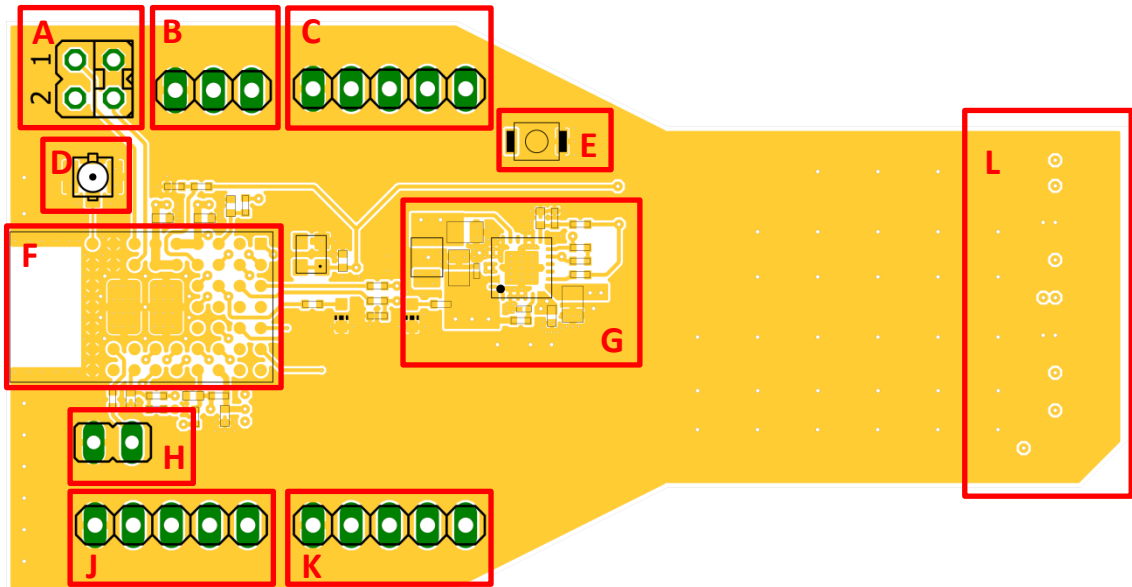

Functional Block	Description	Interface
A	On-board antenna or U.FL connector selection	JP1
B	Coexistence Interface	X5
C	PCM Interface / GPIO[4:7]	X3
D	U.FL connector	X1
E	Reset button	RESET
F	PAN9026 module	
G	Power Management	

Functional Block	Description	Interface
H	WLAN / Bluetooth Interface configuration (CNTL0)	JP2
J	GPIO Interface / GPIO[0:1,12:13]	X2
K	UART HCI Interface / GPIO[8:11]	X4
L	SDIO Interface (VIO SD 3.3V)	

4.3 Part Placement

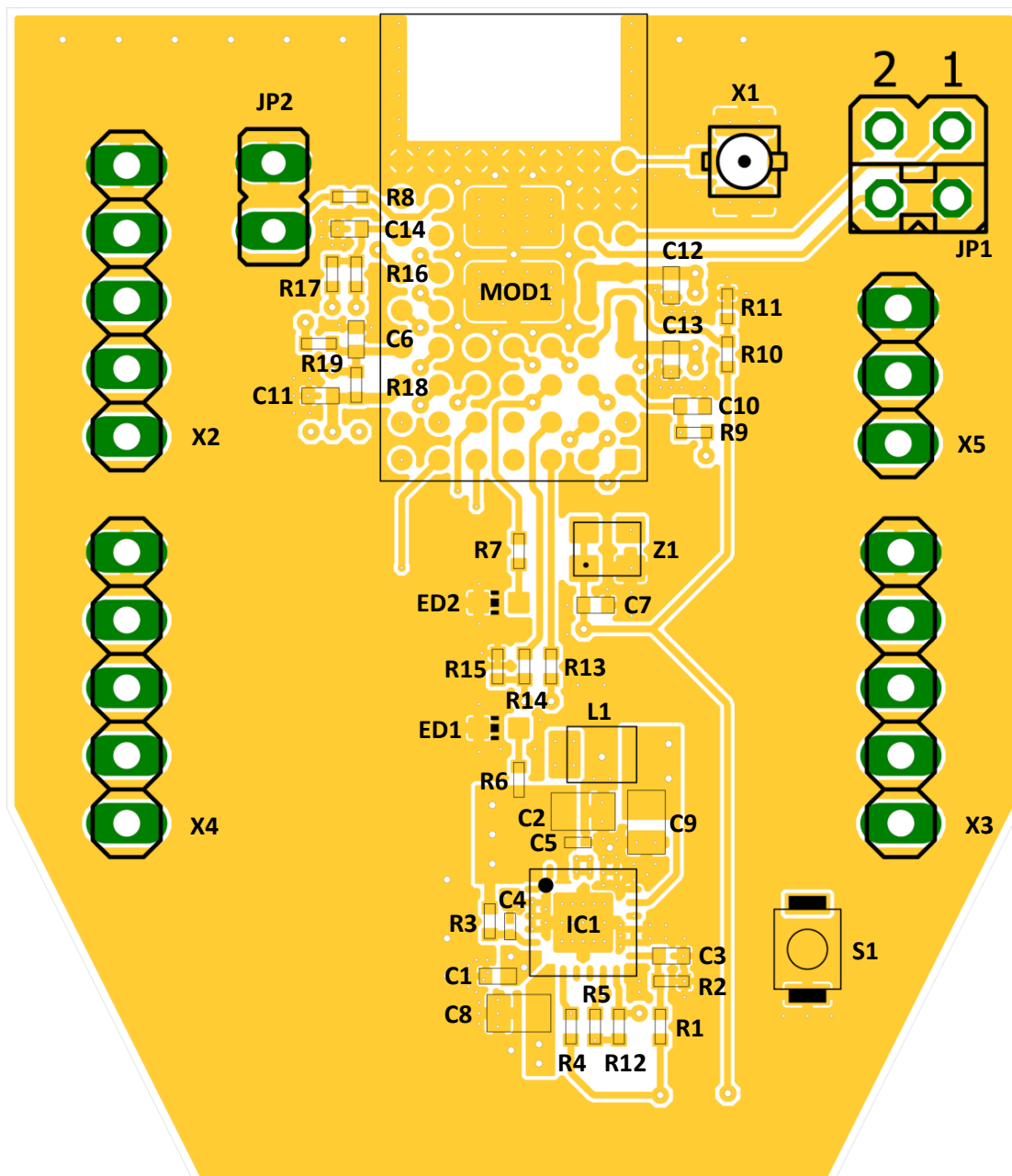

4.4 Schematic

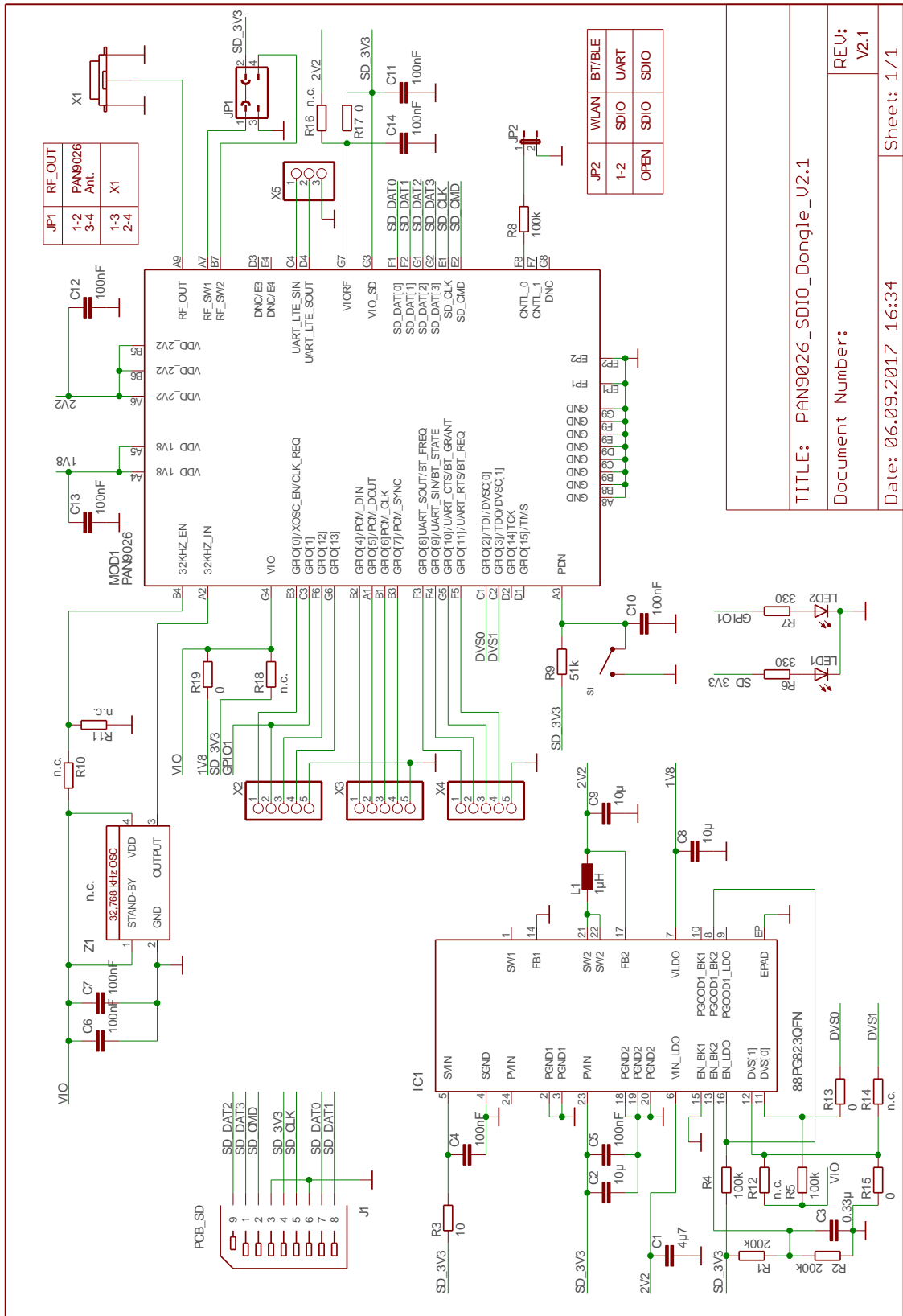

4.5 PCB Layout

4.5.1 Top Layer

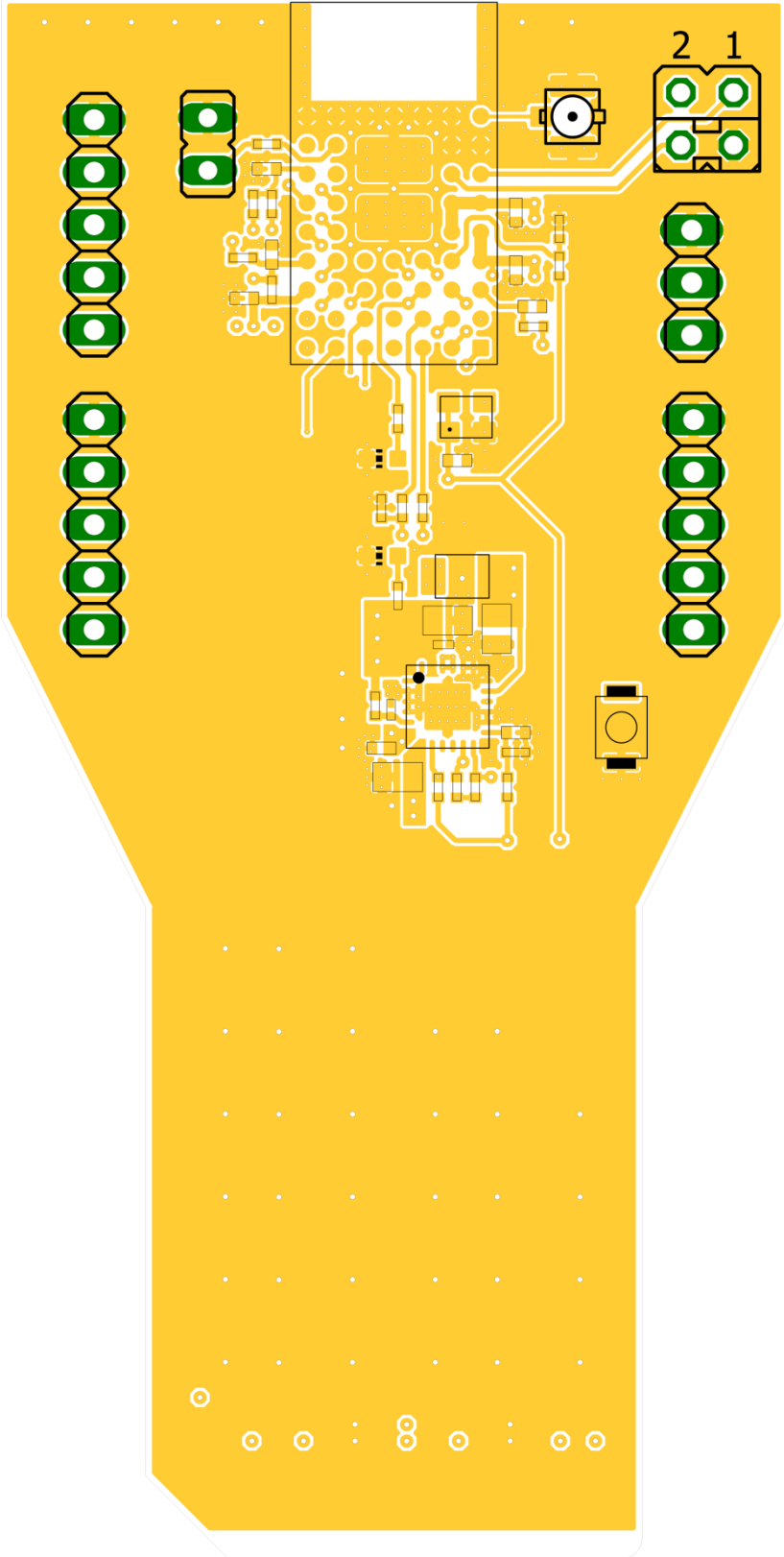

4.5.2 Layer 2

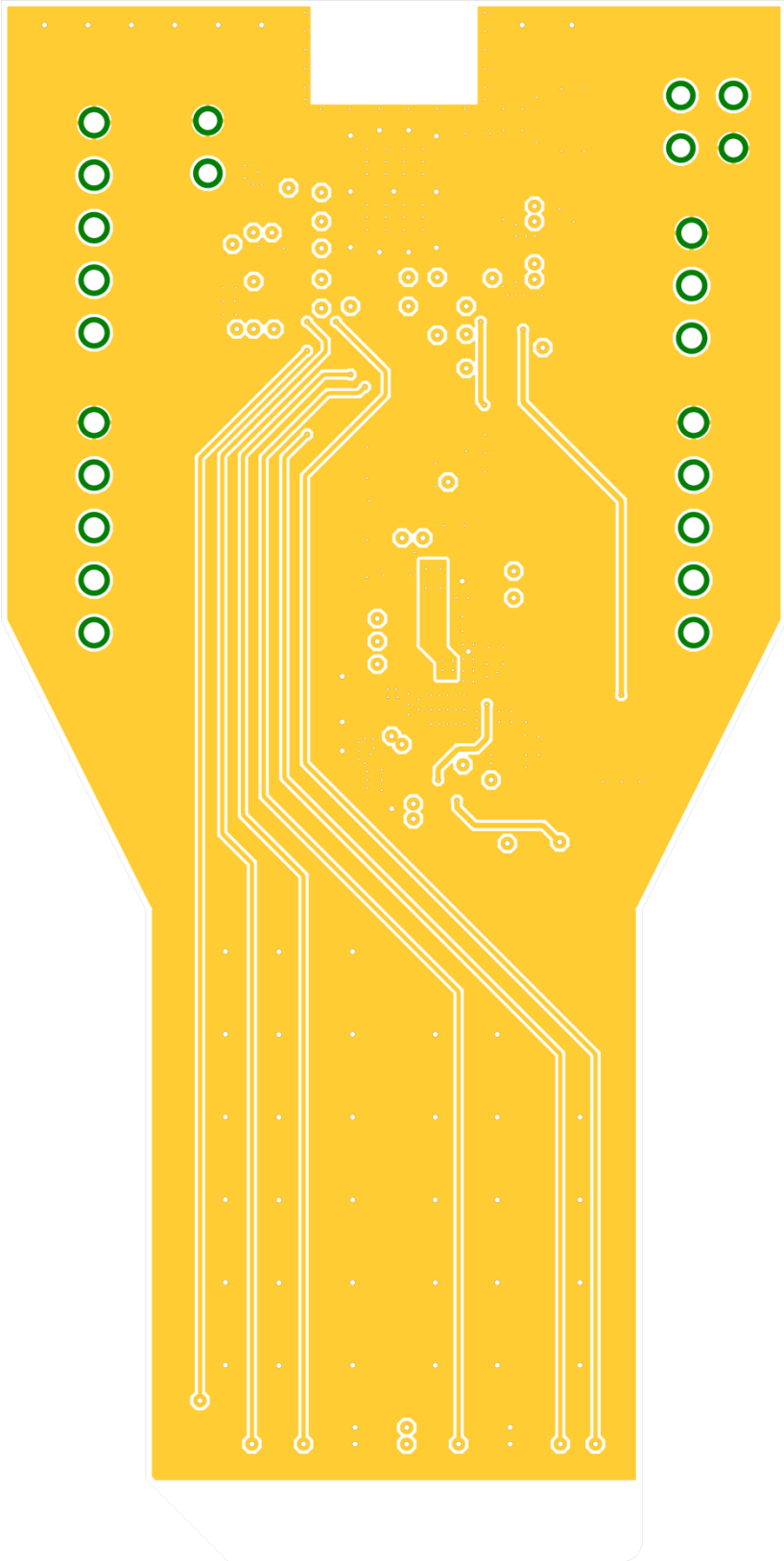

4.5.3 Layer 3

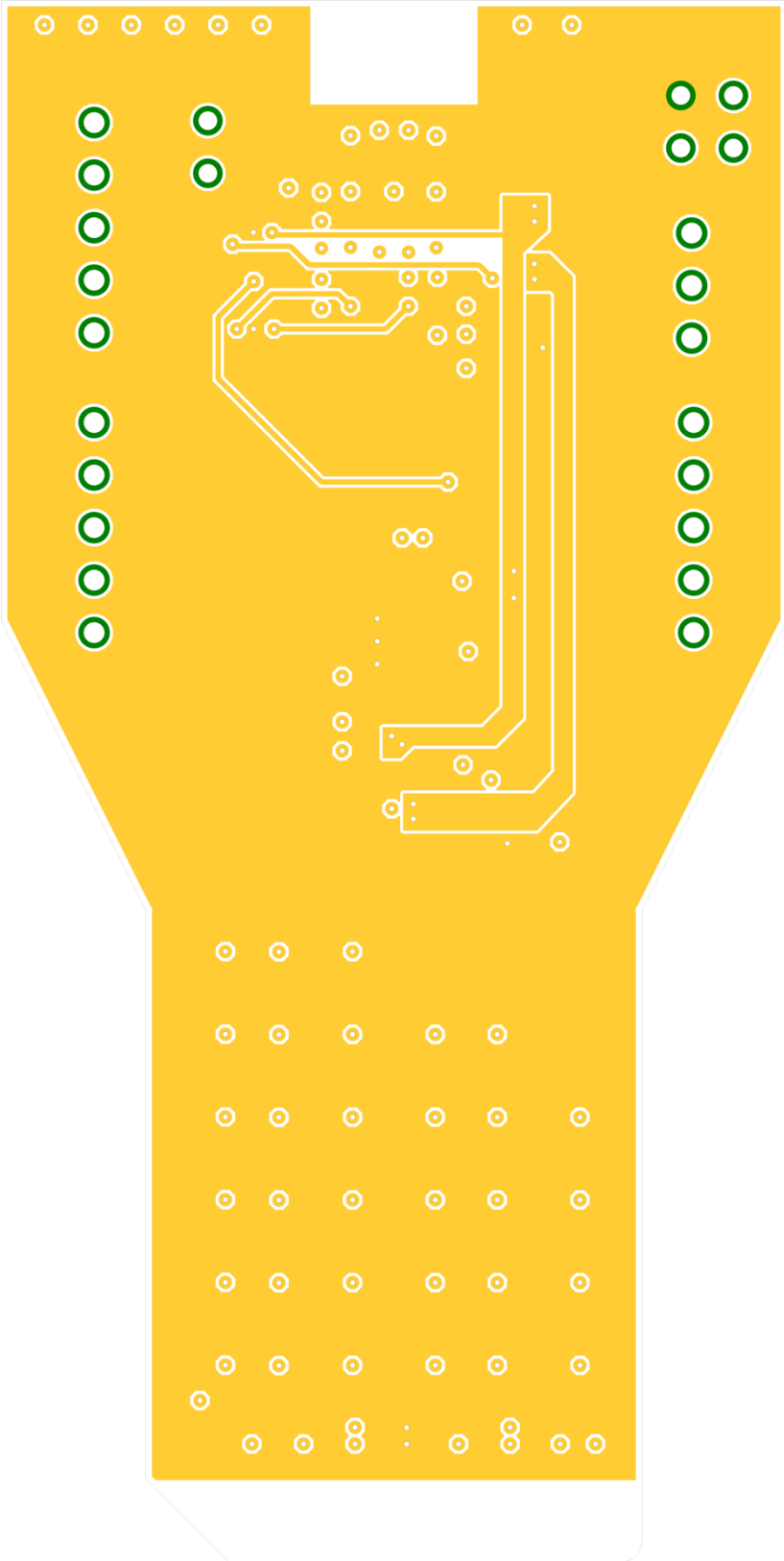

4.5.4 Bottom Layer

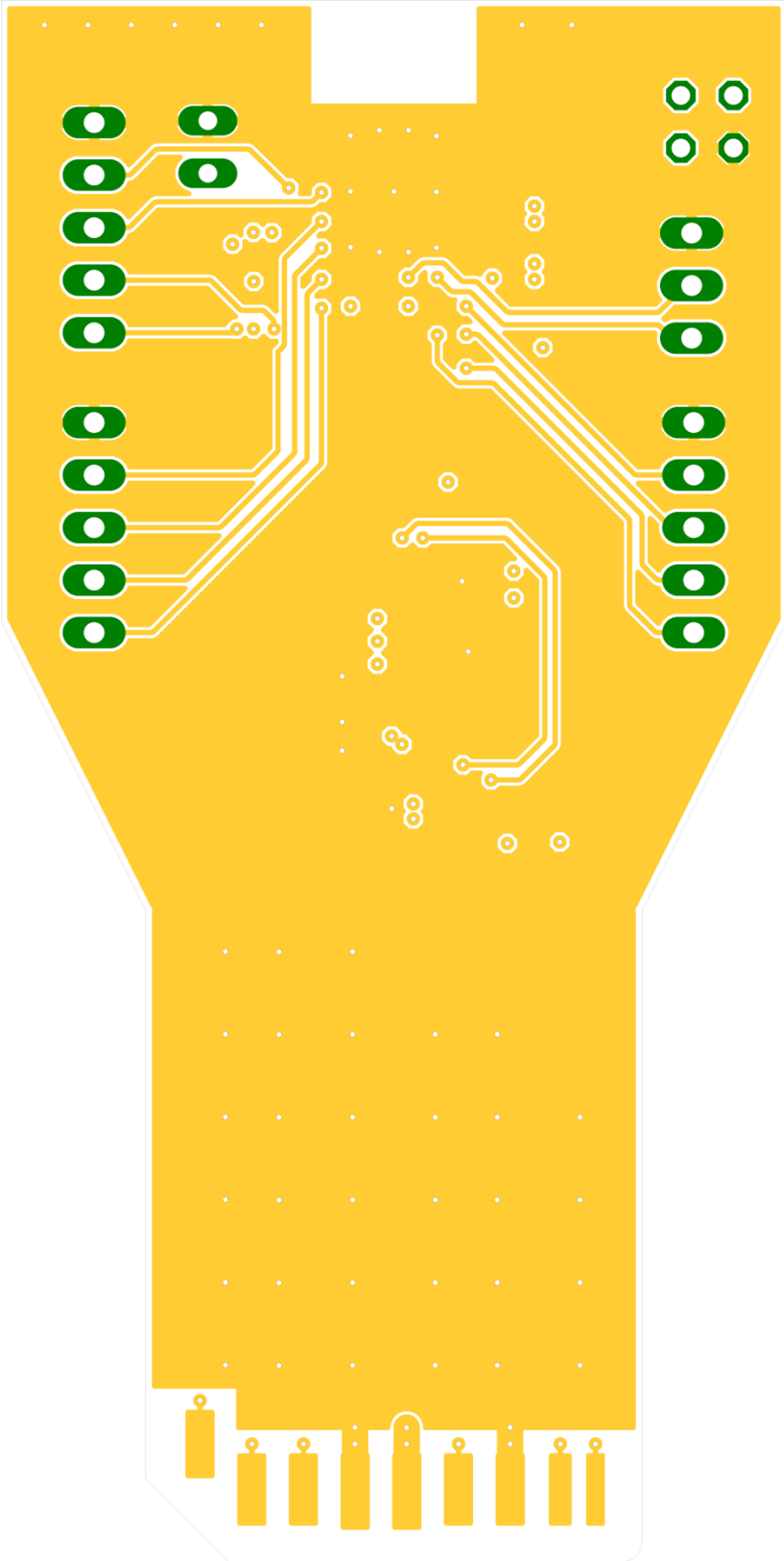

5 PAN9026 MicroSD Adapter

5.1 Live View



Jumper Resistor Configuration

R13	R14	RF_OUT	
open	0 Ω	PAN9026 on-board antenna	Default configuration
0 Ω	open	X1 U.FL connector	Move jumper resistor from position R14 to R13

5.2 Functional Blocks

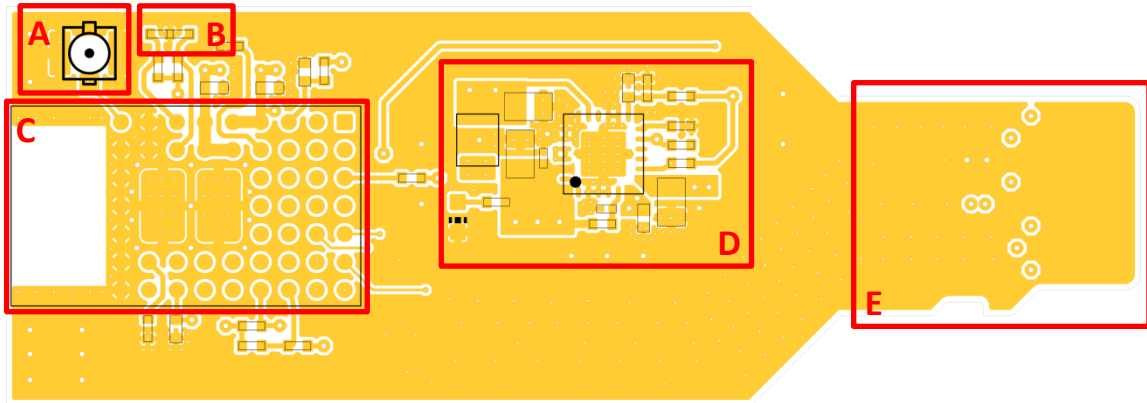

Functional Block	Description	Interface
A	U.FL connector	X1
B	On-board antenna or U.FL connector selection	R13/R14
C	PAN9026 module	
D	Power Management	
E	MicroSD Interface (VIO SD 3.3V)	

5.3 Part Placement

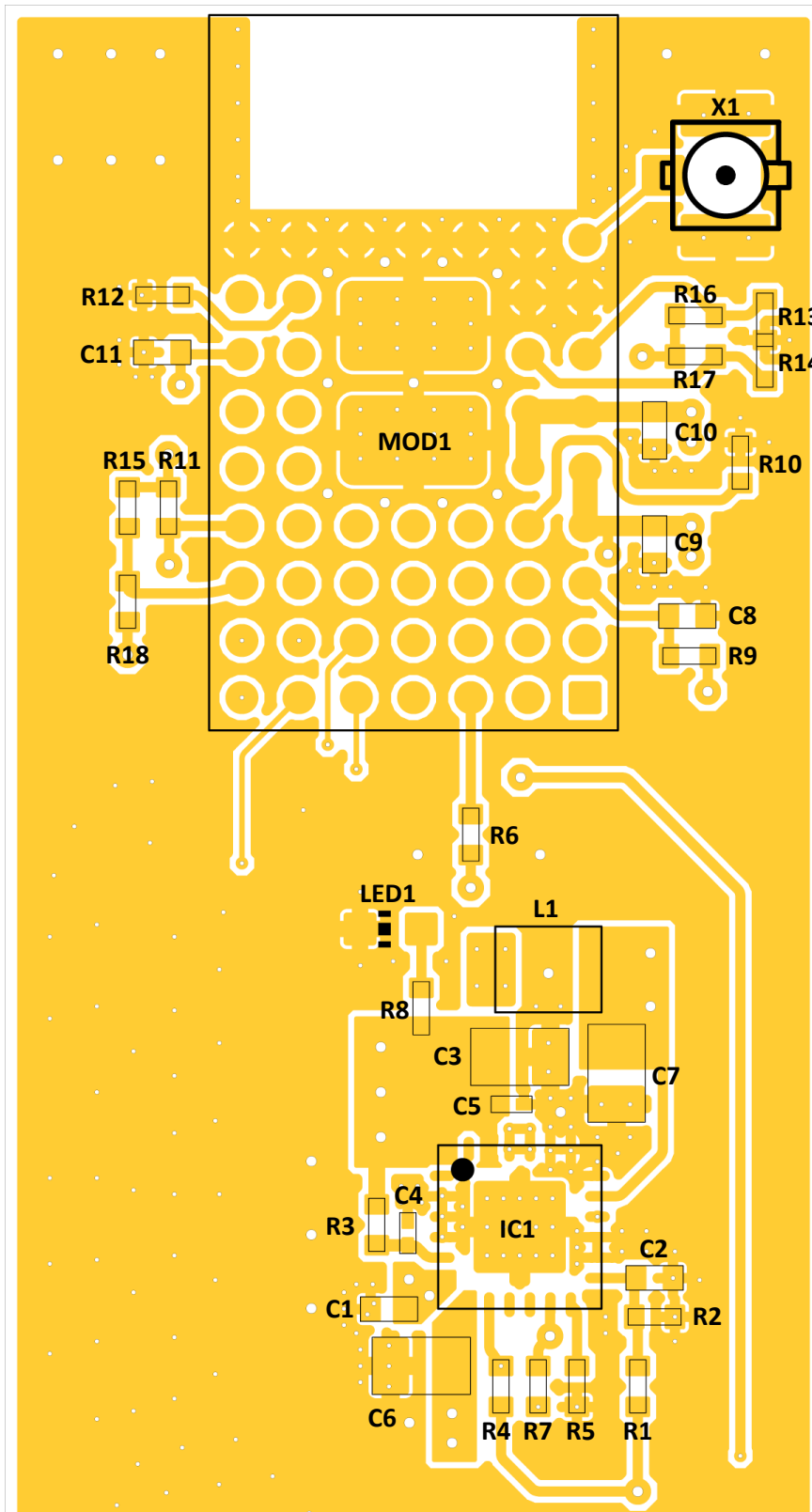

5.4 Schematic

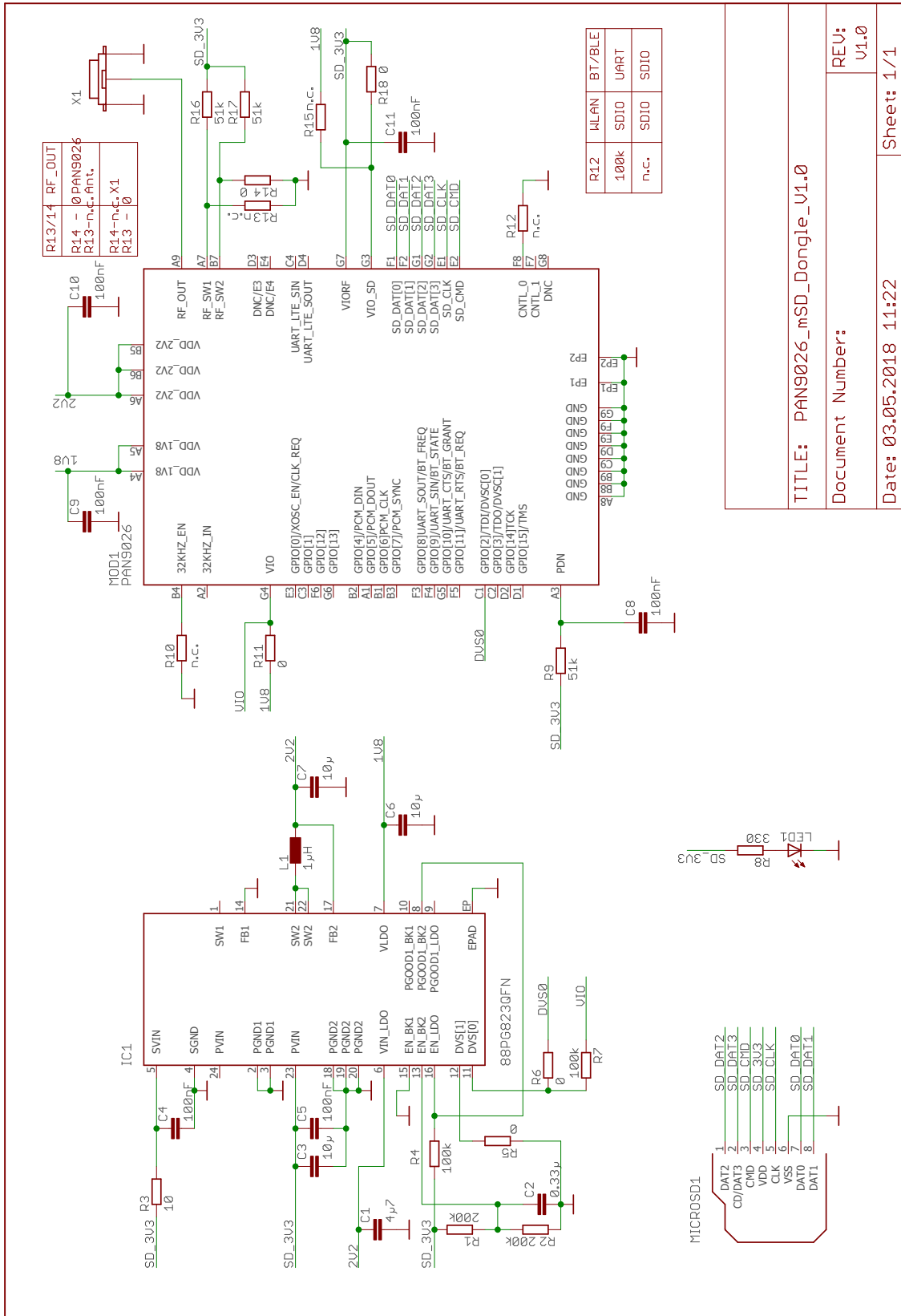

5.5 PCB Layout

5.5.1 Top Layer

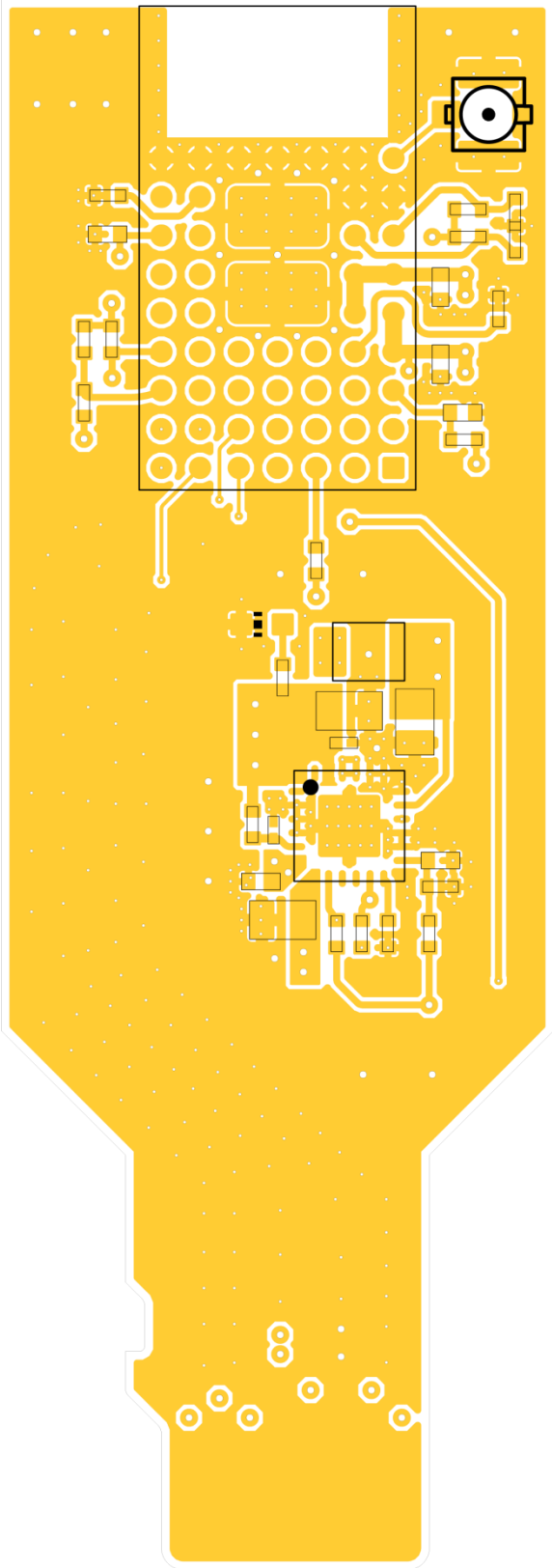

5.5.2 Layer 2

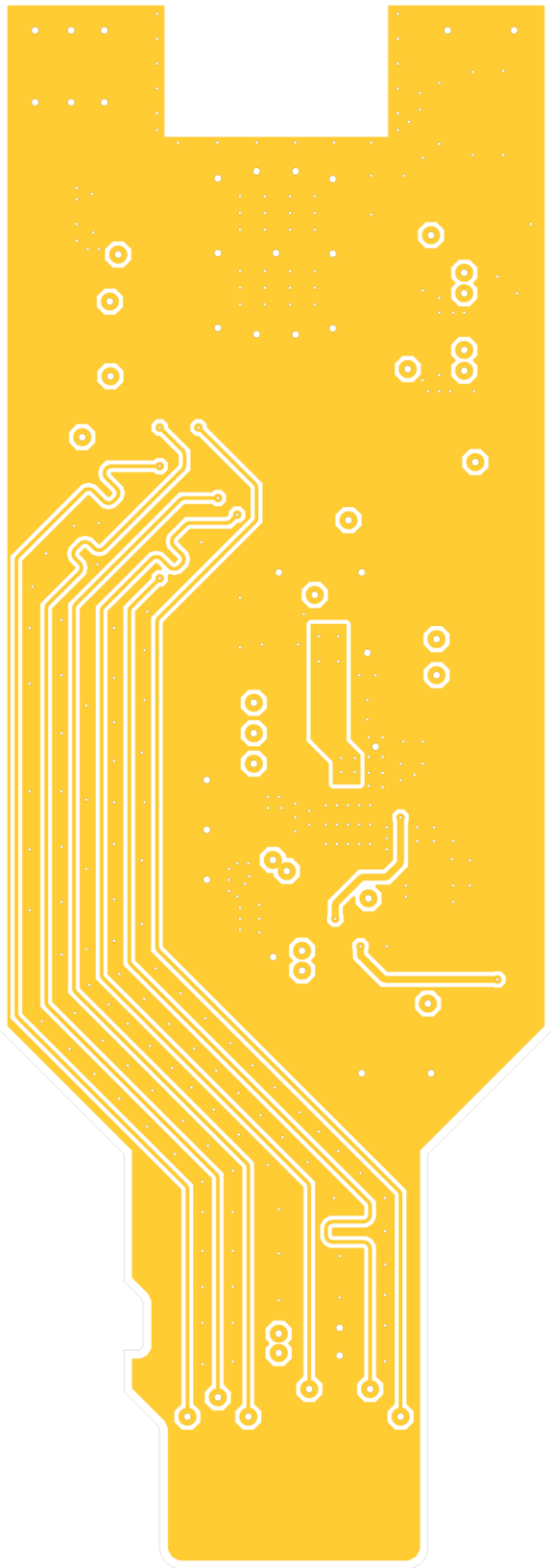

5.5.3 Layer 3

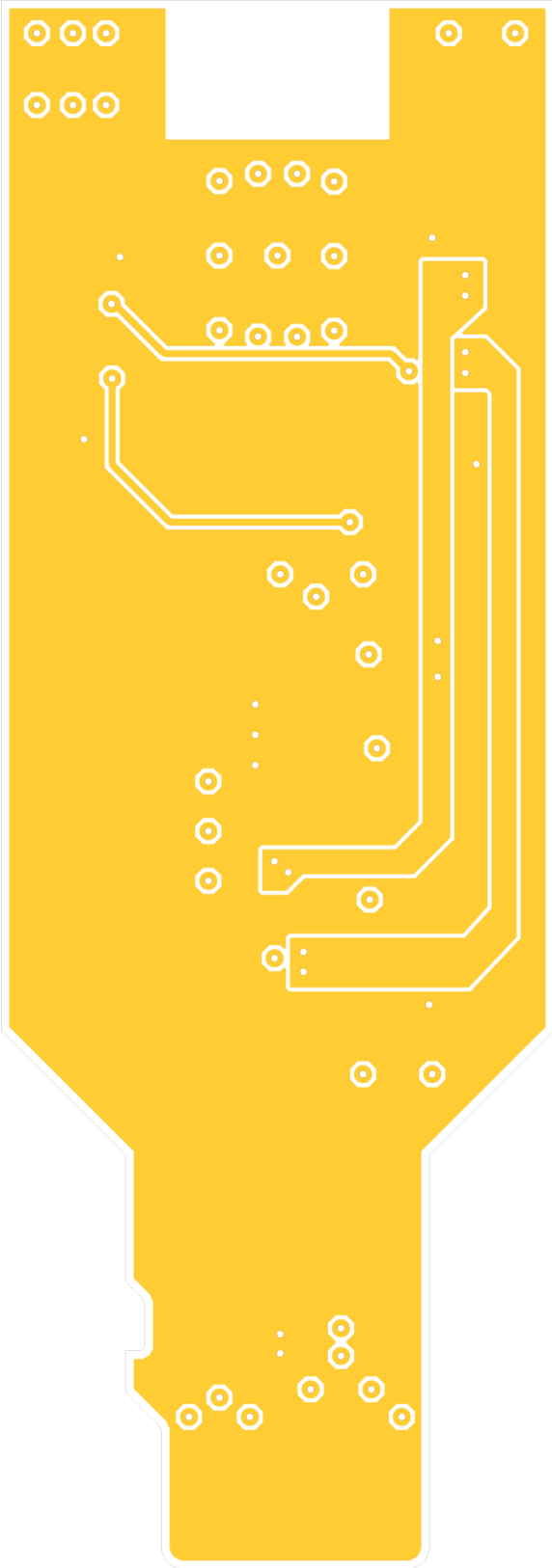

5.5.4 Bottom Layer

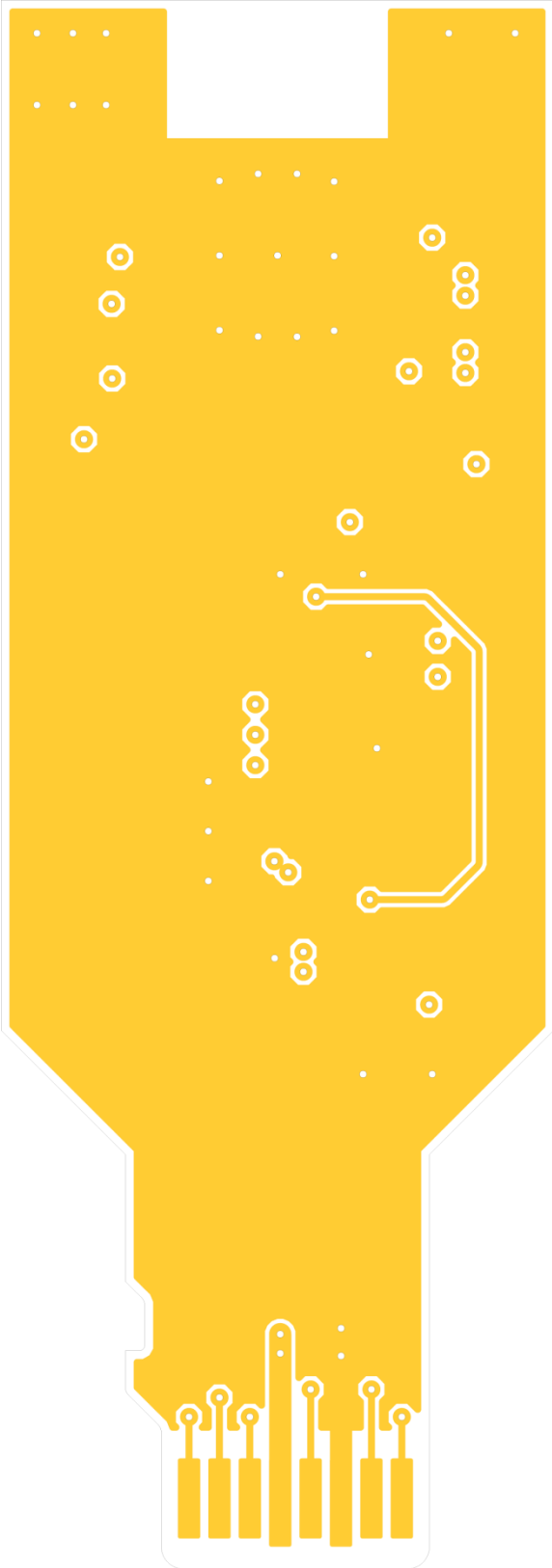

6 Cautions

6.1 Restricted Use

6.1.1 Life Support Policy

This Panasonic Industrial Devices Europe GmbH product is not designed for use in life support appliances, devices, or systems where malfunction can reasonably be expected to result in a significant personal injury to the user, or as a critical component in any life support device or system whose failure to perform can be reasonably expected to cause the failure of the life support device or system, or to affect its safety or effectiveness.

Panasonic customers using or selling these products for use in such applications do so at their own risk and agree to fully indemnify Panasonic Industrial Devices Europe GmbH for any damages resulting.

6.1.2 Restricted End Use

This Panasonic Industrial Devices Europe GmbH product is not designed for any restricted activity that supports the development, production, handling usage, maintenance, storage, inventory or proliferation of any weapons or military use.

Transfer, export, re-export, usage or reselling of this product to any destination, end-user or any end-use prohibited by the European Union, United States or any other applicable law is strictly prohibited.

7 Appendix

7.1 Ordering Information

Variants and Versions

Order Number	Brand Name	Description	MOQ ¹
ENWF9201A1EF ²	PAN9026	Wif-Fi/Bluetooth radio module IEEE 802.11 a/b/g/n BT/BLE 5.0 with a ceramic chip-antenna, US version ³	1 000
ENWF9202A1EF ²	PAN9026	Wif-Fi/Bluetooth radio module IEEE 802.11 a/b/g/n BT/BLE 5.0 with a ceramic chip-antenna, EU version ⁴	1 000
ENWF9203A1EF ²	PAN9026	Wif-Fi/Bluetooth radio module IEEE 802.11 a/b/g/n BT/BLE 5.0 with a ceramic chip-antenna, CA version ⁵	1 000
ENWF9201AZEF	PAN9026-ETU	PAN9026 SDIO Adapter with module ENWF9201A1EF	1
ENWF9201AYEF	PAN9026-KIT	PAN9026 Kit: 2x PAN9026 SDIO Adapter with module ENWF9201A1EF and 1x Case	1
ENWF9201AXEF	PAN9026-IMX	i.MX6+PAN9026 Development Kit: 1x PAN9026 MicroSD Adapter, 1x Wandboard WBIMX6U, 1x MicroSD Card, 1x Adapter cable USB-A to DC 5.5/2.5mm plug	1
ENWF9201AWEF	PAN9026-MSD	PAN9026 MicroSD Adapter with module ENWF9201A1EF	1

¹ Abbreviation for Minimum Order Quantity (MOQ). The standard MOQ for mass production is 1 000 pieces, fewer only on customer demand. Samples for evaluation can be delivered at any quantity via the distribution channels.

² Samples are available on customer demand.

³ The US version is restricted to FCC regulatory domain with blocked country code and Tx power table. The device does not support the channels 12 -13 in the 2.4 GHz band and any non-US channels. TPC, DFS, and passive scanning mechanism are set by the regulatory domain's channel table, which is stored on the OTP memory of device.

⁴ The EU version is restricted to European regulatory domain ETSI with blocked country code and Tx power table. TPC, DFS, and passive scanning mechanism are set by the regulatory domain's channel table, which is stored on the OTP memory of device.

⁵ The CA version is restricted to Canadian regulatory domain ISED with blocked country code and Tx power table. The device does not support the channels 12 -13 in the 2.4 GHz band and any non-CA channels. TPC, DFS, and passive scanning mechanism are set by the regulatory domain's channel table, which is stored on the OTP memory of device.

7.2 Contact Details

7.2.1 Contact Us

Please contact your local Panasonic Sales office for details on additional product options and services:

For Panasonic Sales assistance in the **EU**, visit

<https://eu.industrial.panasonic.com/about-us/contact-us>

Email: wireless@eu.panasonic.com

For Panasonic Sales assistance in **North America**, visit the Panasonic Sales & Support Tool to find assistance near you at

<https://na.industrial.panasonic.com/distributors>

Please visit the **Panasonic Wireless Technical Forum** to submit a question at

<https://forum.na.industrial.panasonic.com>

7.2.2 Product Information

Please refer to the Panasonic Wireless Connectivity website for further information on our products and related documents:

For complete Panasonic product details in the **EU**, visit

<http://pideu.panasonic.de/products/wireless-modules.html>

For complete Panasonic product details in **North America**, visit

<http://www.panasonic.com/rfmodules>